

**SERVOSTAR<sup>®</sup> S and SERVOSTAR<sup>®</sup> CD**  
*Installation Manual*

## Record of Manual Revisions

ISSUE NO.	DATE	DESCRIPTION OF REVISION
0	--	Preliminary issue for review
1	01/05/98	Initial release of UCB hardware
2	03/13/98	Added UCB features
3	09/18/98	Cx and UCB position capability (restructure document)
4	12/03/98	Additional position features added
5	05/01/99	Restructured SERCOS interface, CD-ROM transition
6	09/15/99	Appendix A and B added, sine encoder features, Cx10 added
7	06/30/00	Added information on Firmware upgrade
8	10/10/00	Corrected specifications, added clarification
9	02/01/01	Corrected Electrical Specs and wiring diagrams (restructure document)
10	02/28/01	Added information for Firmware upgrade
11	09/28/01	Corrected Wiring Diagrams, errors in commands, and EMI filter info
12	01/16/02	Corrected Outline Dimensions for Cx units and all wiring diagrams
13	03/27/02	Corrected Model Numbers and added Danaher information
14	06/14/02	Added Appendix C
15	07/10/02	Added Appendix D, clarified digital and sine encoder specifications
16	11/22/02	Standardized units of measure
17	12/16/02	Updated encoder phasing and added IP 30-30 information
18	02/14/03	Corrected Sx Hardware Specifications
19	04/18/03	Added extended I/O information for Series 5

## Copyright Information

© Copyright 1998 - 2003 Danaher Motion Kollmorgen - All rights reserved.

Printed in the United States of America.

## NOTICE:

Not for use or disclosure outside of Danaher Motion Kollmorgen except under written agreement. All rights are reserved. No part of this book shall be reproduced, stored in retrieval form, or transmitted by any means, electronic, mechanical, photocopying, recording, or otherwise without the written permission from the publisher. While every precaution has been taken in the preparation of the book, the publisher assumes no responsibility for errors or omissions. Neither is any liability assumed for damages resulting from the use of the information contained herein.

This document is proprietary information of Danaher Motion Kollmorgen that is furnished for customer use ONLY. No other uses are authorized without written permission of Danaher Motion Kollmorgen. Information in this document is subject to change without notice and does not represent a commitment on the part Danaher Motion Kollmorgen. Therefore, information contained in this manual may be updated from time-to-time due to product improvements, etc., and may not conform in every respect to former issues.

VGA® and PC-AT® are registered trademarks of International Business Machines Corporation

Windows®95/98 and Windows NT® are registered trademarks of Microsoft Corporation

ENDAT® is a registered trademark of Dr. Johannes Heidenhain GmbH

**GOLDLINE®**, **SILVERLINE®**, **MOTIONEERING®**, **MOTIONLINK®**,

**PLATINUM®**, and **SERVOSTAR®** are registered trademarks of Danaher Motion Kollmorgen.

## Safety Instructions

Only qualified personnel are permitted to transport, assembly, commission, and maintenance this equipment. Properly qualified personnel are persons who are familiar with the transport, assembly, installation, commissioning and operation of motors, and who have the appropriate qualifications for their jobs. The qualified personnel must know and observe the following standards and regulations:

IEC 364 resp. CENELEC HD 384 or DIN VDE 0100

IEC report 664 or DIN VDE 0110

National regulations for safety and accident prevention or VBG 4

- Read all available documentation before assembly and commissioning. Incorrect handling of products in this manual can result in injury and damage to persons and machinery. Strictly adhere to the technical information on the installation requirements.
- It is vital to ensure that all system components are connected to earth ground. Electrical safety is impossible without a low-resistance earth connection.
- The SERVOSTAR® product contains electro-statically sensitive components that can be damaged by incorrect handling. Discharge yourself before touching the product. Avoid contact with high insulating materials (artificial fabrics, plastic film, etc.). Place the product on a conductive surface.
- During operation keep all covers and cabinet doors shut. Otherwise, there are deadly hazards that could possibly cause severe damage to health or the product.
- In operation, depending on the degree of enclosure protection, the product can have bare components that are live or have hot surfaces. Control and power cables can carry a high voltage even when the motor is not rotating.
- Never pull out or plug in the product while the system is live. There is a danger of electric arcing and danger to persons and contacts.
- After powering down the product, wait at least ten minutes before touching live sections of the equipment or undoing connections (e.g., contacts, screwed connections). Capacitors can store dangerous voltages for long periods of time after power has been switched off. To be safe, measure the contact points with a meter before touching.

When these symbols are seen in this manual, be alert to the potential for personal injury. Follow the recommended precautions and safe operating practices included with the alert symbols. Safety notices in this manual provide important information. Read and be familiar with these instructions before attempting installation, operation, or maintenance. The purpose of this section is to alert users to possible safety hazards associated with this equipment and the precautions that need to be taken to reduce the risk of personal injury and damage to the equipment. Failure to observe these precautions could result in serious bodily injury, damage to the equipment, or operational difficulty.

- The safety-alert symbols are:



**Warning** Alerts users to potential physical danger or harm. Failure to follow warning notices could result in personal injury or death.



**Caution** Directs attention to general precautions, which if not followed, could result in personal injury and/or equipment damage.



**Note** Highlights information critical to your understanding or use of the product.

## Directives and Standards

The SERVOSTAR S and SERVOSTAR CD product series have been successfully tested and evaluated to meet UL/cUL 508C for both U.S. and Canadian markets. This standard describes the fulfillment by design of minimum requirements for electrically operated power conversion equipment, such as frequency converters and servo amplifiers, which is intended to eliminate the risk of fire, electric shock, or injury to persons, being caused by such equipment.

## CE Mark Conformance

Servo drives are components that are intended to be incorporated into electrical plant and machines for industrial use. When the servo drives are built into machines or plants, drives cannot be operated until the machine or plant fulfills the requirements of the EC Directive on Machines 89/392/EEC and the EC Directive on EMC (89/336/EEC). EN 60204 and EN 292 must also be observed.

In connection with the Low Voltage Directive 73/23/EEC, the harmonized standards of the EN 50178 series are applied to the amplifiers, together with EN 60439-1, EN 60146 and EN 60204.

The manufacturer of the machine or plant is responsible for ensuring that they meet the limits required by the EMC regulations. Advice on the correct installation for EMC - such as shielding, grounding, arrangement of filters, treatment of connectors and the laying out of cabling - can be found within this documentation.

Conformance with the EC Directive on EMC 89/336/EEC and the Low Voltage Directive 73/23/EEC is mandatory for the supply of servo drives within the European Community.

An authorized testing laboratory in a defined configuration with the system components has tested the servo drives. Any divergence from the configuration and installation described in this documentation means that you are responsible for the performance of new measurements to ensure that the regulatory requirements are met.

Danaher Motion Kollmorgen's SERVOSTAR S-Series and C-Series drives and systems have been successfully tested and evaluated to the limits and requirements of the EC Directive on EMC (89/336/EEC) and the EC Directive on Low Voltage (72/73/EEC). The product lines have been evaluated to EN50178 and EN60204 as a component of a machine and other relevant standards.

The EMC of a system can be identified by emissions and immunity. Emissions refer to the generation of EMI (electromagnetic interference) and immunity refers to the susceptibility levels of the equipment. Limits were derived from generic standards EN55081-2 and EN55082-2 for heavy industrial environments. The SERVOSTAR S and SERVOSTAR CD series of drives and BUS Modules have been tested for radiated emissions, conducted emissions, EFT, ESD, surge, conducted immunity, and radiated immunity. These tests have been done in accordance with EN55011, EN61000-4-2, ENV50140, IEC 1000-4-4, EN61000-4-5, and ENV50141.



***Installation of the equipment is critical in designing for system and machine electromagnetic compatibility (EMC). You must apply the installation recommendations and the CE filtering Practices when mounting and installing the drive system for CE conformance.***

## Table of Contents

<b>READ BEFORE INSTALLING</b> .....	<b>1</b>
USE AS DIRECTED .....	2
<b>UNPACKING AND INSPECTING</b> .....	<b>3</b>
BUS MODULE MODEL NUMBERS .....	3
SERVOSTAR S/CD MODEL NUMBERS .....	4
<b>MOUNTING</b> .....	<b>5</b>
HARDWARE SPECIFICATIONS .....	5
<i>SERVOSTAR Cx</i> .....	5
<i>SERVOSTAR Sx</i> .....	6
<i>BUS Module</i> .....	8
<i>Product Family Control Specifications</i> .....	9
OUTLINE DIMENSIONS.....	10
<i>Sx and PA Units</i> .....	10
Physical Dimensions .....	10
<i>Cx Units</i> .....	11
<i>PA-LM Units</i> .....	11
<b>WIRING</b> .....	<b>12</b>
ENCLOSURE .....	12
GROUNDING.....	13
BONDING .....	13
<i>Non-insulated Cable Clamp</i> .....	14
<i>Alternative Bonding Methods</i> .....	14
CE FILTERING TECHNIQUES.....	16
<i>Input Power Filtering</i> .....	16
<i>Motor Line Filtering</i> .....	18
<i>I/O Filtering</i> .....	20
<i>Cx Filter and Bonding Diagram</i> .....	21
<i>Sx Filter and Bonding Diagram</i> .....	22
SYSTEM INTERCONNECT.....	23
<i>Cx Electrical Specifications</i> .....	23
<i>Sx Electrical Specifications</i> .....	24
<i>BUS Module Electrical Specifications</i> .....	26

<i>Cx Regen Information</i> .....	28
<i>BUS Module Regen Information</i> .....	29
<i>Kit Parts and Models</i> .....	30
<b>WIRING DIAGRAMS</b> .....	31
<i>Bus Module Simplified Schematic</i> .....	31
<i>Cx Wiring Diagram</i> .....	32
<i>Sx with PA08, 14, or 28 Wiring Diagram</i> .....	33
<i>Sx with PA50, 75, or 85 Wiring Diagram</i> .....	34
<i>BUS Module – PA-LM (Multiple Sx units)</i> .....	35
<b>PIN-OUT CONNECTIONS</b> .....	36
<i>Front View</i> .....	36
<i>Top View</i> .....	37
<b>SYSTEM FEEDBACK DIAGRAM</b> .....	38
<b>FEEDBACK DEVICES</b> .....	39
<i>Resolver</i> .....	39
Specifications .....	39
Cable Lengths.....	39
Resolution and Accuracy .....	40
<i>Digital Encoder</i> .....	40
Specifications .....	41
Cable Lengths.....	41
Resolution and Accuracy .....	41
<i>Sine Encoder</i> .....	42
Specifications .....	43
Cable Lengths.....	43
Resolution and Accuracy .....	44
<b>ENCODER EQUIVALENT OUTPUT</b> .....	44
<i>Resolver Systems</i> .....	44
<i>Encoder Systems</i> .....	44
<i>Sine-encoder Systems</i> .....	45
<i>EEO Phasing</i> .....	45
Resolver Systems .....	45
Encoder and Sine-encoder Systems .....	45
<i>Recommended Manufacturers' List</i> .....	46
<b>SYSTEM COMMUNICATION</b> .....	47
<b>COMPUTER REQUIREMENTS</b> .....	47
<b>DRIVE COMMUNICATION</b> .....	48
<i>RS-232-A Connection</i> .....	48

<i>RS-485 Connection</i> .....	49
<i>Setting Drive Address</i> .....	49
SENDING/RETRIEVING SYSTEM DATA .....	50
MOTIONLINK INSTALLATION .....	51
<i>Installing on PC</i> .....	51
<i>Running the Program</i> .....	51
USING MOTIONLINK .....	51
<i>MOTIONLINK Startup Wizard</i> .....	51
<i>Main MOTIONLINK Screen</i> .....	53
<i>Terminal Mode</i> .....	55
MULTIDROP COMMUNICATION .....	56
POWER-UP SEQUENCE .....	57
ENABLING THE SYSTEM .....	57
<b>SERCOS INTERFACE SETUP .....</b>	<b>59</b>
DIP SWITCH CONFIGURATION .....	59
<i>Setting Drive Address</i> .....	59
<i>Setting Transmission Power Levels</i> .....	59
STATUS DISPLAY .....	60
CONNECTION .....	61
COMMUNICATIONS .....	61
<i>Drive Configuration</i> .....	62
<i>CP Run-up</i> .....	62
CP2 Initialization .....	63
CP3 Initialization .....	63
Operational Notes .....	63
Equation Notes .....	64
<b>SYSTEM OPERATION .....</b>	<b>65</b>
OPERATIONAL MODES .....	66
SYSTEM I/O .....	66
<i>Analog Input (ANIN)</i> .....	67
<i>Remote Enable Input (REMOTE)</i> .....	68
<i>Configurable Inputs (IN1, IN2, IN3)</i> .....	68
<i>Configurable Outputs (ANOUT, O1)</i> .....	68
<i>Fault Output Relay (RELAY, RELAYMODE)</i> .....	69
<i>Motor Thermostat Input (THERM, THERMODE)</i> .....	69
CONTROL LOOPS .....	69
<i>Core Processors</i> .....	70

<i>Servo Loop Description</i> .....	70
Current Loop .....	70
Commutation Loop .....	71
Velocity Loop.....	71
Position Loop .....	72
<i>Torque Loop Operation</i> .....	73
Serial Torque.....	73
Analog Torque .....	74
<i>Current Sampling</i> .....	75
FOLDBACK.....	76
<i>Drive FoldBack</i> .....	76
<i>Motor FoldBack</i> .....	76
<b>SYSTEM DESCRIPTION .....</b>	<b>77</b>
PRODUCT FEATURES.....	77
<i>Current/Torque Control</i> .....	77
<i>Velocity Control</i> .....	78
<i>Position Control</i> .....	78
<i>Profile Ramping Control</i> .....	79
<i>Motor Controllability</i> .....	80
<i>Feedback Devices</i> .....	80
Resolvers.....	80
Encoders.....	81
Sine Encoders.....	81
<i>System Communications</i> .....	81
<i>MOTIONLINK Software Environment</i> .....	82
<i>Monitoring and Troubleshooting Tools</i> .....	83
<i>Fault and Safety Detection</i> .....	83
<i>General</i> .....	84
BUS MODULE.....	85
<i>Features</i> .....	85
<b>TROUBLESHOOTING .....</b>	<b>87</b>
TROUBLESHOOTING TOOLS .....	87
ERROR CODES.....	88
<i>FATAL FAULT ERROR CODES</i> .....	89
<i>NON-FATAL ERROR CODES</i> .....	90
<i>NO MESSAGE FAULTS</i> .....	92
FAULT MONITORING SYSTEM .....	93



FIRMWARE UPGRADES .....	96
<b>APPENDIX A .....</b>	<b>97</b>
MOTOR PINOUTS .....	97
<i>Motor Power Connections</i> .....	97
<i>SR/CR RESOLVER Connection</i> .....	98
<i>SE/CE Encoder Connection</i> .....	99
PLATINUM XT MOTOR CONNECTION .....	101
<i>System Connection Diagram</i> .....	102
<b>APPENDIX B .....</b>	<b>103</b>
PROGRAMMABLE POSITIONING .....	103
<i>Installation</i> .....	103
<b>APPENDIX C .....</b>	<b>107</b>
DIGITAL INCREMENTAL ENCODER TYPES .....	107
<i>Encoder Basics: A Review</i> .....	107
<i>SERVOSTAR Encoder Types</i> .....	110
MENCTYPE 0 .....	113
MENCTYPE 1 .....	113
MENCTYPE 2 .....	114
MENCTYPE 3 .....	114
MENCTYPE 4 .....	115
MENCTYPE 5 .....	115
MENCTYPE 6 .....	115
<i>Commutation Accuracy</i> .....	116
<i>Physical Encoder Alignment</i> .....	116
<i>MECNOFF</i> .....	117
<i>System Phasing</i> .....	118
<i>Troubleshooting</i> .....	119
Line Drivers, Receivers, and Terminations .....	119
<i>Design Considerations</i> .....	120
<i>Reference Variables</i> .....	120
<i>Example</i> .....	121
<b>APPENDIX D .....</b>	<b>123</b>
RESISTIVE REGENERATION SIZING .....	123
<i>Energy Calculations</i> .....	124
<i>Regeneration Calculations</i> .....	124
Determining Resistance Value .....	125

Determining Dissipated Power.....	125
<b>APPENDIX E .....</b>	<b>127</b>
SERIES 5 UCB2 DIGITAL CONTROL BOARD .....	127
PART NUMBER.....	127
SUMMARY OF NEW FEATURES .....	128
DIFFERENCES FROM PREVIOUS MODELS.....	128
ENCODER SIMULATION.....	128
ENCODER INITIALIZATION.....	128
<i>The Process</i> .....	129
SINE/COSINE CALIBRATION .....	130
<i>The Process</i> .....	130
<i>Wiring Diagram</i> .....	131
<i>Top View</i> .....	132
<i>Connector Pin-Out</i> .....	132
<i>Sine Encoder Feedback</i> .....	133
<i>Resolver Feedback</i> .....	134
SOFTWARE RESOLVER INTERFACE.....	135
<i>The Process</i> .....	135
EXTENDED I/O.....	135

## READ BEFORE INSTALLING

These installation steps are designed to lead you through the proper installation and setup of a SERVOSTAR<sup>®</sup> S or SERVOSTAR<sup>®</sup> CD system. They were developed with the assumption that you have a fundamental understanding of basic electronics, computers, mechanics, and proper safety practices. However, you do not have to be an expert in motion control to install and operate the drive system. It is recommended that you read the entire manual completely before attempting installation or operation.



***High voltage can present dangerous and hazardous conditions if not performed by a qualified electrician. Be certain to follow all national and local codes during installation. Follow all safety precautions outlined in the accompanying CD-ROM documentation.***

1. Open the box(es) and remove all the contents. Check to ensure there is no visible damage to any of the equipment.
2. Mount the SERVOSTAR S and SERVOSTAR CD to the back panel. Refer to the appropriate Outline Dimensions in this manual. ***Metal-to-metal contact is important for electrical noise control!***
3. Wire the SERVOSTAR S and SERVOSTAR CD according to the appropriate System Wiring Diagram.
4. Connect solid earth ground to frames of all components.
5. Wire the main power (115/230 VAC).
  - A. For S-Series product: Wire the logic and DC Bus power from power supply to drive modules.
  - B. For CDxx260 and CDxx261 product wire the 24 volt supply to the connector at the top of the drive.
6. Wire user I/O at connector C3: At a minimum, 24 volts must be brought in to the enable circuit. Be certain that connector C3 is inserted correctly.
7. Wire the motor and feedback. Refer to the Feedback Wiring Diagram for additional information.
8. Wire Regen Resistor kit, if applicable.
9. Verify that all wiring is correct.
10. Verify that earth grounds are connected.
11. Verify all electrical and safety codes are met.
12. Connect the serial cable to connector C2 and PC.  
Refer to the appropriate System Wiring Diagram.

13. Install **MOTIONLINK** on the PC.



*Startup processes can cause motor motion. Be certain that all applicable safety precautions are taken to ensure that no harm to personal or machine can occur.*

14. Using the Startup Wizard in **MOTIONLINK**:

- A. Configure the **SERVOSTAR S** or **SERVOSTAR CD** for your particular motor, if this was not done at the factory. Refer to the **MOTIONLINK** Startup Wizard.
- B. Enable the system.

## Use As Directed

---

The restrictions for proper use of a **SERVOSTAR S** or **SERVOSTAR CD** system are:

- These amplifiers are components that are built into electrical equipment or machines and can only be commissioned as integral components of such equipment.
- The servo amplifiers are to be used only on earthed, three-phase industrial mains supply networks (TN-system, TT-system with earthed neutral point).
- The servo amplifiers must not be operated on power supply networks without an earth or with an asymmetrical earth.
- If the servo amplifiers are used in residential areas, or in business or commercial premises, you must implement additional filtering measures.
- The servo amplifiers are only intended to drive specific brushless synchronous servomotors from Danaher Motion Kollmorgen, with closed-loop control of torque, speed, and position. The rated voltage of the motors must be at least as high as the DC-link voltage of the servo amplifier.
- The servo amplifiers may only be operated in a closed switch gear cabinet, taking into account the ambient conditions defined in the environmental specifications.
- Danaher Motion Kollmorgen guarantees the conformance of the servo amplifiers with the standards for industrial areas stated in the front of this manual only if Danaher Motion Kollmorgen delivers the components (motors, cables, amplifiers etc).

## UNPACKING AND INSPECTING



*Electronic components in this amplifier are design hardened to reduce static sensitivity. However, proper procedures should be used when handling.*



*Remove all packing material and equipment from the shipping container. Be aware that some connector kits and other equipment pieces may be quite small and can be accidentally discarded if care is not observed when unpacking the equipment. Do not dispose of shipping materials until the packing list has been checked.*



*Upon receipt of the equipment, inspect components to ensure that no damage has occurred in shipment. If damage is detected, notify the carrier immediately. Check all shipping material for connector kits, manuals, diskettes, and other small pieces of equipment.*

## Bus Module Model Numbers

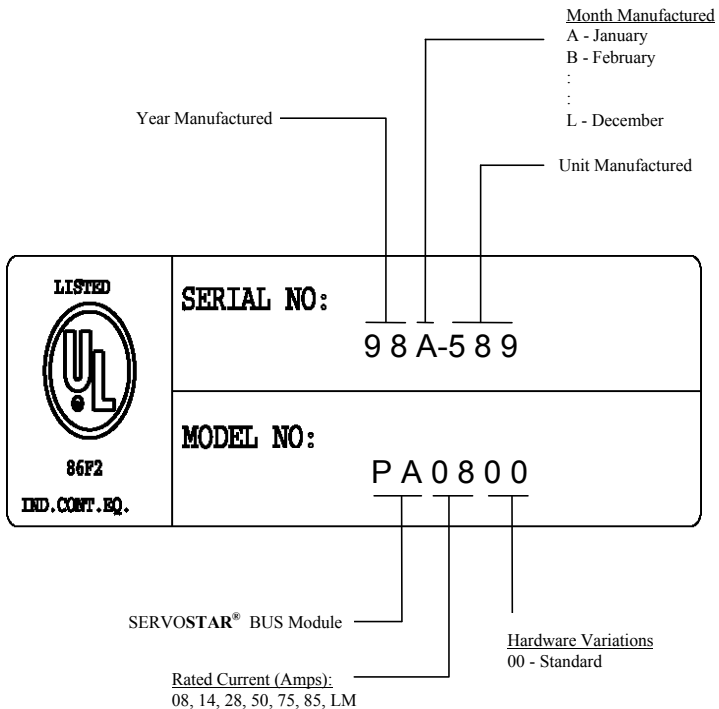

# SERVOSTAR S/CD Model Numbers

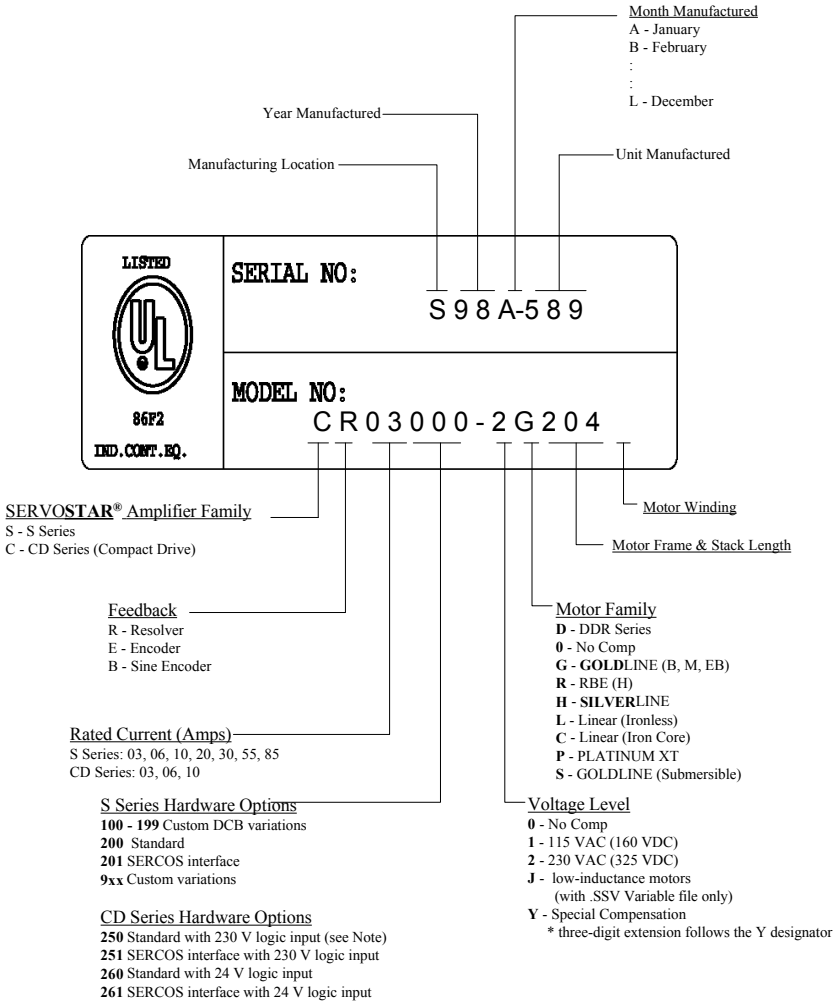

**Note: 250 replaces previous standard option (200) originally intended for single phase 3 and 6 amp units.**

## MOUNTING

For proper ventilation, the SERVOSTAR S or the SERVOSTAR CD and BUS Module units should be mounted vertically. No horizontal distance between the drive and BUS Module is required. In systems using more than two SERVOSTAR units per BUS Module, divide the drives equally on either side of the BUS Module. These products are designed for mounting in an electrical enclosure to protect them from physical and environmental damage.

## Hardware Specifications

### *SERVOSTAR Cx*

Amplifier Model		Cx03	Cx06	Cx10
<b>Unit Weight</b>	Lbs./Kgs.	3.56/1.61	4.9/2.22	5.94/2.69
<b>Mounting Hardware</b>	English (Metric)	10-32 (M4)		
	Applied Torque	20 lb-in. (2.26 Nm.)		
<b>Connection Hardware</b>	Line Screw Size/Torque	M3.5/12 lb-in. (1.35 N-m.)		
	BUS Screw Size/Torque			
	Motor Screw Size/Torque			
	Ground Screw Size/Torque			
<b>Wire Size (AWG#)</b>	Control Logic (AWG/ mm <sup>2</sup> )	16 / 1.5		
	Motor Line (AWG/ mm <sup>2</sup> )	14 / 2.5		
	Main Input (AWG/ mm <sup>2</sup> )	14 / 2.5	12 / 4	
	Configurable I/O wire gauge	22-18 AWG (0.3-0.75 mm <sup>2</sup> ) Ferrules recommended: 18 AWG Type H0 - 75/14 Weidmuller 4629.0 or equivalent 20 AWG Type H0 - 5/14 Weidmuller 6907.0 or equivalent 22 AWG Type H0 - 34/12 Weidmuller 902577 or equivalent		
	Spade Terminals	16/14 AWG (1.5 mm <sup>2</sup> ): Hollingsworth XSS0954S OR SS20947SF or equivalent 12/10 AWG (4-6 mm <sup>2</sup> ): Hollingsworth XSS20836 OR SS20832F or equivalent		
<b>Clearance Distance</b>	Side-to-Side	0.5in (12.7mm)		
	Top/Bottom	2.5in (63.5mm)		
<b>Mating Connector Hardware</b>	CK100 Kit	Includes: C1, C2, C4, C7 (plus 2 ft./0.69 m. of stranded bus ribbon), C8		
	C3	Danaher Motion Kollmorgen #: A-93899-013 Vendor Info: Weidmuller BL3.5/13 Cat.No. 161574		
	C5	Danaher Motion Kollmorgen #: A-81014-004 Vendor Info: PCD ELFP04110		
	Connector Screw Torque	2.25 lb-in. (0.25 m.)		
	24 V Logic (optional)	Danaher Motion Kollmorgen #: A-81014-002 Vendor Info: PCD ELFP02210 (or equiv.)		

**SERVOSTAR Sx**

Amplifier Model		Sx03	Sx06	Sx10	Sx20
<b>Unit Weight</b>	lbs / Kgs	6.3 / 2.85		7.3 / 3.3	9.9 / 4.5
<b>Mounting Hardware</b>	English (Metric)	10-32 (M4)			
	Applied Torque	20 lb-in (2.26 N-m.)			
<b>Connection Hardware</b>	BUS Screw Size/Torque	6-32 / 12lb-in (1.35 N-m.)			
	Motor Screw Size/Torque	6-32 / 12 lb-in (1.35 N-m.)			
	Ground Screw Size/Torque	M4 / 12 lb-in (1.35 N-m)			
<b>Wire Size (AWG#)</b>	Control Logic (AWG/ mm <sup>2</sup> )	18/0.75			
	Motor Line (AWG/ mm <sup>2</sup> )	14/2.5		10/4	
	Configurable I/O wire gauge	22-18 AWG (0.3 - 0.75mm <sup>2</sup> ) Ferrules recommended: 18 AWG Type H0 - 75/14 Weidmuller 4629.0 or equivalent 20 AWG Type H0 - 5/14 Weidmuller 6907.0 or equivalent 22 AWG Type H0 - 34/12 Weidmuller 902577 or equivalent			
	Spade Terminals	16/14 AWG (1.5 mm <sup>2</sup> ) Hollingsworth XSS0954S OR SS20947SF or equivalent 12/10 AWG (4-6 mm <sup>2</sup> ) Hollingsworth XSS20836 OR SS20832F or equivalent			
<b>Clearance Distance</b>	Side-to-Side	No Distance Required			
	Top/Bottom	2.5 in (63.5 mm.)			
<b>Mating Connector Hardware</b>	CK100 Kit	Includes: C1, C2, C4, C7 (plus 2ft / 0.25m of stranded bus ribbon), C8			
	C3	Danaher Motion Kollmorgen #: A-93899-013 Vendor Info: Weidmuller BL3.5/13 Cat.No. 161574			
	C5	Danaher Motion Kollmorgen #: A-81014-004 Vendor Info: PCD ELFP04110			
	Connector Screw Torque	2.25 lb-in.			



Amplifier Model		Sx30	Sx55	Sx85
<b>Unit Weight</b>	lbs / Kgs	11.5 / 5.2	14.3 / 6.5	19.7 / 9.0
<b>Mounting Hardware</b>	English (Metric)	10-32 (M4)		
	Applied Torque	20 lb-in (2.26 N-m.)		
<b>Connection Hardware</b>	BUS Screw Size/Torque	6-32 / 12lb-in (1.35 N-m.)		
	Motor Screw Size/Torque	10-32 / 20 lb-in (2.26 N-m)	M5/20 lb-in. Box Lug	
	Ground Screw Size/Torque	M4 / 20 lb-in (2.26 N-m)	M5/20 lb-in. (2.26 N-m)	
<b>Wire Size (AWG#)</b>	Control Logic (AWG/mm <sup>2</sup> )	18/0.75		
	Motor Line (AWG/mm <sup>2</sup> )	8/10	4/25	2/35
	Configurable I/O wire gauge	22-18 AWG (0.3 - 0.75mm <sup>2</sup> ) Ferrules recommended: 18 AWG Type H0 - 75/14 Weidmuller 4629.0 or equivalent 20 AWG Type H0 - 5/14 Weidmuller 6907.0 or equivalent 22 AWG Type H0 - 34/12 Weidmuller 902577 or equivalent		
	Spade Terminals	16/14 AWG (1.5 mm <sup>2</sup> ): Hollingsworth XSS0954S OR SS20947SF or equivalent 12/10 AWG (4-6 mm <sup>2</sup> ): Hollingsworth XSS20836 OR SS20832F or equivalent		
<b>Clearance Distance</b>	Side-to-Side	No Distance Required		
	Top/Bottom	2.5 in (63.5 mm)		
<b>Mating Connector Hardware</b>	CK100 Kit	Includes: C1, C2, C4, C7 (plus 2 ft/ 0.25 m of stranded bus ribbon), C8		
	C3	Danaher Motion Kollmorgen #: A-93899-013 Vendor Info: Weidmuller BL3.5/13 Cat.No. 161574		
	C5	Danaher Motion Kollmorgen #: A-81014-004 Vendor Info: PCD ELFP04110		
	Connector Screw Torque	2.25 lb-in.		

**BUS Module**

BUS Module Model		PA-LM	PA08	PA14	PA28	PA50	PA75	PA85
<b>Unit Weight</b>	Lb./Kg.	2.5/1.32	4.74/2.16	8.18/3.72	14.32/6.51	14.52/6.6	15/6.8	
<b>Mounting Hardware</b>	English (Metric)	10-32 (M4)						
	Applied Torque	20 lb-in. (2.26 N-m)						
<b>Connection Hardware</b>	Line Screw Size/Torque		6-32/ 12 lb-in (1.35 N-m)	10-32/ 12 lb-in. (1.35 N-m)	M5/ 20 lb-in. 2.26 N-m)		Box Lug	
	BUS Screw Size/Torque						M5/ 20 lb-in. (2.26 N-m)	
	Ground Screw Size/Torque	M4/12 lb-in. (1.35 N-m)						
	Control Logic	18/0.75						
<b>Wire Size AWG#/mm<sup>2</sup></b>	Main Input (gauge based on 90° C wire)		14/2.5	12/4	8/6	6/16	2/35	2/35
	BUS bar wire		14/2.5	12/4	8/6	6/16	2/35	2/35
<b>Clearance Distance</b>	Spade Terminals	16/14 AWG (1.5 mm <sup>2</sup> ): Hollingsworth XSS0954S OR SS20947SF or equivalent 12/10 AWG (4-6 mm <sup>2</sup> ): Hollingsworth XSS20836 OR SS20832F or equivalent						
	Side-to-Side	No Distance Required						
<b>Mating Connectors</b>	Top/Bottom	63.5 mm. (2.5 in.)						
	CK100 Kit	Includes: C1, C2, C4, C7 (plus 2' of stranded bus ribbon), C8						
<b>Mating Connectors</b>	C6	Danaher Motion Kollmorgen #: A-81014-002 Vendor Info: PCD ELFP02110						
	C7	Danaher Motion Kollmorgen #: A-81014-004 Vendor Info: PCD ELFP04110						
	C8	Danaher Motion Kollmorgen #: A-81014-003 Vendor Info: PCD ELFP03110						
	Connector Screw Torque	2.25 lb-in. (0.25 N-m)						

## Product Family Control Specifications

Product Model		Control Specifications
Current Loop	Update Rate	62.5 $\mu$ s (16 kHz)
	Bandwidth	<2000 Hz
Commutation Loop	Update Rate	62.5 $\mu$ s (16 kHz)
	Max. Commutation Freq.	400Hz
	Output Waveform	Sinusoidal
Velocity Loop	Update Rate	250 $\mu$ s (4k Hz)
	Bandwidth	<400 Hz
	Speed Command Resolution	Serial: 1 rpm / Analog: (1/6554) * VMAX
	Long-term Speed Regulation	0.01% ( $\mu$ s clock tolerance)
Position Loop	Update Rate	500 $\mu$ s (2 kHz)
<b>I/O Connector (C3 by pinout)</b>		
Analog Input (2, 3)	Absolute Maximum Voltage	13 V differential
	Input Resolution	14 Bit/1.2
	Sensitivity	1.53 mV min
	Voltage Range	-10V to +10V = -120% Motor rated speed to +120% Motor rated speed (Adjustable Vscale parameter)
	Input Impedance/CMR	> 10 K $\Omega$ /50 dB
	Long-term Drift	100 ppm (0.075%/°C)
Fault Output Relay (5, 6)	Max Capacity	1 A at 24 VDC
Remote Enable (7, 8) Configurable Inputs(7, 9, 10, 11)	Bandwidth	2.5 kHz (Opto-isolated)
	Input Voltage Range	12 V to 24 V Nominal (bi-directional)
	Min. On/Max. Off	10 V/1 V
	Current Demand per Input	20 mA (max)
Configurable Digital Output (7, 12)	Output Voltage (max.)	0 V to 48 V Nominal – bi-directional (Open Collector)
	(Min. On)	1 V
	Max. Output Current	60 mA
Configurable Analog Output (13, 4)	Max. Output Current	1 mA (1 K $\Omega$ internal series resistance)
	Sensitivity / Resolution	4.9 mV/12 bit
	Voltage Range	-10 V to +10V
<b>Encoder Equivalent Output (C4 by pinout)</b>		
A/B/I & Complements (1, 2, 4, 5, 7, 8)	Output Voltage (high level) at 25°C	2.5 V min. at 20 mA Differential
	RS 485 Line Drive Type	DS26C31TM
<b>Remote Encoder Input (C8 by pinout)</b>		
A/B/I & Complements (1, 2, 4, 5, 7, 8)	Input Voltage at 25°C	$\pm$ 5 V Differential
	Input Sensitivity	$\pm$ 0.2V
	Input Impedance	100 $\Omega$
	RS 485 Line Receiver Type	SN75173

See the section on Position Loop in Section 6 for features using this input.

**Note:** A flyback diode is necessary for inductive loads connected across the O1 output.

# Outline Dimensions

## *Sx and PA Units*

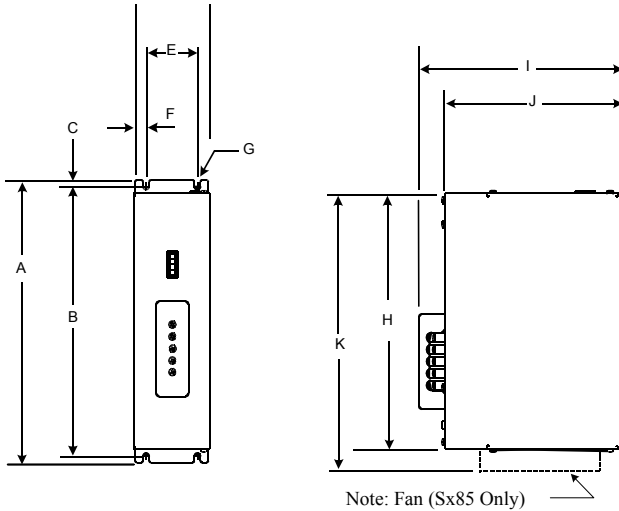

## PHYSICAL DIMENSIONS

Inches

Product	A	B	C	D	E	F	G	H	I	J	K
Sx03/06	10.39	9.921	0.24	2.91	1.969	0.49	0.228	9.37	7.95	6.89	X
Sx10	10.39	9.921	0.24	3.54	1.969	0.79	0.228	9.37	7.95	6.89	X
Sx20	10.39	9.921	0.24	4.67	1.969	1.35	0.228	9.37	7.95	6.89	X
Sx30	10.39	9.921	0.24	5.59	2.953	1.32	0.228	9.37	8.27	6.89	X
Sx55	11.89	11.10	0.24	6.30	4.00	1.13	0.228	10.39	8.30	7.00	X
Sx85	11.87	11.07	0.40	7.27	4.00	1.64	0.228	10.37	8.61	6.91	12.63
PA08	10.39	9.921	0.24	2.50	1.969	0.24	0.228	9.37	7.95	6.89	X
PA14/28	10.39	9.921	0.24	4.90	1.969	1.46	0.228	9.37	7.95	6.89	X
PA50/75/85	11.89	11.10	0.24	6.53	4.000	1.22	0.228	10.39	8.35	7.01	X

Millimeters

Product	A	B	C	D	E	F	G	H	I	J	K
Sx03/06	264	252.00	6.0	75	50.00	12.5	5.80	238	202	175	X
Sx10	264	252.00	6.0	90	50.00	20	5.80	238	202	175	X
Sx20	264	252.00	6.0	118.6	50.00	34.3	5.80	238	202	175	X
Sx30	264	252.00	6.0	142	75.00	33.5	5.80	238	210	175	X
Sx55	302	282.00	6.0	160	101.6	33.0	5.80	264	211	178	X
Sx85	301.	281.20	10.2	184.7	101.6	41.6	5.80	263.4	218.8	175.	320.
PA08	264	252.00	6.0	63.5	50.00	6.75	5.80	238	202	175	X
PA14/28	264	252.00	6.0	124.4	50.00	37.2	5.80	238	202	175	X
PA50/75/85	302	282.00	10	166	101.6	31	5.80	264	202	178	X

### Cx Units

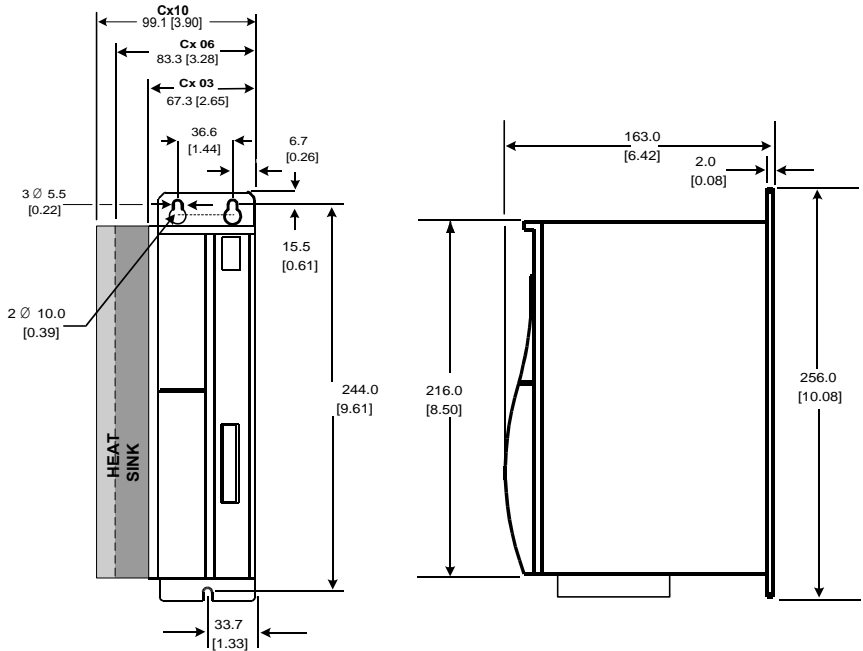

### PA-LM Units

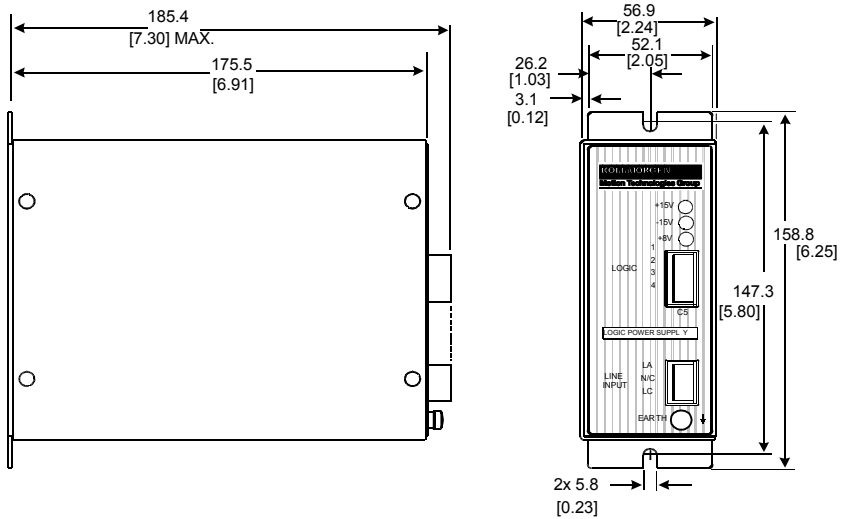

## WIRING

The environment that any electronic control system ‘lives’ in can effect its operation. Danaher Motion Kollmorgen recommends that the **SERVOSTAR** system be operated and stored under the environmental conditions stated in the product specification tables. The system may be operated in higher temperature ambient conditions with a derating applied. Please check with the factory for derating information.

Attention to proper installation and field wiring are of prime importance to ensure long-term and trouble-free operation. Users should familiarize themselves with and follow the installation and wiring instructions listed in this section. In addition to these practices, some localities and industries may require applicable electrical and safety codes, laws, and standards.

Particular care should be used when layout of an enclosure is designed. Efforts to separate power wires from small signal wires should be taken. The following guidelines highlight some important wiring practices to implement:

- Control and signal cables must be separated from power and motor cables. Distance of 20 cm (8 in.) is sufficient in most cases.
- Control and signal cables must be shielded to reduce the effects of radiated interference.
- Where control cables must cross power or motor cables, they should cross at a 90° angle, if possible. This reduces the field coupling effect.

## Enclosure

The Danaher Motion Kollmorgen **SERVOSTAR** series of electronic system components are designed for panel assembly. This panel assembly should then be mounted in a metallic enclosure. Enclosures are supplied by the manufacturers of the final product and must meet the environmental IP rating of the end product. To ensure proper grounding (and to optimize EMC), the enclosure should have continuous ground continuity maintained between all metal panels. This ground continuity is intended to be both a safety ground and a high frequency ground. The units should be mounted on a back plane, which is installed into the enclosure. Ideally, the back plane should be an unpainted metallic surface to optimize electrical bonding of the frame and provide the lowest possible impedance path to earth ground. These enclosures also provide added safety.

---

## Grounding

---

System grounding is essential for proper performance of the drive system. A ground bus bar may be used as a single point ground for the system. Safety grounding should be provided to all pieces of the system from a "star point." In addition to the safety grounding, a high frequency ground must be provided that connects the back panel to the enclosure and, ultimately, to earth ground. The objective is to provide an extremely low impedance path between the filters, drives, power supplies, and earth ground. This high frequency ground is accomplished with the use of a flat braid or copper bus bar. It is important not to rely on a standard wire for the high frequency ground. In general, a wire has an inductance of 8nH-per-inch, regardless of diameter. At higher frequencies, this unwanted inductance between grounds equates to limited filter performance. When connecting high frequency grounds, use the shortest braid possible.

---

## Bonding

---

The proper bonding of shielded cables is imperative for minimizing noise emissions and increasing immunity levels of the drive system. Its effect is to reduce the impedance between the cable shield and the back panel. Danaher Motion Kollmorgen recommends that all shielded cables be bonded to the back panel.

Power input wiring does not require shielding (screening) if the power is fed to the cabinet (enclosure) via metallized conduit. If the metallized conduit is used with proper high frequency grounds, bonding technology, and recommended wire routing, then power input wire shielding has no affect. In the event that metallized conduit is not implemented into the system, shielded cable is required on the power input wires and proper bonding technologies should be implemented.

The motor and feedback cables should have the shield exposed as close to the drive as possible. This exposed shield is bonded to the back panel using one of the two following methods.

## *Non-insulated Cable Clamp*

The following figures shows how cable bonding is implemented using non-insulated metallic cable clamps.

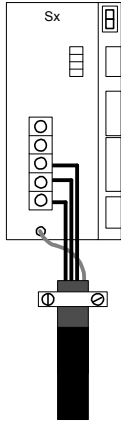

*Sx Drive Clamp*

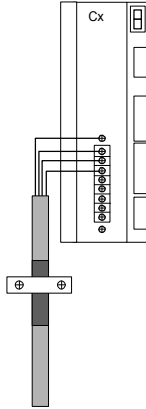

*Cx Drive Clamp*

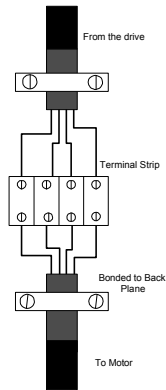

*Terminal Clamp*

## *Alternative Bonding Methods*

Another option is to use cable bonding clamps offered by Phoenix Contact (and others). When using the Phoenix Contact parts, make sure that a low impedance (high frequency) ground is connected from the ground bus bar to the back panel. This can be done with a flat braid or a copper bus bar. The SK parts from Phoenix (SK8, SK14, & SK20) slide onto the bus bar. The cable (with exposed shield) is inserted through the SK piece and the thumbscrew on top of the SK piece is used to tighten the connection between the cable shield and the bus bar.

Phoenix Contact Part #	Description	Cable Diameter Range
3025163 Type SK8	Shielded terminal block - for placing the shield on bus bars.	SK8 up to 8mm or 0.315 in
3025176 TypeSK14	Shielded terminal block - for placing the shield on bus bars.	SK14 8mm to 14mm or 0.551 in
3025189 Type SK20	Shielded terminal block - for placing the shield on bus bars.	SK20 14mm to 20mm or 0.787 in
0404428 Type AB/SS	Support for bus bar. 2 needed to mount ground bus.	N/A
0402174 Type NLS-CU 3/10	Bus bar material - 10mm x 3mm copper at varying lengths.	N/A



The next two figures represent a side and top view of the SK device that clamps down on the shield of the cable. The Phoenix SK device is excellent for providing a low impedance path between cable shield and the back panel.

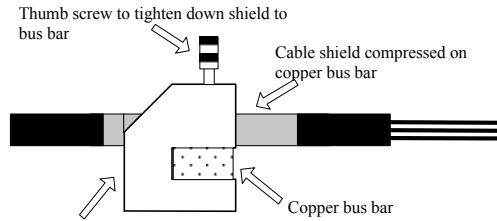

↳(8, 14, 20, - Shielded terminal block

*Phoenix Contact - Side View*

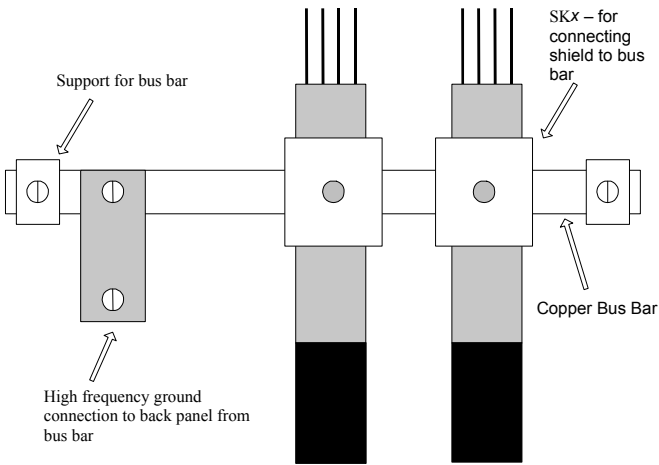

*Phoenix Contact -Top View*

---

## CE Filtering Techniques

---

The SERVOSTAR drive system (BUS Module, drive, motor) meets the CE Mark standards stated in the front of this manual. It is imperative for you to apply proper bonding and grounding techniques, described earlier in this section, when incorporating EMC noise filtering components for the purpose of meeting this standard.

Noise currents often occur in two types. The first is conducted emissions that are passed through ground loops. The quality of the system grounding scheme inversely determines the noise amplitudes in the lines. These conducted emissions are of a common-mode nature from line to neutral (or ground). The second is radiated high-frequency emissions usually capacitively coupled from line-to-line and are differential in nature.

To properly mount the filters, the enclosure should have an unpainted metallic surface. This allows for more surface area to be in contact with the filter housing and provides a lower impedance path between this housing and the back plane. The back panel, in turn, has a high frequency ground strap connection to the enclosure frame or earth ground.

### *Input Power Filtering*

The Danaher Motion Kollmorgen SERVOSTAR S and SERVOSTAR CD electronic system components require EMI filtering in the input power leads to meet the conducted emission requirements for the industrial environment. This filtering blocks conducted-type emissions from exiting onto the power lines and provides a barrier for EMI on the power lines.

Care must be taken to adequately size the system. The type of filter is based on the voltage and current rating of the system and whether the incoming line is single or three-phase. One input line filter is used for multi-axis control applications. These filters are mounted as close to the incoming power as possible so noise is not capacitively coupled into other signal leads and cables. Similarly, care should be taken when routing wires from the load side of the filter to the BUS Module. These lines may be noisy and should be separated from other sensitive cabling to avoid unwanted coupling of noise. Several manufacturers of these filters are listed below. They should be able to recommend the best filter design for most typical motor control applications. Danaher Motion Kollmorgen has also provided specific filters recommendations that adequately attenuate the conducted noise to levels well below the CE limits. The recommendations are:

- Filter should be mounted on the same panel as the drive and BUS Module.
- Filter should be mounted as close as possible to incoming cabinet power.

- Filter should be mounted as close as possible to BUS Module. If separation exceeds 30cm. (1 ft.), flat cable (braid) is used for the high frequency connection between filter and BUS Module.
- When mounting the filter to the panel, remove any paint or material covering. Use an unpainted metallic back panel, if possible.
- Filters are provided with an earth connection. All ground connections are tied to ground.
- Filters can produce high leakage currents. ***Filters must be earthed before connecting the supply!***
- Filters should not be touched for a period of 10 seconds after removing the supply.

Recommended Line Filters		
BUS Module Model #	Recommended EMI Line Filter	Danaher Motion Kollmorgen Part #
PA08 (Single phase)	Filter Concepts SF10	n/a
PA08 (3 phase)	Schaffner FN258-30/07	A-96776-003
PA28	Schaffner FN258-30/07	A-96776-003
PA50	Schaffner FN258-55/07	A-96776-005
PA75	Schaffner FN258-75/34	A-96777-001
PA85	Schaffner FN258-100/35	A-96777-002
PALM	Corcom F7202A	A-97181
PA14 (single phase)	Filter Concepts SF15	n/a
PA14 (3 phase)	Schaffner FN258-30/07	A-96776-003
Cx03	Filter Concepts SF7	n/a
	Schaffner FN258-7/07	A-96776-001
Cx06	Filter Concepts SF15	n/a
	Schaffner FN258-16/07	A-96776-002
Cx10	Schaffner FN258-16/07	A-96776-002



***The filters called out in the table above are used on a one-to-one correspondence with the drive. If drives are paralled off one filter, it needs to be sized. Drives can be ganged off one EMI filter as shown in the Filter and Bonding Diagrams.***

## Motor Line Filtering

Motor filtering may not be necessary for CE compliance of SERVOSTAR systems. However, this additional filtering increases the reliability of the system. Poor non-metallic enclosure surfaces and lengthy, unbonded (or unshielded) motor cables that couple noise line-to-line (differential) are just some of the factors that lead to the necessity of motor lead filtering.

Motor lead noise may be either common-mode or differential. The common-mode conducted currents occur between each motor lead and ground (line-to-neutral). Differential radiated currents exist from one motor lead to another (line-to-line). The filtering of the lines feeding the motor provide additional attenuation of noise currents that enter surrounding cables and equipment I/O ports in close proximity.

Differential mode currents commonly occur with lengthy motor cables. As the cable length increases, so does its capacitance and its ability to couple noise from line-to-line. While every final system is different and every application of the product causes a slightly different emission profile, it may become necessary to use differential mode chokes to provide additional noise attenuation to minimize the radiated emissions. The use of a ferrite core (placed at the drive end) on each motor lead (shown in the diagram below), attenuates differential mode noise and lower frequency (30-60 MHz) broadband emissions to within specifications. Danaher Motion Kollmorgen recommends a Fair-Rite P/N 2643665702 (or equivalent) ferrite core. You should wrap each motor lead through the core several times, as shown in the next figure.



***Never wrap a ground lead through a core.***

Differential Mode Filtering

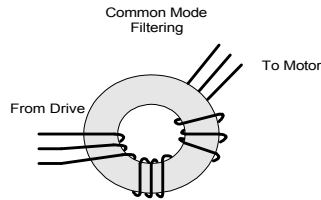
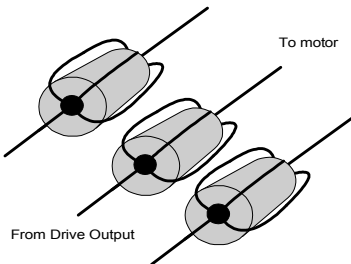

Common mode currents commonly occur from noise spikes created by the PWM switching frequency of the drive. The use of a ferrite or iron-powder core toroid places common mode impedance in the line between the motor and the drive. The use of a common mode choke on the motor leads increases signal integrity of encoder outputs and associated I/O signals. The following is a list of toroidal and ferrite cores used to make common mode chokes:

Manufacturer	Manufacturer's Part #	Size
Micrometals	T400-26D	OD 4 in (102 mm), ID 2.25 in. (57.2 mm.) HT 1.3 in (33 mm.)
Micrometals	ST102-267	OD 1.025 in(26 mm) ID 0.6 in. (15.2 mm.) HT .475 in (12.1 mm.)
Micrometals	ST150-275B	OD 1.52 in (38.6 mm) ID 0.835 in. (21.2 mm.) HT .825 in (21 mm.)
Micrometals	ST200-275B	OD 2.01 in (51.1 mm) ID 1.24 in. (31.5 mm.) HT 1.025 in (26 mm.)
Magnetics	77930-A7	OD 1.09 in (27.7 mm) ID .555 in. (14.1 mm.) HT .472 in (11.99 mm.)
Fair-Rite	2643803802	OD 2.4 in (61 mm) ID 1.4 in. (35.55 mm.) HT 0.5 in (12.7 mm.)

Manufacturer	Manufacturer's Part #	Danaher Motion Kollmorgen Part #	Description
Schaffner	RD7137-36-0m5	A-96843-005	500 $\mu$ H 3 phase common mode choke. 36 amps continuous.
Schaffner	RD8137-64-0m5	A-96843-010	500 $\mu$ H 3 phase common mode choke. 64 amps continuous.

## I/O Filtering

I/O filtering, while not a necessity for CE compliance, may be desirable (depending on system installation, application, and integration with other equipment). To avoid unwanted signals entering and disturbing the drive system or other associated equipment, place ferrite cores on I/O lines. The following chart lists some recommended ferrite parts used for I/O filtering and noise attenuation. These parts are ideal for providing an in-line common mode impedance for I/O lines (Fair-Rite Products Corporation also has a varied selection for most applications).

Manufacturer	Manufacturer's Part #	Danaher Motion Kollmorgen Part #	Description
Ferrishield	SS33B2032	A-96770-003	Clamp on core
Ferrishield	SS33B2036	A-96769-005	Clamp on core
Ferrishield	FA28B2480	A-96771-003	Clamp on core - flat cable clamp
Ferrishield	SA28B4340	A-96772-009	Clamp on core - flat cable clamp
* Fair-Rite	2643167251		



*\* This core must be used with the CD-Series of drives for CE compliance. It should be applied to the 24 V input power lines and the Remote Enable lines (7 & 8 on C3 connector) with approximately three turns through the core.*

The following figure illustrates the use of multiple turns through a clamp-on core. The more turns created, the more impedance is added to the line. Avoid putting the shield in a clamp-on core. It is undesirable to place an impedance in-line with the shield. The use of ribbon cable may be common in many cabinets. Some ferrite clamps are designed just for ribbon cable use.

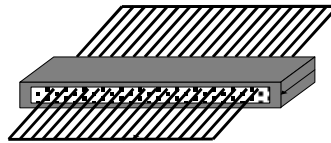
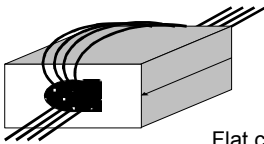

Flat cable clamp used with ribbon cable

# Cx Filter and Bonding Diagram

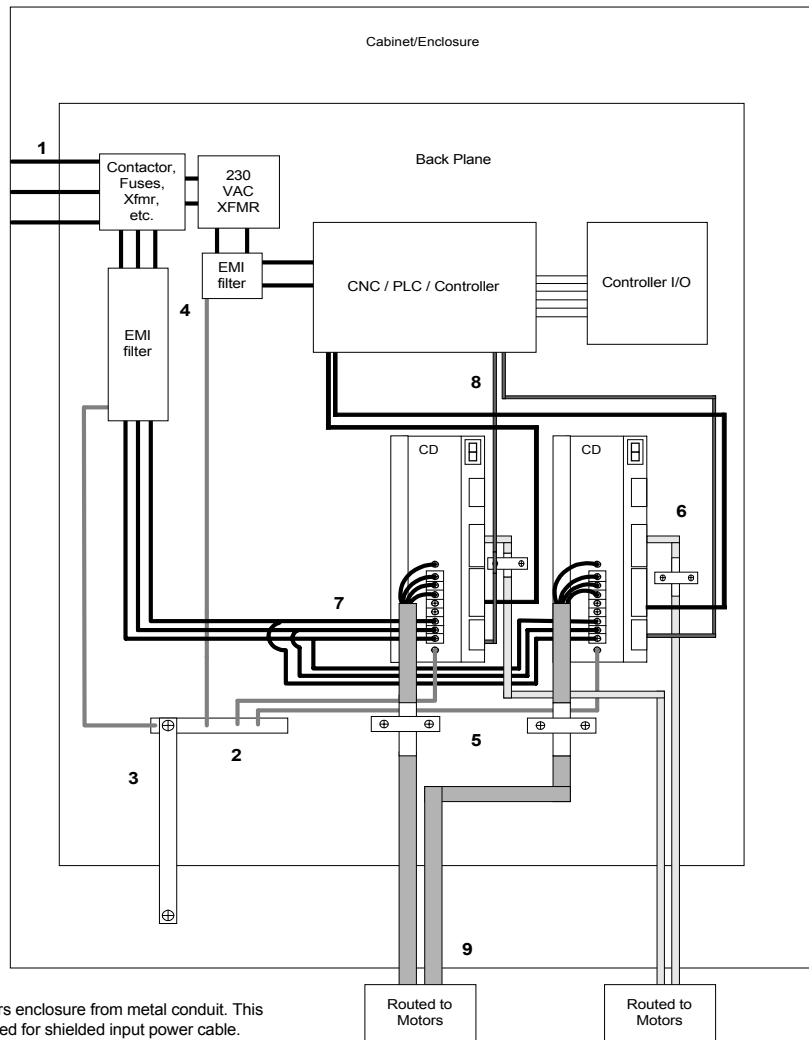

**Note 1**  
Input power enters enclosure from metal conduit. This eliminates the need for shielded input power cable.

**Note 2**  
Single point ground. A bus bar (ground bus) is an excellent way to achieve this.

**Note 3**  
High frequency ground between non-conductive back panel and enclosure. Also, a high frequency ground is required between the enclosure and earth ground.

**Note 4**  
EMI filter grounding. Safety grounds must be provided on the filters. Hazard potentials exist even when the power is off because of the capacitors internal to the filters.

**Note 5**  
Bonding of motor cables. The use of armored (screened) motor cables bonded as close to the drive as possible are essential for CE compliance and strongly recommended to better the overall performance and reliability of the system.

**Note 6**  
Feedback cable bonding is required for CE compliance. As with the motor cables, the feedback cables should be bonded to the back panel. This bonding does two things. First, it cuts down radiation from the drive, which may be in the form of high frequency energy resulting from internal processor clocks. Second, it provides immunity for the drive. Since the feedback device is located internal to the motor, it is going to pick up some noise currents and transmit them along the feedback cable. The bonding directs the currents from the shield of the feedback cable to back panel ground. This reduces the amount of noise entering the drive.

**Note 7**  
AC power lines that must be routed past other lines (such as motor cables or I/O lines) should cross at a 90° angle. This minimizes the coupling effect. Additionally, the power lines should be routed as close to the back panel as possible. Any noise currents on the lines are capacitively coupled to the ground plane and not to other lines.

**Note 8**  
Control (I/O) signals should be kept separate from all power and motor cables, if possible. Keep control wiring as short as possible and use screened wire. Bonding is also recommended but not required for CE compliance. A separation distance of 20 cm. (8 in.) is sufficient in most cases. Where control cables must cross power cables, they should cross at a 90° angle.

**Note 9**  
Motor cables and feedback cables exiting the cabinet going to the motor should be separated as much as possible. Ideally, the use of separate conduits provides good isolation, which can limit coupling of noise from motor to feedback cables.

## Sx Filter and Bonding Diagram

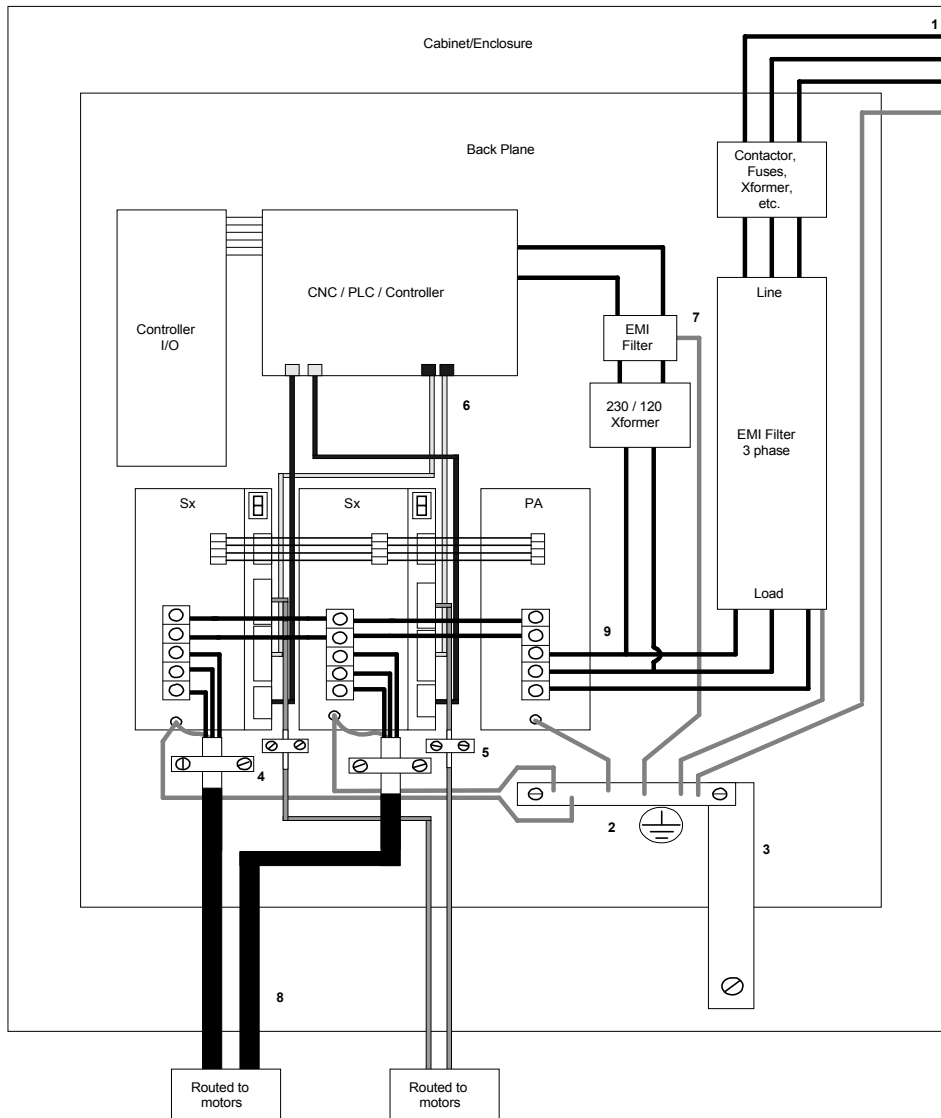

**Note 1**  
Input power enters enclosure from metal conduit. This eliminates the need for shielded input power cable.

**Note 2**  
Single point ground. A bus bar (ground bus) is an excellent way to achieve this.

**Note 3**  
High frequency ground between non-conductive back panel and enclosure. Also, a high frequency ground is required between the enclosure and earth ground.

**Note 4**  
Bonding of the motor cables. The use of armored (screened) motor cables that are bonded as close to the drive as possible is essential for CE compliance and strongly recommended to better the overall performance and reliability of the system.

**Note 5**  
Screened and bonded feedback cabling is recommended for increased immunity and lower risk of radiation. Since the motor cable and feedback cable are in close proximity at the motor, this feedback cable bonding is necessary. Also, separate the feedback and motor cables as much as possible. This decreases the chances of the feedback signals getting corrupted.

**Note 6**  
Control signals (I/O) should be kept separate from all power and motor cables. Keep all control wiring as short as possible and use screened wire. A separation distance of 20cm (8in) is sufficient in most cases. Where control cables must cross power cables, they should cross at a 90° angle.

**Note 7**  
Connect safety grounds to filters. This is critical to keep ground currents from causing personal injury.

**Note 8**  
Where motor cables exit enclosure, keep in separate wire-way or conduit from feedback and other control wiring. A separation distance of 20 cm. or 8 in. is sufficient.

**Note 9**  
Input power wires should be kept clear of I/O and signal wires.



## System Interconnect

The following sections provide connector information and the system connections up to the motor power and feedback connections. Cabling purchased from Danaher Motion Kollmorgen directly completes the system connections. Customers making their own cables can refer to Appendix A for drive/motor pinout connections.

### Cx Electrical Specifications

Product Model		Cx03*	Cx06*	Cx10
Main Input Power	Voltage (VAC <sub>L-L</sub> ) Nominal ±10%	110 to 230		230
	115 VAC	1φ or 3φ		3φ only
	230 VAC	1φ or 3φ		3φ only
	Line Frequency	47-63		
	kVA at 115	0.44 (1φ) 0.6 (3φ)	0.89 (1φ) 1.1 (3φ)	2.4 (3φ only)
	kVA at 230 VAC	0.88 (1φ) 1.4 (3φ)	1.8 (1φ) 2.8 (3φ)	4.6 (3φ only)
	Continuous Current (amps)	6.2 (1φ) 4 (3φ)	10 (1φ) 7.8 (3φ)	13 (3φ only)
	Peak Current (amps) for 500 ms	18.6 (1φ) 12 (3φ)	30 (1φ) 23.4 (3φ)	26 (3φ only)
	Peak Current (amps) for 2 sec	12.4 (1φ) 8 (3φ)	20 (1φ) 15.6 (3φ)	26 (3φ only)
	Line Fuses (FRN-R, LPN, or equiv.)	10	15	15
Logic Input Power Cxxx26x Models ONLY	+24 VDC Ext. Logic Voltage (volts)	22 to 27		
	+24 VDC Ext. Logic Current (amps sink)	1.5		
	+24 VDC Ext. Logic Current (amps max surge)	2.6		
SoftStart	Max. Surge Current (amps)	30		
	Max. Charge Time (sec)	0.25		
Protection Functions	Fault Contact Rating (amps)	1		
	Fault Contact Closing Period (ms)	Close = 3 ms, Open = 2 ms		
	Over Temperature trip	80°C (176°F)		
Rated Main Output (Ma, Mb, Mc)	Cont. Power (KVA) at 115 VAC Line Input (45°C (113°F) Ambient)	0.35 (1φ) 0.55 (3φ)	0.7 (1φ) 1.1 (3φ)	1.8 (3φ)
	Cont. Power (KVA) at 230 VAC Line Input (45°C (113°F) Ambient)	0.7 (1φ) 1.1 (3φ)	1.4 (1φ) 2.2 (3φ)	3.5 (3φ)
	Cont. Current (Arms)	3	6	10
	Peak Current (Arms) for 500 mSec	9	18	20
	Peak Current (Arms) for 2 Sec	6	12	20
	PWM Frequency (kHz)	16	8	8
	PWM Motor Current Ripple (kHz)	32	16	16
	Form Factor (rms/avg)	≤1.01		

Product Model		Cx03*	Cx06*	Cx10
Protective Functions	UnderVoltage Trip (nominal)	90 VDC		
	OverVoltage Trip	430 VDC		
	OverTemperature Trip	80°C (176°F)		
	Internal heat dissipation (watts)	60	80	132
Environment	Operation temperature	5°C (41°F) to 45°C (113°F)		
	Storage temperature	0°C (32°F) to 70°C (158°F)		
	Ambient humidity	10% to 90%		
	Atmosphere	without corrosive gasses or dust		
	Altitude	Derate 5% per 1000 ft. (300m) above 3300 ft. (1000m)		
	Vibration	0.5 g		

\*NOTE: Model Numbers Cx0x200 are single phase only!

## Sx Electrical Specifications

Product Model		Sx03	Sx06	Sx10	Sx20
Main Input (BUS+ / BUS-)	BUS (VDC)	125 to 360			260 to 360
	Rated Power at DC (kW)	0.63-1.4	1.26-2.79	1.96-4.34	8.68
Rated Main Output (MA, MB, MC)	Continuous Power (KVA) at 165 VDC BUS Input (45°C (113°F) Ambient)	0.55	1.1	1.6	N/A
	Continuous Power (KVA) at 325 VDC BUS Input (45°C (113°F) Ambient)	1.1	2.2	3.6	7.2
	Continuous Current (Arms)	3	6	10	20
	Peak Current (Arms) for 500mSec	6	12	20	40
	Peak Current (Arms) for 2Sec	6	12	20	40
	PWM Frequency (kHz)	16			8
	PWM Motor Current Ripple (kHz)	32			16
	Form Factor (rms/avg)	≤1.01			
Control Input (Sinking)	+8 VDC Supply Voltage	7.3 to 8.5			
	±15 VDC Supply Voltage	14.3 to 15.5			
	+8 VDC Supply Current (amps)	1.1			
	±15 VDC Supply Current (amps)	0.37	0.38	0.5	
Protective Functions	UnderVoltage Trip (on power-up) (VDC)	90			255
	UnderVoltage Trip (nominal) (VDC)	90			125
	OverVoltage Trip (VDC)	430			
	OverTemperature Trip (°C)	118			90
Environment	Internal heat dissipation in 45°C (113°F) ambient at continuous current (W) (not including regen)	37	84	120	240
	Operation temperature (°C/°F)	0/32 to 45/113			
	Storage temperature (°C/°F)	-20/-4 to 70/(158)			
	Humidity (non-condensing) (%)	10 to 90			
	Atmosphere	without corrosive gasses or dust			
	Altitude	Derate 5% per 1000 f.t above 3300 ft.			
Vibration (g)	0.5				

Product Model		Sx30	Sx55	Sx85
Main Input (BUS+ / BUS-)	BUS (VDC)	260 to 360		
	Rated Power at DC (kW)	13.33	24.45	37.20
Rated Main Output (MA, MB, MC)	Continuous Power (KVA) at 165 VDC BUS Input (45°C (113°F) Ambient)	N/A	N/A	N/A
	Continuous Power (KVA) at 325 VDC BUS Input (45°C (113°F) Ambient)	11	20	33.8
	Continuous Current (Arms)	30	55	85
	Peak Current (Arms) for 500mSec	60	110	170
	Peak Current (Arms) for 2Sec	60	110	170
	PWM Frequency (kHz)	8		
	PWM Motor Current Ripple (kHz)	16		
	Form Factor (rms/avg)	≤1.01		
Control Input (Sinking)	+8 VDC Supply Voltage	7.3 to 8.5		
	±15 VDC Supply Voltage	14.3 to 15.5		
	+8 VDC Supply Current (amps)	1.1		
	±15 VDC Supply Current (amps)	0.47	0.66	0.87
Protective Functions	UnderVoltage Trip (on power-up) (VDC)	255		
	UnderVoltage Trip (nominal) (VDC)	125		
	OverVoltage Trip (VDC)	430		
	OverTemperature Trip (°C)	90		
Environment	Internal heat dissipation in 45°C (113°F) ambient at continuous current (W) (not including regen)	254	465	675
	Operation temperature (°C/°F)	0/32 to 45/113		
	Storage temperature (°C/°F)	-20/-4 to 70/(158)		
	Humidity (non-condensing) (%)	10 to 90		
	Atmosphere	without corrosive gasses or dust		
	Altitude	Derate 5% per 1000 f.t above 3300 ft.		
	Vibration (g)	0.5		

***BUS Module Electrical Specifications***

Product Model		PA-LM	PA08	PA14	PA28
Main Input Power	Voltage (VAC <sub>L-L</sub> ) Nominal ±10%		110-240	110-120	208-240
	115VAC 1φ and 3φ		1/3	1/3	N/A
	230VAC 1φ and 3φ		1/3		1/3
	Line Frequency		47-63		
	KVA at 115 VAC		0.92 (1φ) 1.6 (3φ)	1.6 (1φ) 2.8 (3φ)	
	KVA at 230 VAC		1.8 (1φ) 3.2 (3φ)		3.2 (1φ) 11.2 (3φ)
	115 VAC Continuous Current (amps)		8 (1φ) 8 (3φ)	14 (1φ) 14 (3φ)	
	230 VAC Continuous Current (amps)		8 (1φ) 8 (3φ)		14 (1φ) 28 (3φ)
	115 VAC Peak Current (amps) for 2sec/50 ms		12 (1φ) 16 (3φ)	1φ:21/28 3φ:28/42	
	230 VAC Peak Current (amps) for 2sec/50msec during normal operation		1φ: 12/16 3φ: 16/24		1φ: 21/28 3φ: 56/84
	Line Fuses (FRN, LPN, or equivalent)		10	20	35
Main Output Power (Source)	DC BUS Voltage (Nominal)		140/310	140	310
	kW at 115 VAC Line Input		0.67 (1φ) 1.24 (3φ)	1.1 (1φ) 2.1 (3φ)	
	kW at 230 VAC Line Input		1.3 (1φ) 2.48 (3φ)		2.0 (1φ) 8.7 (3φ)
Logic Input Power	Voltage (VAC) Nominal ±10%		110 - 120		208 - 240
	Max. Current 1φ (amps)	1	1	1	1
	Line Frequency	47-63	47-63	47-63	47-63
	Internal Fuse (amps) (internal)	2.5	2.5	2.5	2.5
Logic Output Power (Source)	+8VDC Supply Voltage		+7.25 VDC to +8.5 VDC		
	+8 VDC Supply Current (amps)	2.2	2.2	2.2	4.4
	15 V Supply Voltage (±VDC)		14.25 to 16		
	15 V Supply Current (amps)	0.8	0.8	0.8	2.4
	Internal Fuses (amps) (±15V/+8 V)	1.5/3.5	1.5/3.5	3.5/7	3.5/7
	Max. # of Drives Sourced	Refer to the SERVOSTAR Bus Module Sizing Application Note.			

Product Model		PA-LM	PA08	PA14	PA28
	115 VAC Turn-Off Level (power-up)		70	70	
	115 VAC Turn-On Level (normal)		50	50	
	230 VAC Turn-Off Level (power-up)		70		125
	230 VAC Turn-On Level (normal)		50		112
	Max. Surge Current (amps) during power application		30		20
	Max. Charge Time (sec)		0.75	0.25	
Protection Functions	Fault Contact Rating ( $\pm 15\%$ )			1 Amp max. at 115 VAC	
	Fault Contact Closing Period (mSec)			250 ms	
	OverTemperature trip		N/A	90°C (194°F)	
Environment	Internal heat dissipation	7	45	70	130
	Operating temp. (°C/°F)	5°/41 to 45/113			
	Storage temp. (°C/°F)	0/32 to 70/158			
	Ambient humidity (%)	10 to 90			
	Atmosphere	without corrosive gasses or dust			
	Altitude	Derate 5% per 1000 ft. above 3300 ft.			
	Vibration (g)	0.5			

Product Model		PA50	PA75	PA85
Main Input Power	Voltage (VAC <sub>L-L</sub> ) Nominal $\pm 10\%$	208-240		
	115VAC 1 $\phi$ and 3 $\phi$	N/A		
	230VAC 1 $\phi$ and 3 $\phi$	3		
	Line Frequency	47-63		
	KVA at 230 VAC	20 (3 $\phi$ )	30 (3 $\phi$ )	34 (3 $\phi$ )
	230 VAC Continuous Current (amps)	50 (3 $\phi$ )	75 (3 $\phi$ )	85 (3 $\phi$ )
	230 VAC Peak Current (amps) for 2s /50ms (normal operation)	3 $\phi$ : 75/100	3 $\phi$ : 115/150	3 $\phi$ : 130/170
	Line Fuses (FRN, LPN, or equiv.)	60	80	100
Main Output Power (Source)	DC BUS Voltage (Nominal)	310	310	310
	kW at 230 VAC Line Input	15.5 (3 $\phi$ )	23.3 (3 $\phi$ )	26.4 (3 $\phi$ )
Logic Input Power	Voltage (VAC) Nominal $\pm 10\%$	208 to 240		
	Max. Current 1 $\phi$ (amps)	1	1	1
	Line Frequency	47-63	47-63	47-63
	Internal Fuse (amps) (internal)	2.5	2.5	2.5
Logic Output	+8VDC Supply Voltage (VDC)	+7.25 to +8.5		
	+8 VDC Supply Current (amps)	4.4	4.4	4.4
	15 V Supply Voltage ( $\pm$ VDC)	14.25 to 16		
	15 V Supply Current (amps)	2.4	2.4	2.4
	Internal Fuses (A) ( $\pm 15$ V/+8 V)	3.5/7	3.5/7	3.5/7

Product Model		PA50	PA75	PA85
<b>Power (Source)</b>	Max. # of Drives Sourced	Refer to the SERVOSTAR Bus Module Sizing Application Note.		
<b>SoftStart</b>	115 VAC Turn-Off Level (powerup)			
	115 VAC Turn-On Level (normal)			
	230 VAC Turn-Off Level (powerup)	125	125	125
	230 VAC Turn-On Level (normal)	35	35	35
	Max. Surge Current (amps) during power application	40	40	40
	Max. Charge Time (sec)	0.5	0.75	0.85
<b>Protection Functions</b>	Fault Contact Rating	1 Amp max. at 115 VAC ( $\pm 15\%$ )		
	Fault Contact Closing Period (ms)	250		
	OverTemperature trip	90°C (194°F)		
<b>Environment</b>	Internal heat dissipation	200	275	294
	Operation temperature (°C/°F)	5°/41 to 45/113		
	Storage temperature (°C/°F)	0/32 to 70/158		
	Ambient humidity (%)	10 to 90		
	Atmosphere	without corrosive gasses or dust		
	Altitude	Derate 5% per 1000 ft. above 3300 ft.		
	Vibration (g)	0.5		

## Cx Regen Information

Product Model		Cx03	Cx06	Cx10
<b>External Shunt Regulator</b>	Peak current (amps)	20		
	Minimum resistance (ohms)	20		
	Watts	200		
<b>Application Information</b>	Capacitance (Farads)	0.00082	0.00164	
	BUS Voltage (nominal) (VDC)	325		
	V <sub>HYS</sub> (Regen circuit turn-off) (VDC)	370		
	V <sub>MAX</sub> (Regen circuit turn-on) (VDC)	390		
<b>External Regen Kits</b>	ERH-26	✓	✓	✓

\*For guidance on application sizing of Regen Kits, see the SERVOSTAR S- and CD-Series Regeneration Requirements Application Note.

## ***BUS Module Regen Information***

Product Model		PA-LM	PA08	PA14	PA28
Internal Shunt Regulator	Peak current (amps)		N/A	30	32
	Resistance (ohms)		N/A	7.5	12.5
	Watts		N/A	40	40
	Fuse Rating (amps)(internal)		N/A	7	8
External Shunt Regulator*	Peak current (amps)		N/A	40	45
	Minimum resistance (ohms)		N/A	4.25	8.8
	Watts		N/A	300	400
Application Information	Capacitance (Farads)		0.00165	0.00165	0.00198
	BUS Voltage (nominal) (VDC)		325		
	V <sub>HYS</sub> (Regen turn-off) (VDC)		370		
	V <sub>MAX</sub> (Regen turn-on) (VDC)		390		
Internal Regen	Resistance (ohms)			12.5	12.5
	Power Rating (Watts)			40	40
External Regen Kits	ER-30			✓	✓
	ERH-40			✓	✓

\* For guidance on application sizing of Regen Kits, see the *SERVOSTAR S- and CD-Series Regeneration Requirements Application Note*.

Product Model		PA50	PA75	PA85
Internal Shunt Regulator	Peak current (amps)	N/A	N/A	N/A
	Resistance (ohms)	N/A	N/A	N/A
	Watts	N/A	N/A	N/A
	Fuse Rating (amps)(internal)	N/A	N/A	N/A
External Shunt Regulator*	Peak current (amps)	100	200	200
	Minimum resistance (ohms)	4.5	2.2	2.2
	Watts	1000	2000	2000
Application Information	Capacitance (Farads)	0.00392	0.00504	0.00504
	BUS Voltage (nominal) (VDC)	325		
	V <sub>HYS</sub> (Regen turn-off) (VDC)	370		
	V <sub>MAX</sub> (Regen turn-on) (VDC)	390		
External Regen Kits	ER-20	✓	✓	✓
	ER-21	✓	✓	✓
	ER-22	✓	✓	✓
	ER-23	✓	✓	✓

\* For guidance on application sizing of Regen Kits, see the *SERVOSTAR S- and CD-Series Regeneration Requirements Application Note*.

***Kit Parts and Models***

Kit Parts / Kit Models		ER-20	ER-21	ER-22	ER-23
Resistor	Resistance (ohms)	4.5	4.4	2.2 (two in parallel)	2.2 (two in parallel)
	Power Rating (watts)	500	1000	1000	2000
	Danaher Motion Kollmorgen Part No.	A-79916-007	A-93317-027	A-79916-007	A-93317-027
Overload Relay (Fast Trip)	Relay Trip Setting (amps)	10.5	15	21	30
	Danaher Motion Kollmorgen Part No.	A-93142-007	A-93142-008	A-93142-010	A-93142-010
	Auto/Manual Setting	Manual	Manual	Manual	Manual
Hookup	Wire Gauge / Temp. Rating	#8 AWG/125°C			

Kit Parts / Kit Models		ER-30	ERH-26	ERH-40
Resistor	Resistance (ohms)	8.8	20	8.8
	Power Rating (watts)	400	200	100
	Danaher Motion Kollmorgen Part No.	A-84776-001		P-97742-001
Overload Relay (Fast Trip)	Relay Trip Setting (amps)	7	N/A	N/A
	Danaher Motion Kollmorgen Part No.	A-93142-006	N/A	N/A
	Auto/Manual Setting	Manual	N/A	N/A
Hookup	Wire Gauge / Temp. Rating	#8 AWG/125°C		



# Wiring Diagrams

## *Bus Module Simplified Schematic*

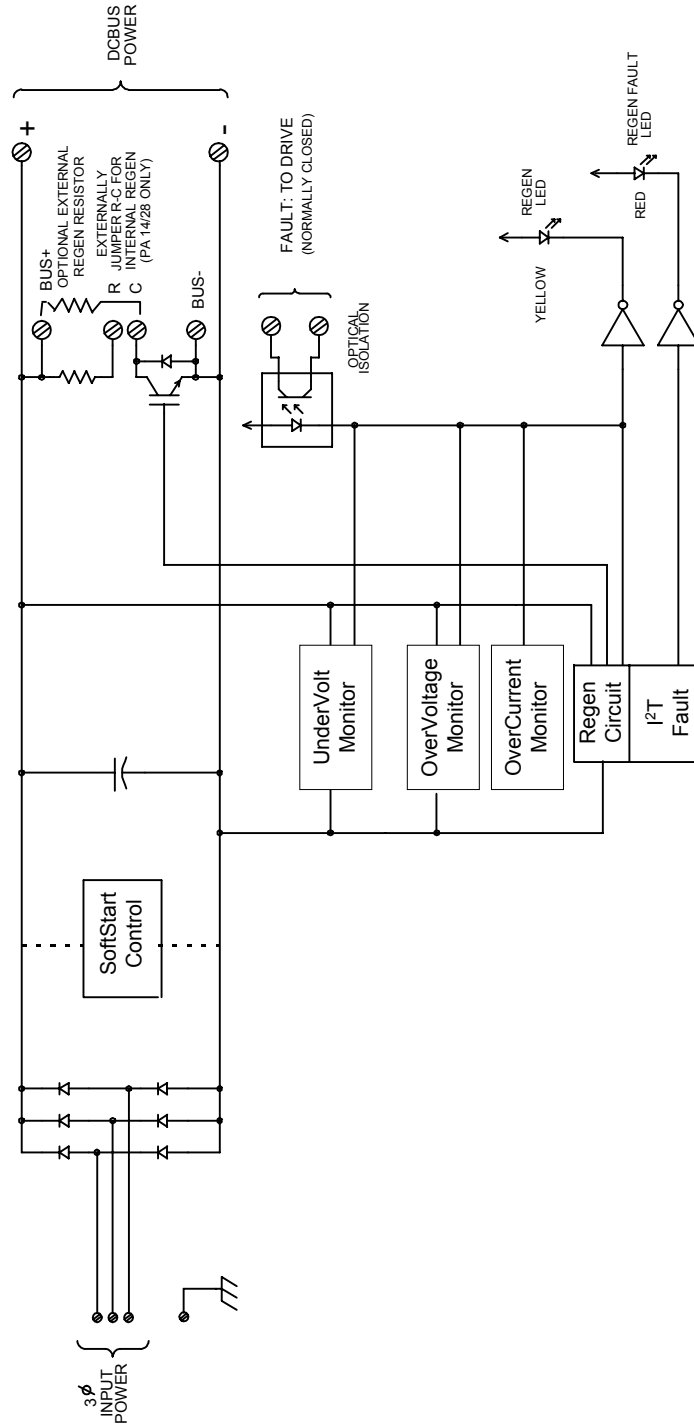

# Cx Wiring Diagram

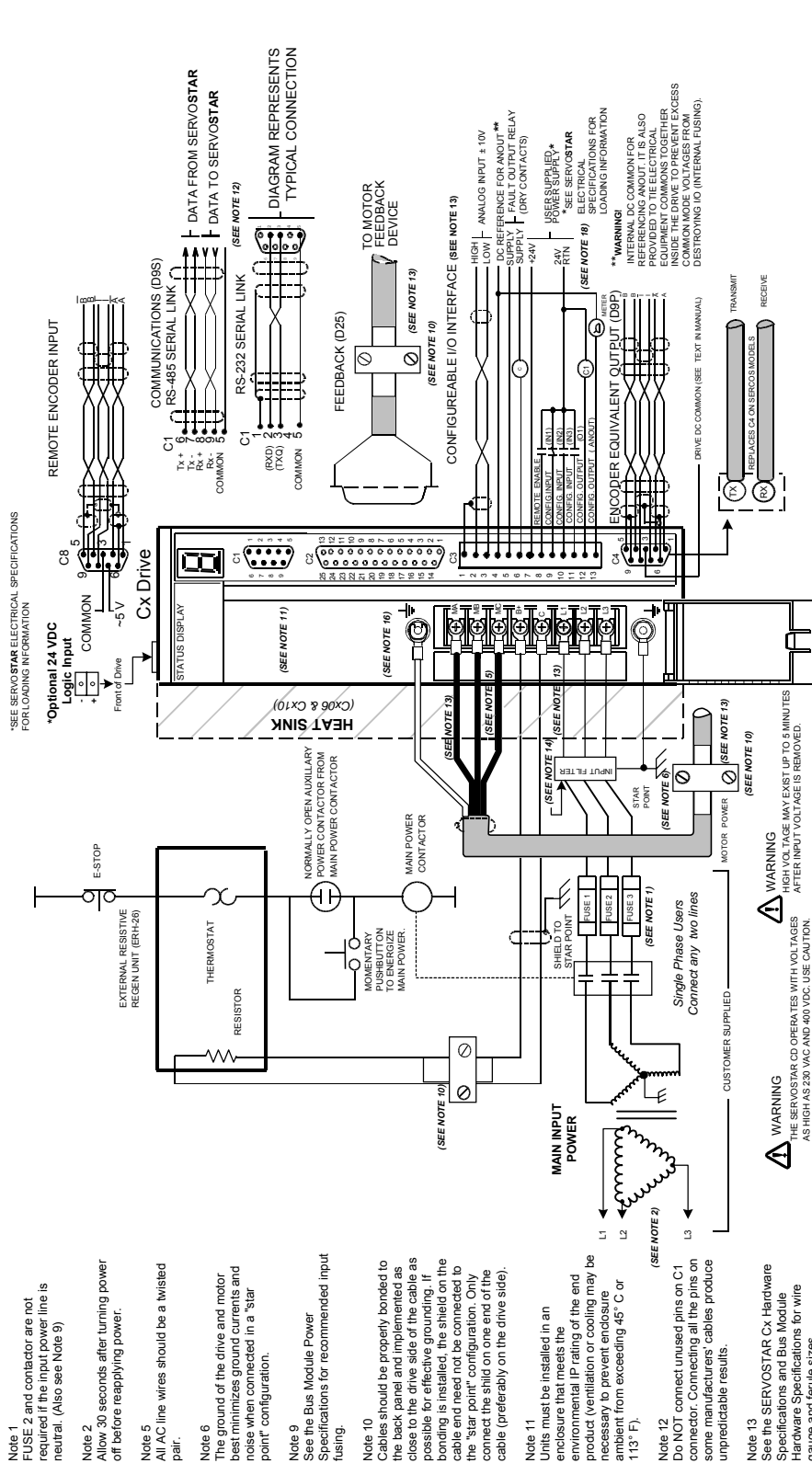

Note 17 This system is suitable for use on a circuit capable of delivering not more than 5000 RMS symmetrical amperes, 240 V maximum.

Note 18 A flyback diode is necessary for inductive loads connected across the 01 output.

# Sx with PA08, 14, or 28 Wiring Diagram

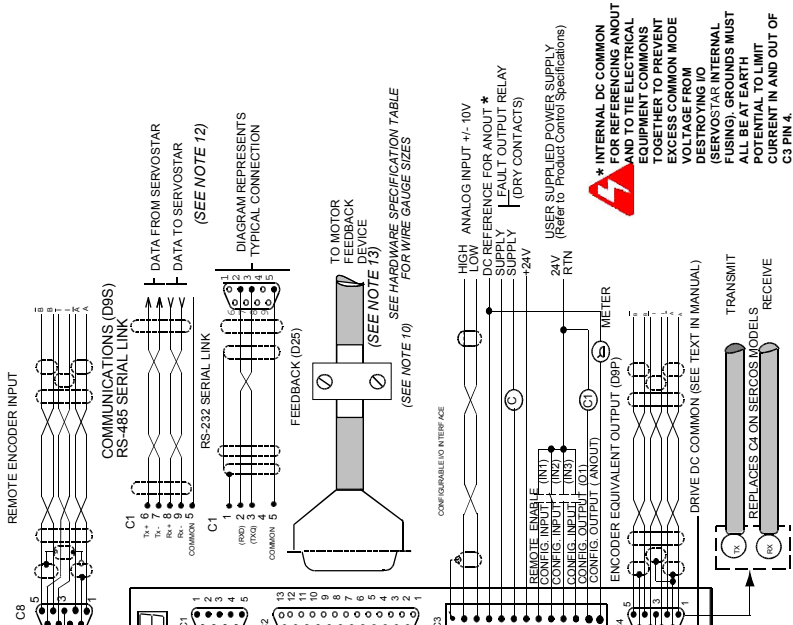
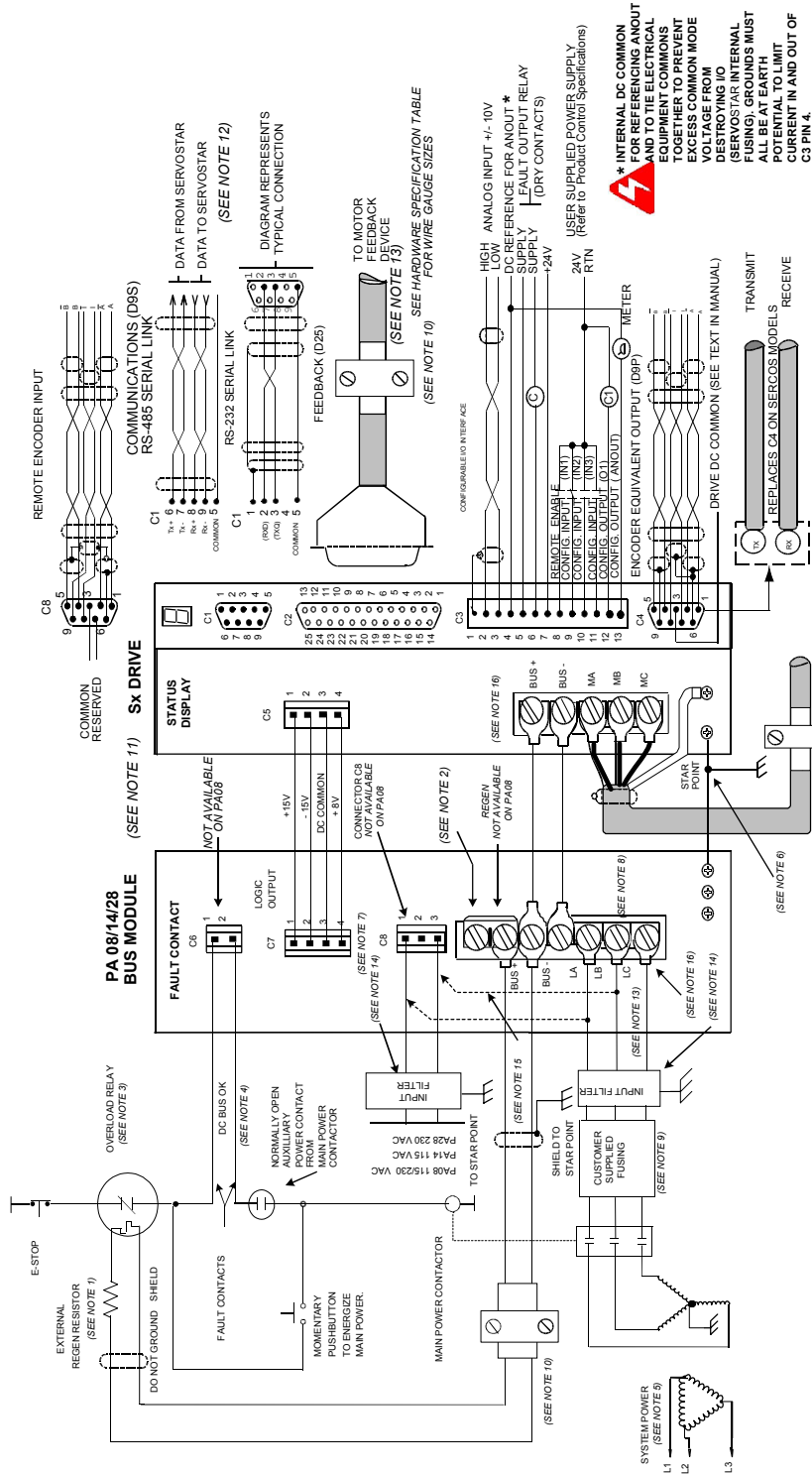

**\* INTERNAL DC COMMON FOR REFERRING ABOUT THE CONNECTIONS TOGETHER TO PREVENT EXCESS COMMON MODE VOLTAGE FROM DESTROYING I/O (SERVOSTAR INTERNAL FUSING). GROUNDS MUST ALL BE AT EARTH POTENTIAL TO LIMIT CURRENT IN AND OUT OF CS PIN 4.**

- Note 11**  
Units must be installed in an enclosure that meets the requirements for fire and explosion protection or cooling may be necessary to prevent enclosure ambient from exceeding 45°C or 113°F.
- Note 12**  
Do not connect unused pins to CS connector. Some manufacturers' cables connecting all the pins may produce unpredictable operation.
- Note 13**  
See the SERVOSTAR Sx Hardware Specifications and the BUS Module Hardware Specifications for wire gauge and ferrule sizes.
- Note 14**  
See the CS Pin 4 Wiring Techniques for further information.
- Note 15**  
Control logic input can be lapped directly off the main line input. If this source is used, the main line power is lost and all motion functions to the drive cease.
- Note 16**  
See the SERVOSTAR Sx Hardware Specifications and the BUS Module Hardware Specifications for specific terminal sizes.
- Note 17**  
This is suitable for use on a circuit capable of delivering not more than 5000 RMS symmetrical ampere, 240 V maximum.

- Note 5**  
The transformer may be omitted if correct voltage source is applied.
- Note 6**  
The end of the BUS Module drive, and order lead eliminates ground currents and noise when connected in a "star point" configuration.
- Note 7**  
See the BUS Module Power Specifications to determine the minimum number of drives that cannot be sourced by the logic supply.
- Note 8**  
The BUS Module line inputs are not phase sensitive.
- Note 9**  
See the BUS Module Power Specifications for recommended line input fusing.
- Note 10**  
The star point must be properly bonded to the back panel and ungrounded as close to the drive side of the cable as possible for effective grounding. If bonding is installed, the shield on the cable end does not need to be connected to the "star point" shield on the drive side. The shield on one end of the cable (preferably on the drive side).

**WARNING:** THE SERVOSTAR SYSTEM OPERATES WITH VOLTAGES AS HIGH AS 230 VAC AND 400 VDC. USE CAUTION AND REFER INSTALLATION AND TROUBLESHOOTING TO QUALIFIED PERSONNEL. ONLY ALWAYS REPLACE AFTER POWER HAS BEEN REMOVED!

- Note 1**  
The resistor is connected to high voltage. Please ensure sufficient electrical clearance when mounting. The resistor may become very hot during operation. Do not mount near materials that are flammable or damaged by heat. Resistor may be required to obtain specific resistance and power rating.
- Note 2**  
When using internal regem, leave the jumper installed between terminals 1 and 2. Remove these jumpers when using an external regem kit.
- Note 3**  
A thermal overload relay is supplied in the regem resistor kit. The resistor is not to be used if the thermal relay is not properly wired to drop power to the main power controller during a fault condition, as shown in the drawing. Do not wire Logic Control to the regem resistor. The regem resistor is not to be removed if the BUS Module's fault contacts are open as this resets the fault LEDs.
- Note 4**  
The bus module must be wired in series with the over-heat relay as shown in the drawing. This contact is normally open and closes after application of control and main power. This contact opens in fault conditions. Please check before BUS OK becomes active to ensure the BUS Module to remain inactive.

# Sx with PA50, 75, or 85 Wiring Diagram

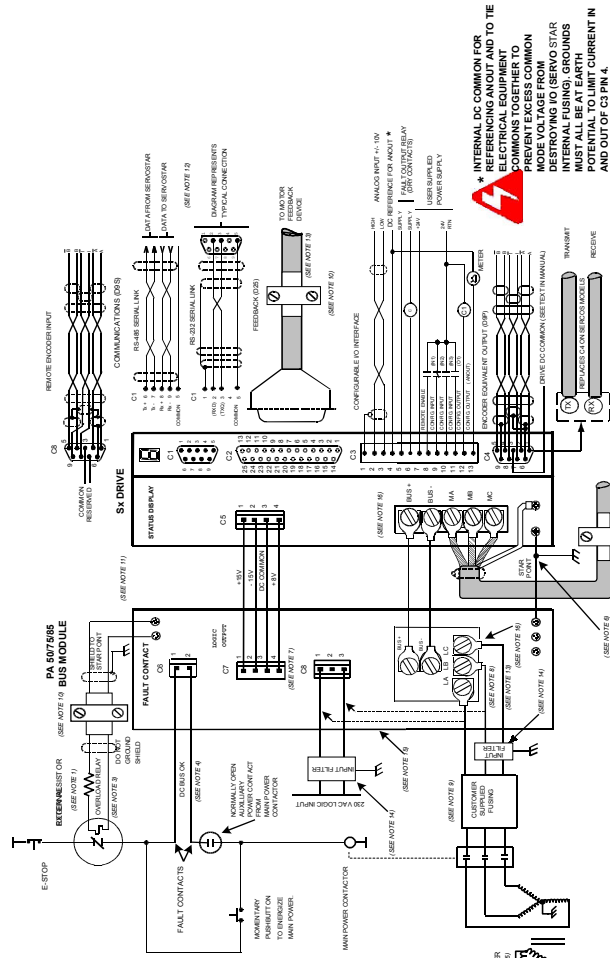

**WARNING:**  
HIGH VOLTAGE MAY EXIST UP TO 5 MINUTES AFTER POWER HAS BEEN REMOVED

**WARNING:**  
INTERNAL DC COMMON FOR REFERENCING AN OUT AND TO THE ELECTRICAL EQUIPMENT MUST BE DESTROYED TO PREVENT EXCESS COMMON MODE VOLTAGE FROM DESTROYING TO SERVOSTAR Sx DRIVE. ELECTRICAL COMMONS MUST BE DESTROYED TO LIMIT CURRENT IN AND OUT OF G3 PIN 4.

**Note 1**  
The resistor is connected to high voltage. Please ensure sufficient electrical clearance when mounting. The resistor may become very hot during operation. Do not mount near materials that are flammable or damaged by heat. Ventilation may be required. Each kit has different series and parallel resistor connectors to obtain specific resistance and power rating.

**Note 2**  
A thermal overload relay is supplied in the resin resistor kit. The thermal overload relay was sized for the resistance and power rating of the resistor. The output contacts of the relay must be wired to drop power to the main power contactor during a fault condition, as shown in the drawing. Do not wire Logic Control power through the main power contactor. Control power should not be removed if the BUS Module's fault contacts are open as this signals the fault LEDs.

**Note 4**  
The fault contacts must be wired in series with the overload relay as shown in the drawing. This contact is normally open and closes after application of control and main power. The contact opens in fault conditions.  
\*Attempting to enable the drive before BUS OK becomes active causes the BUS Module to remain inactive.

**Note 5**  
The transformer may be omitted if correct voltage source is applied.

**Note 6**  
The ground of the BUS Module, drive, and motor best minimizes ground currents and noise when connected in a "star point" configuration.

**Note 7**  
See the BUS Module Power Specifications to determine the maximum number of drives that can be sourced by the logic supply.

**Note 8**  
The BUS Module line inputs are not phase sensitive.

**Note 9**  
See the BUS Module Power Specifications for recommended line input fusing.

**WARNING:**  
THE SERVOSTAR Sx SYSTEM OPERATES WITH VOLTAGES AS HIGH AS 480 VAC. BE EXTREMELY CAREFUL AND ALWAYS USE PROPER SAFETY PROCEDURES TO PREVENT INJURY AND ELECTRICAL SHOCK. ALWAYS REPLACE AND TIGHTEN ALL ELECTRICAL CONNECTIONS TO QUALIFIED PERSONNEL ONLY. ALWAYS REPLACE



**WARNING:**  
HIGH VOLTAGE MAY EXIST UP TO 5 MINUTES AFTER POWER HAS BEEN REMOVED

**Note 10**  
Cables should be properly bonded to the back panel and implemented as close to the drive side of the cable as possible. The shield should be bonded to the main power ground. The shield should not be connected to the "star point" configuration. Only connect the shield on one end of the cable (preferably on the drive side).

**Note 11**  
The cable should be installed in an enclosure that meets the environmental IP rating of the end product (ventilation or cooling may be necessary to prevent enclosure ambient from exceeding 45°C or 113°F).

**Note 12**  
Do not connect unused drive or C1 connector. Some manufacturers' cables connecting all the pins may produce unpredictable operation.

**Note 13**  
See the SERVOSTAR Sx Hardware Specifications and the BUS Module Hardware Specifications for wire gauge and ferrule sizes.

**Note 14**  
See CE Filtering Techniques for further information.

**Note 15**  
Control logic input can be tapped directly off the main line input. If this source is used, the main line power is lost and all communication functions to the drive cease.

**Note 16**  
See the SERVOSTAR Sx Hardware Specifications and the BUS Module Hardware Specifications for spare terminal sizes.

**Note 17**  
This system is suitable for use on a circuit capable of delivering not more than 5000 RMS symmetrical amperes, 240 V maximum.

# BUS Module – PA-LM (Multiple Sx units)

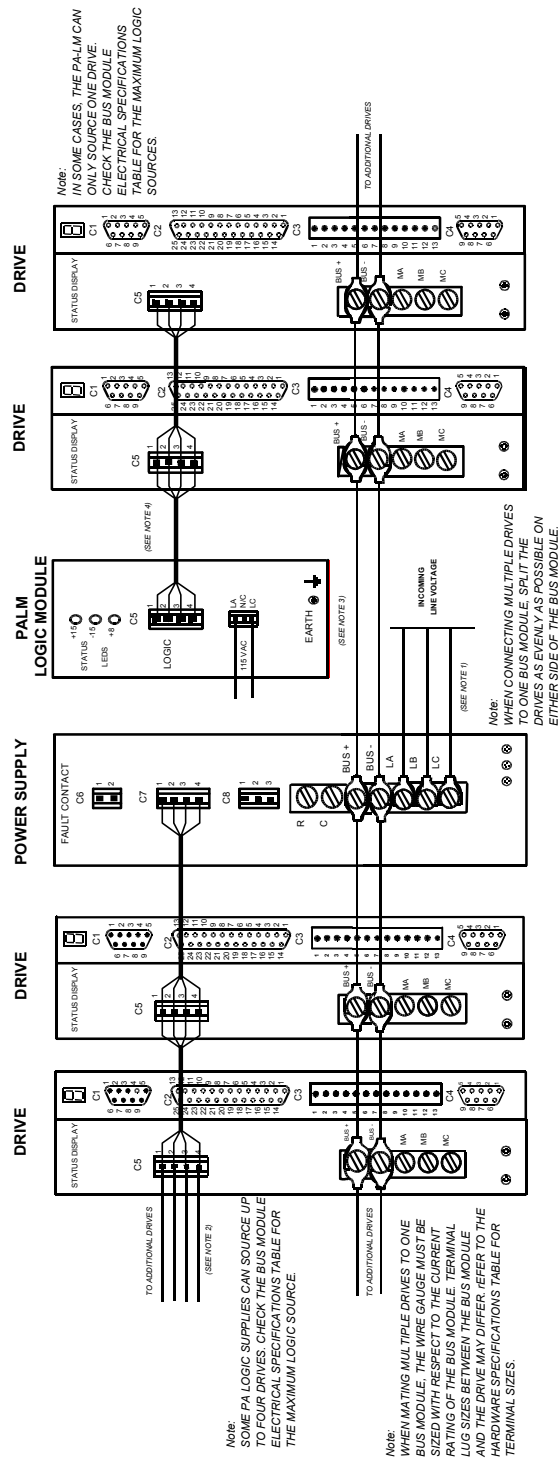

# Pin-out Connections

## Front View

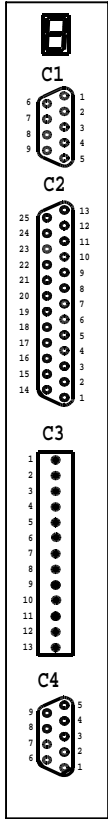

C1: Communications Connector	
Pin	Function
1	Shield
2	REC (RXD) (RS232)
3	XMIT (TXD) (RS232)
4	Reserved DO NOT CONNECT
5	Common
6	TxD+ (RS485)
7	TxD- (RS485)
8	RxD+ (RS485)
9	RxD- (RS485)

C2: Feedback Connector			
Pin	Resolver	Encoder	Sine Encoder
1	Sine High	A	A
2	Sine Low	/A	/A
3	Shield	Shield	Shield
4	Cosine High	B	B
5	Cosine Low	/B	/B
6	Shield	Shield	Shield
7		E5V Return	E5V Return
8		E5V Return	E5V Return
9		H1B	H1B (/C) (/Data)
10		H2B	H2B (/D) (/Clock)
11		H3B	H3B
12	Shield	Shield	Shield
13	Thermostat High	Thermostat High	Thermostat High
14	Shield	Shield	Shield
15	Ref. High Out	Index	Index
16	Ref. Low Out	/Index	/Index
17	Shield	Shield	Shield
18		E5V Supply	E5V Supply
19		E5V Supply	E5V Supply
20		E5V Supply	E5V Supply
21	Shield	Shield	Shield
22		H1A	H1A (C) (Data)
23		H2A	H2A (D) (Clock)
24		H3A	H3A
25	Thermostat Low	Thermostat Low	Thermostat Low

C3: User I/O Connector	
Pin	Function
1	Analog Signal Shield
2	Analog Differential Input + (High)
3	Analog Differential Input - (Low)
4	DC Reference for ANOUT
5	Fault Output Relay Contact
6	Fault Output Relay Contact
7	+24V Input (Common Rail for return pins 8,9,10,11)
8	Remote Enable Input
9	Configurable Input(See IN1 variable)
10	Configurable Input (See IN2 variable)
11	Configurable Input (See IN3 variable)
12	Configurable Output (See O1 variable)
13	*Configurable Output (See ANOUT variable)

**\* Internal DC common reference for ANOUT. It is also to tie electrical equipment commons together (inside the drive) to prevent excessive common mode voltage from destroying I/O (internally-fused).**

C4: Encoder Equivalent Output	
Pin	Function
1	Channel A Output + (High)
2	Channel A Output - (Low)
3	DC Common
4	Channel B Output + (High)
5	Channel B Output - (Low)
6	Shield
7	Index Output + (High)
8	Index Output - (Low)
9	Shield

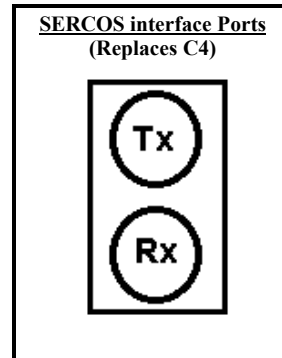

**C7: MultiDrop Communications**

Type: 10 Pin (0.1"x 0.1") Female Ribbon Cable. Connector and cable are included in the optional CK100 kit.

This connector functions only when using the R-S232 interface. It will NOT function using RS-485.

**C8: Remote Encoder Input**

Pin	Function
1	A Input + (High)
2	A Input - (Low)
3	DC Common
4	B Input + (High)
5	B Input - (Low)
6	Shield Connection
7	Reserved
8	Index +
9	Index -

See section **Error! Reference source not found.** on page **Error! Bookmark not defined.** for features using this input

*Top View*

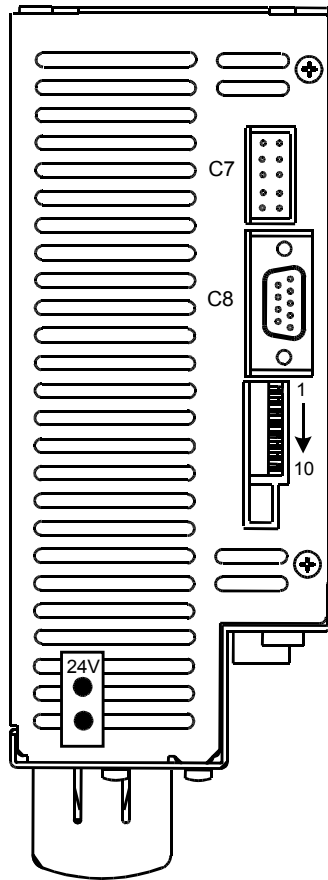

Notes for DIP switch:

The 10 position DIP switch is provided for drive configuration. The first 6 switches control communications parameters and are read only at power up. Any changes in these settings will require cycling the power. The other two switch functions (7, 8) control the motor operation and are monitored in realtime. This switch provides the following functions:

- MultiDrop Address Select: Switches 1 through 5 set the drive's address. A drive having address 0 powers up in the addressed state. If these five switches are set to anything but 0, the drive will assume an address code indicated by the switch settings.
- Baud Rate: Switch 6 sets the Serial/SERCOS interface baud rate to either 9600/2M (switch off) or 19200/4M (switch on).
- Position Hold: Activating switch 7 causes the drive to enter a position hold mode. The condition is denoted by a flashing status display. The display maintains its current OPMODE code. If the drive is running during a HOLD command detection, the motor will ramp to a stop at the DECSTOP rate.
- Enable: Switch 8 is an input to the drive enable circuitry and can be used to force the drive to a disabled state.
- SERCOS interface Power Level: Functions only on SERCOS interface products. If switch 9 is set to 0, the SERCOS interface transmitter uses a low power setting so the receiver is not overdriven when using short cables. Long cables require more power.
- Factory Reserved: Must be set to 0.

Note: Setting the switch to "1" means "Closed" or "On".

Configuration Switch		
Switch #	Function	Settings
1	MultiDrop Addressing	Bit 0 of MultiDrop Address (LSB)
2		Bit 1 of MultiDrop Address
3		Bit 2 of MultiDrop Address
4		Bit 3 of MultiDrop Address
5		Bit 4 of MultiDrop Address (MSB)
6	Serial/SERCOS Baud Rate	0 = 9600 (2M) 1 = 19200 (4M)
7	HOLD Mode Switch	0 = Hold Mode Inactive 1 = Hold Mode Active
8	Drive Enable / Disable	0 = Drive Enable 1 = Drive Disable
9	SERCOS Transmit Power	0 = Low Power 1 = High Power
10	Factory Reserved	Must Be set to 0

**24 VDC Input (CD only)**  
*Optional* Logic Supply Input  
Not all units come with the 24 VDC input.

# System Feedback Diagram

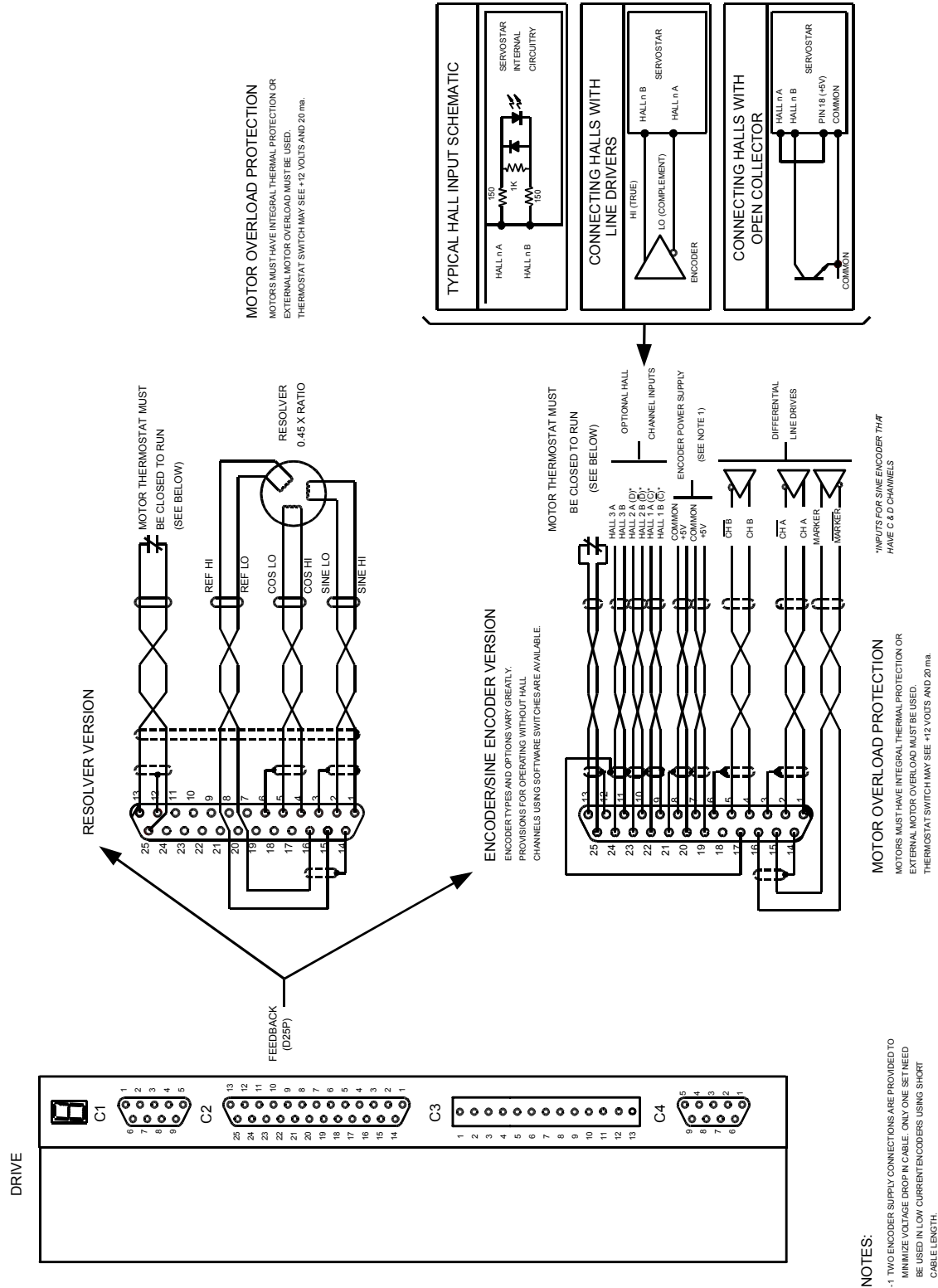



## Feedback Devices

The SERVOSTAR can receive resolver, encoder (with or without halls), or sine encoder feedback. Danaher Motion Kollmorgen offers a variety of motors with options for these various feedback devices. The device preference and the associated model number must be determined when the order is placed.

### *Resolver*

The SERVOSTAR uses either single (two poles) or multi-speed (multiple poles) resolver feedback to monitor the motor shaft position. A resolver can be thought of as a transformer whose output is unique for any given shaft position (an absolute position feedback). The transformer is driven with a sinewave reference signal. Two AC signals are returned from the resolver into the Sine and Cosine inputs. All three of these sinewave signals are low-level and susceptible to noise.

### SPECIFICATIONS

Resolver Requirements	
Type	Control Transmitter
Transformation Ratio	0.47
Modulation Frequency	7-8 kHz
Input Voltage (From Drive)	4.25 VAC
Max DC Resistance	120 Ohms (stator)
Max Drive Current	55mA AC-RMS
Output Voltage (To Drive)	2 VAC

### CABLE LENGTHS

It is important to use properly- shielded cable and to keep it away from other noise-radiating devices and cables. It is not recommended to run the feedback and motor cables in the same conduit. Danaher Motion Kollmorgen has tested cable lengths up to 75 ft. (22.9 m). without degradation of performance. However, performance may vary, depending on motor and resolver type. Tests were performed with standard Danaher Motion Kollmorgen cable and its low-impedance and Danaher Motion Kollmorgen **GOLDLINE** motor resolver. Please consult the factory for cable and resolver impedance specifications when long cable runs above 250 ft. (76 m) are desired. Danaher Motion Kollmorgen recommends twisted-shielded pair for feedback cables.

## RESOLUTION AND ACCURACY

The SERVOSTAR calculates motor velocity as the derivative of position (change in position over time). With its patented technique, all readings are extended to a resolution of 16-bit. For velocity feedback calculations, the drive converts the resolver input to 18-bits of resolution, giving smooth motor velocity control. The digital resolution (RDRES) of the Resolver-to-Digital Converter system is determined automatically according to the application velocity limit (VLIM). The following is a summary of the SERVOSTAR's resolution capabilities:

R/D Converter Specifications			
VLIM (RPM)	RDRES	Counts/Rev	Encoder Eqv. Output (C4)
> 6100	12	4096	4096 quad counts
1500 to 6100	14	16384	16384 quad counts
< 1500	16	65536	65536 quad counts

System accuracy using resolver feedback is effected by several components. The following table gives information on the inaccuracy that each of these components contribute to the total accuracy of a standard SERVOSTAR system:

**Resolver Accuracy Specifications**

Components	ArcMinutes
R/D Converter	4
Resolver mechanics (rotational)	8
Resolver mounting on motor shaft	2
Inter-LSB (digital dither over the least significant bit)	5
<b>Total (Worse-case)</b>	<b>19</b>

## Digital Encoder

The SERVOSTAR can use encoder feedback to monitor the motor shaft position. As opposed to a resolver, which is an absolute position feedback device, the encoder is an incremental device that indicates changes in position. The encoder resolution of the SERVOSTAR (and therefore the drive's encoder equivalent output) is fixed because it is a hardware characteristic of the encoder device. The encoder interface includes three groups of wires:

1. A/B (and complements) lines make up the encoder quadrature signals. The signals are received differentially through line receivers before being passed through a wire-break detection circuit.
2. The narrow Index pulse normally appears once per revolution and indicates a known physical position of the shaft. This pulse is received differentially through a line receiver before being passed through a wire-break detection circuit. This signal is hardware-capturable.

- Hall signals provide information representing the approximate absolute location of the motor shaft. From this information, the motor can sinusoidally commutate forward until the index signal is detected - at which time, true position is known. These signals are isolated by an opto-coupler and can be differential or open-collector type signals.

## SPECIFICATIONS

Encoder Requirements	
Required Signals	Types: A, B with or without Index pulse A, B, Index with or without Hall Channels * Halls may be integral or discrete
Signal Type: A-quad-B and Marker Halls	Differential: do not connect single-ended Differential or Open Collector
System Voltage	5 VDC
Maximum Input Frequency	From encoder: 3 MHz (before quad), 12 MHz (after quad)
Maximum Cable Length	System Dependent: 50 ft. (15 m) Recommended
Maximum Line Count Per Motor Electrical Cycle	10,000,000
Maximum Supply Current from SERVOSTAR	250 mA
Protection	Separate Voltage Regulator, Broken wire detector for A, B, Index, and Hall channels, Illegal Hall Code Detection

## CABLE LENGTHS

The recommended cable length when using the SERVOSTAR to source the encoder is no longer than 50 ft. (15 m). Long encoder cables tend to have high DC resistance that may create significant loading effects in the supply lines to the encoder. Please consider this carefully when designing the system. An option that would allow the use of longer lengths, implements a separate supply located at the motor to source the encoder. Quadrature signals returned to the drive are differentially connected which normally do not constitute a problem with longer cable lengths.

## RESOLUTION AND ACCURACY

A SERVOSTAR encoder-based system typically exhibits minimal inaccuracies outside of the encoder itself. To get an approximate total value the customer need only look to the specifications listed for the encoder being used.

## *Sine Encoder*

The SERVOSTAR can receive an analog (or sine) encoder feedback device to monitor the motor shaft position. As opposed to a digital encoder, which generates incremental square-wave signals, a sine encoder outputs analog differential sinusoidal signals. These sine signals are quadrature-decoded and passed to an interpolation circuit that breaks each 360° cycle into 256 parts before passing it to the drive's control board. Thus, the resolution seen by the drive is 256 times the fundamental sinusoidal track on the motor's encoder. The advantage of this approach is the ability to obtain much high encoder resolution while maintaining a relatively low input frequency through the cable and into the SERVOSTAR. The encoder interface includes three groups of wires:

1. A/B (and complements) lines make up the encoder quadrature signals. The signals are received differentially at 1V peak-to-peak amplitudes before being processed by the interpolation circuitry.
2. The narrow Index pulse normally appears once per mechanical revolution and indicates a known physical position of the shaft. This pulse is received differentially through an op amp before being squared up and sent to the control board.
3. Upon power up, commutation signals are used to communicate coarse position information. The first three signal types give approximate position information so the drive can commutate the motor forward until the Index pulse is found (There are situations where the index signal is not available. Course position information is used to commutate the motor indefinitely). The fourth gives absolute information bypassing the need for the Index signal. They are:
  - No Hall signals exist if no power-up commutation signals are available. The SERVOSTAR can excite two phases and lock the shaft in place. It then approximates position of the locked shaft and uses only the incremental signals to commutate forward until the index is found.
  - Hall signals provide information representing the approximate location of the motor shaft (6 transitions per electrical cycle of the motor). From this information, the motor can six-step commutate forward until the index signal is detected - at which time true position is known and sinusoidal commutation begins. These signals are isolated by an optocoupler and can be differential or open-collector type signals.
  - C/D lines are an alternative to Hall signals. These lines provide a SIN/COS sinusoidal signal where one electrical cycle equals one mechanical revolution (identical to single-speed resolver feedback). Interpolation is performed on these signals: thus, absolute position is known within 256 parts of a mechanical revolution. The motor can commutate forward until the Index signal is detected.

- Sine encoders with Endat capability add another approach to communicating commutation position. Here, absolute position information is stored in the encoder and is serially communicated to the drive upon power up. The data is received synchronously by a clock signal provided by the drive. Absolute position is known immediately; therefore, an index signal is not needed.

## SPECIFICATIONS

Sine Encoder Requirements	
Required Signals	Types: A, B with or without Index A, B, Index with discrete Hall Channels A, B, Index with C, D once per revolution A, B, Endat
Signal Level:	1V peak-to-peak
Signal Type: A, B, Index C, D Endat (Data/Clock) Halls	Differential Differential Differential Differential or Open Collector
System Voltage	5 VDC
Maximum Input Frequency	From encoder: 125 kHz line, 500 kHz quad After Internal Drive Interpolation: 31.25 MHz line, 125 MHz quad
Maximum Cable Length	System Dependent: 50 ft. (15 m.) Recommended
Maximum Line Count per Motor Electrical Cycle	39,000 Line counts 10,000,000 Line counts after internal drive interpolation
Maximum Supply Current from the SERVOSTAR for encoders	250 mA
Protection	Separate Voltage Regulator, Broken wire detector for A, B, Index, and Hall channels, Illegal Hall Code Detection, A/B signals out of range, "burst" pulse overflow
Maximum Drive Internal Interpolation (input)	x256 (before quad)

## CABLE LENGTHS

The recommended cable length when using the **SERVOSTAR** to source the encoder is no longer than 50 ft. (15 m) Long encoder cables tend to have high DC resistance that may create significant loading affects in the supply lines to the encoder. Consider this carefully when designing the system. An option that would allow the use of longer lengths would be to put a separate supply at the motor to source the encoder. Except for noise susceptibility, signals returned to the drive are differentially connected which normally do not constitute a problem with longer cable lengths.

## RESOLUTION AND ACCURACY

Internal resolution of the system can be derived through the following calculation:

Encoder line resolution x 256 x 4 (quadrature).

System accuracy is largely dependent upon the accuracy of the encoder itself. To get an approximate total value, the customer need only look to the specifications listed for the encoder being used.

## Encoder Equivalent Output

---

The SERVOSTAR provides a motor position output to you in the form of quadrature encoder signals eliminating the need for an additional position feedback device. The outputs are differential line drivers. There is an associated DC common output (C4: pin 3) which can connect to your port to keep common mode noise and voltage spikes minimized for device protection. Because there are normally differences of potential between your controller and the drive, connection is recommended (if ground loops occur, disconnect and retest).

The source of the Encoder Equivalent Output (EEO) signals depends on the type of motor feedback device:

### *Resolver Systems*

The output signal is developed through the R/D hardware circuitry for minimal phase lag and has a maximum frequency determined by the motor speed and R/D limits. It provides a configurable (ENCOUT) resolution of up to 16384 lines (65536 quad counts) per revolution of the motor shaft. The placement of the index pulse (INDEXPOS) can be varied on resolver systems within 360 electrical degrees of the feedback signal. For single-speed resolvers, this means you can vary the position of this signal over one mechanical revolution. For multi-speed resolvers, the mechanical position variation is determined by the pole-pair count of the resolver (e.g. three-speed resolver gives mechanical variation of the pulse within 1/3 of a revolution).

### *Encoder Systems*

The output signal is the actual encoder feedback signal that is pre-configured (MENCRES) in the drive's motor parameters. It can be scaled down by multiples of two (ENCOUTO: 1, 2, 4, 8, 16) and has a maximum frequency limit of 3 MHz.

## *Sine-encoder Systems*

This output signal is developed for a resolution that is determined by a divisor (SININTOUT: 128, 64, 32, 16, 8, 4, 2, 1) of the actual sine-encoder line resolution (MENCRES). It is then encoded to a quadrature signal before being exported out of the drive. The maximum frequency limit is 1.2 MHz. A frequency limiter (MSINFRQ) is provided with burst frequency fault protection.

## *EEO Phasing*

The EEO signals are not phased the same for resolver and encoder systems. The following demonstrates these phasing relationships:

### RESOLVER SYSTEMS

A-Leads-B convention for clockwise rotation:

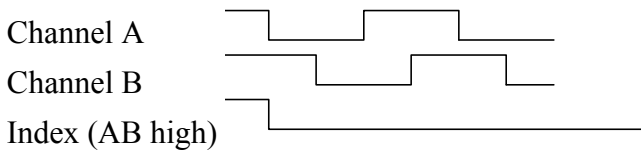

### ENCODER AND SINE-ENCODER SYSTEMS

B-Leads-A convention for clockwise rotation

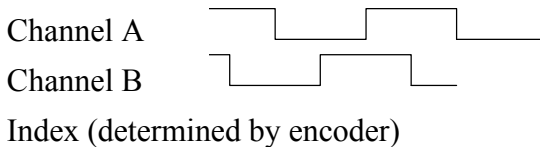

## ***Recommended Manufacturers' List***

**Schaffner** Elektronik AG      North America  
 Nordstrasse 11                Schaffner EMC Inc.  
 CH-4708 Luterbach            9-B Fadem Road  
 Switzerland                    Springfield, NJ 07081  
 Phone: 065 802 626            Phone: 201 379-7778  
 Fax: 065 802 641              Fax: 201 379-1151

### **Corcom**

<b>World Headquarters</b>	<b>East Coast Sales Office</b>	<b>West Coast Sales Office</b>
844 E. Rockland Road	17 Sarah's Way	6700 Fallbrook Ave. Suite 160
Livertyville, IL 60048	Fairhaven, MA 02719	West Hills, CA 91307
Phone: 708 680-7400	Phone: 508 992-4495	Phone 818 226-4306
Fax: 708 680-8169	Fax: 508 992-3798	Fax: 818 704-1757

### **Filter Concepts Inc.**

2624 South Rouselle Street  
 Santa Ana, CA 92707 USA  
 Phone: 714 545-7003    Fax: 714 545-4607

### **Phoenix** Contact Inc.

P.O. Box 4100  
 Harrisburg, PA 17111-0100  
 Phone: 800 888-7388  
 Fax: 717 948-3475

### **FerriShield** Interference Control Components

Empire State Building  
 350 Fifth Ave., Suite 7505  
 New York, NY 10118-7591  
 Phone: 212 268-4020  
 Fax: 212 268-4023

### **Magnetics**

P.O. Box 391  
 Butler, PA 16003-0391  
 Phone: 412 282-8282  
       (800 245-3984)  
 Fax: 412 282-6955

### **Fair-Rite** Products Corp.

P.O. Box J  
 One Commercial Row  
 Wallkill, NY 12589  
 Phone: 914 895-2055  
 Fax: 914 895-2629  
 E-Mail ferrites@fair-rite.com

### **Micrometals**, Iron Powder Cores

5615 E. La Palma  
 Anaheim, CA 92807  
 Phone: 800 356-5977  
 Fax: 714 970-0400  
 Worldwide: 714 970-9400



# SYSTEM COMMUNICATION

You communicate with the **SERVOSTAR** through either the serial port or on a SERCOS interface fiber-optic ring (SERCOS interface versions only). The serial port can transmit data at baud rates of 9600 or 19200 (DIP switch 6) in either RS-232 or RS-485 configurations. Multiple drives can be addressed simultaneously when daisy chained as described later in this section.

The **SERVOSTAR** comes with its own software interface called **MOTIONLINK**. **MOTIONLINK** is a Windows-based program designed to effectively assist you in setting up and controlling the drive's operation. It is highly intuitive in nature and contains an extensive context-sensitive on-line Help (F1) tool. The on-line Help describes how to use the program in detail and serves as a valuable reference for the drive's variable and command set, setup process, and troubleshooting techniques. This software package can be downloaded from the PSP CD-ROM accompanying this manual. Also provided on this CD-ROM is the *VarCom Reference Guide* detailing the complete variable and command set. This guide is a great added resource to **MOTIONLINK** when using the package in the Terminal mode of operation.

Since the software is designed to guide the customer through the operation process of the drive, the **MOTIONLINK** discussion in this section will cover only general steps of use. A "dumb terminal" can also be used to communicate to the drive. You will find this method of communication very awkward until a certain level of familiarity with the drive's operation is achieved.

**MOTIONLINK** also provides a terminal emulation feature that contains many useful editing tools for this type of communication.

## Computer Requirements

**MOTIONLINK** requires an IBM-PC or compatible computer with the following features:

- IBM-PC, XT, AT, 386, 486, PS/2, or compatible computer.
- 16 MB RAM.
- Windows, Windows98, or Windows NT 4.0 with Service Pack 3
- CD-ROM player
- Standard Video Adapter (CGA, MDA, EGA, MCGA, and VGA).
- Serial Port (for communication link with **SERVOSTAR**). The serial communications port may be COM1, COM2, COM3, or COM4. COM1 is the normal configuration:

COM1: Address 3F8h, Interrupt Request #4

COM2: Address 2F8h, Interrupt Request #3

COM3: Address 3E8h, Interrupt Request #4

COM4: Address 2E8h, Interrupt Request #3

## Drive Communication

---

Review and be familiar with this section completely before applying power to the system.

Most drives are shipped from the factory already configured for a particular motor. You can verify this by applying logic power and monitoring the Status Display. A factory-configured drive will go through a power-up sequence flashing all segments of the display before settling out to a number indicating the mode of operation. If the drive is not configured with a particular motor, the display will flash a minus sign “-“ indicating that you must enter drive, motor, and application variable parameters. The remainder of this section will describe the process of setting up a non-configured drive.



***Caution must be taken when applying power to the drive. It is factory configured to enable upon application of power. Verify that the hardware Remote Enable (REMOTE) enable switch is disabled.***

The SERVOSTAR has the flexibility to be addressed and controlled from a single-line or a daisy-chain (MultiDrop) configuration in RS-232-A, RS-485, or fiber-optic SERCOS interface. The first five switches of the 10-position DIP located on the top of the drive sets the binary address number for that particular drive. Switch 6 of the DIP determines the serial communication baud rate for either 9600 BPS or 19200 BPS.



***The SERVOSTAR cannot be configured for RS-232-A and RS-485 at the same time.***

### ***RS-232-A Connection***

The drive can be configured for a RS-232-A single-ended connection through the C1 connector by wiring the 9-pin mating connector. To configure for multiple units, the drives must be daisy-chained across the C7 connectors of each drive in that chain. When communicating to a single-line unit the drive's DIP switch must be set for a binary 0 address. When communicating to multiple units, the DIP switch can be set for any binary equivalent number from 1 to 31 (see table below), as desired. You can also communicate with any or all drives within the daisy chain configuration from any one RS-232-A port on that chain (called Global Addressing).

## ***RS-485 Connection***

The drive can also be configured for RS-485 differential connection through the same C1 connector. You only need to wire the 9-pin mating connector for RS-485. No software or hardware changes are necessary. Setting the drive's DIP address is identical to that described for the RS-232. When addressing multiple units, the drives must be daisy-chained across C1. You cannot daisy chain across the C7 connector in RS-485 configuration. Termination hardware is provided internal to the drive for those applications where noise becomes a problem or the host connection is single-ended. Contact the factory for instructions on how to set the drive's hardware for proper termination.

## ***Setting Drive Address***

The following table shows the MultiDrop DIP switch address settings

**(Note: OFF = 0)**

Drive Address	Switch 5	Switch 4	Switch3	Switch 2	Switch 1
* 0 (single unit addressing only)	0	0	0	0	0
1	0	0	0	0	1
2	0	0	0	1	0
3	0	0	0	1	1
4	0	0	1	0	0
5	0	0	1	0	1
6	0	0	1	1	0
7	0	0	1	1	1
8	0	1	0	0	0
9	0	1	0	0	1
A	0	1	0	1	0
B	0	1	0	1	1
C	0	1	1	0	0
D	0	1	1	0	1
E	0	1	1	1	0
F	0	1	1	1	1
G	1	0	0	0	0
H	1	0	0	0	1
I	1	0	0	1	0
J	1	0	0	1	1
K	1	0	1	0	0

Drive Address	Switch 5	Switch 4	Switch3	Switch 2	Switch 1
L	1	0	1	0	1
M	1	0	1	1	0
N	1	0	1	1	1
O	1	1	0	0	0
P	1	1	0	0	1
Q	1	1	0	1	0
R	1	1	0	1	1
S	1	1	1	0	0
T	1	1	1	0	1
U	1	1	1	1	0
V	1	1	1	1	1

**\*\* Note:** When the switch setting is set for binary 0, the drive assumes a single-line serial configuration.

## Sending/Retrieving System Data

The following chart describes the flow of data between the PC and the SERVOSTAR. When logic power is applied to the drive, it loads the variable parameters stored in EEPROM into the dynamic RAM for fast and easy access. You can read (and write) these variable parameters to (and from) the PC by one of several methods described in the INITIAL STARTUP section below.

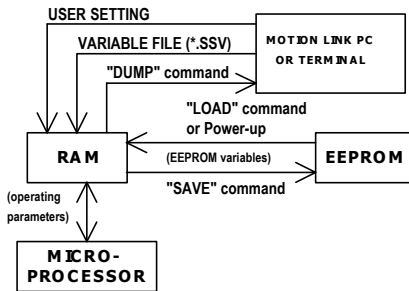

The PC transmits serial data to the drive and stores it in dynamic RAM. However, any variable data changed from the PC is lost when logic power is lost, if it is not saved into non-volatile EEPROM. Each variable listed in the *VarCom Reference Guide* indicates whether it can be saved to the EEPROM.

If you are configuring the same system on similar applications, the variables can be saved on disk in an .SSV file for convenient downloading into other drives.

---

## MOTIONLINK Installation

---

### *Installing on PC*

- Insert the SERVOSTAR PSP CD-ROM to load **MOTIONLINK** for Windows
- The CD-ROM should AUTORUN. If not, select Start | Run (or browse your CD-ROM drive)
- Type “D:AUTORUN.EXE” and hit the Enter key (this assumes your CD player has a D: letter designation).
- Select a product and follow the instructions on the screen.

### *Running the Program*

- Go to your Start/Programs listing and select **SERVOSTAR MOTIONLINK** from the menu (or click on the **SERVOSTAR MOTIONLINK** icon if loaded on the desktop).

---

## Using MOTIONLINK

---

**MOTIONLINK** gives you three methods to configure the drive. The first uses the Startup screen and is the easiest and most highly recommended approach. Its main purpose is for initial startups. The second approach allows you to more indirectly perform the same configuration as the first using the Main **MOTIONLINK** screen. This method is most convenient when corrections to an existing configuration is needed. The third method uses the Terminal Mode screen to directly set (or monitor) values for the same variables and commands that the other two methods configure through a more friendly user interface. You can gain a more thorough understanding of the **SERVOSTAR** drive, **MOTIONLINK**, and its variable and command set by using the context-sensitive Help (F1) provided in **MOTIONLINK**.

### *MOTIONLINK Startup Wizard*

This screen appears the first time (and any time after should you leave it selected) **MOTIONLINK** is run on a PC. It is designed to guide you through a step-by-step approach to configure a drive. Click the “START” button on the first user screen and walk through the complete sequence of buttons provided to set the drive, motor, and application (Opmode, Tune, Backup, Go) variable parameters.



*Should you de-activate this screen, it can be reactivated by going to the Main MOTIONLINK screen, pulling down the Configuration menu, and selecting the New Drive (123) option.*

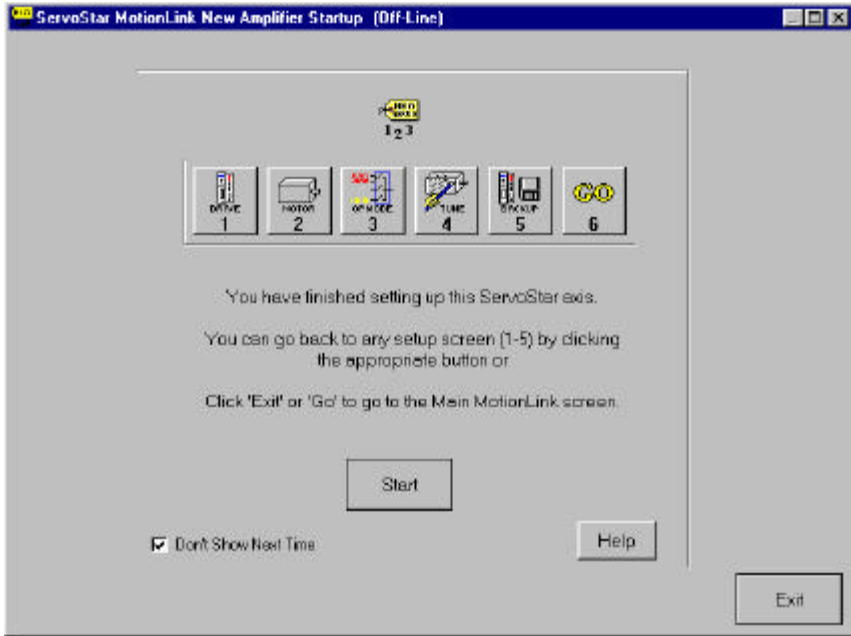

### *Startup Wizard*

- **Setting Drive Variable Parameters:** Click the Drive button. This screen allows you to select a BUS value that corresponds to the incoming line voltage. This selection actually determines the setting of the variable VBUS. Also included is a realtime monitoring of the DIP switch on top of the drive so you can verify the proper setting for the drive address, baud rate, and various other parameters. Click Exit to return to the Startup screen.
- **Setting Motor Variable Parameters:** Click the Motor button. This screen allows you to access the **MOTIONLINK** motor database. Select a motor family and then a model within that family. Information will appear in the blank parameter fields on the right. Click on the “To Drive” button beneath the fields to send the variable parameters to the drive. Click “Exit” to return to the **MOTIONLINK** Start-Up Wizard.



*If you have a configured drive, a “From Drive” button is provided to retrieve the motor data already in the drive. Retrieving this data does not erase it from the drive.*



*If the motor cannot be found in the database, click on the User Define tab. Contact Danaher Motion Customer Support for detailed instructions.*

- Customizing to Application: Click the “Opmode” button in the Startup screen to select the mode of loop control desired; position, velocity, or torque. Click Exit to return to the **MOTIONLINK** Start-Up Wizard.
- Click on the Tune button in the **MOTIONLINK** Start-Up Wizard to set the system bandwidth, the type of loop control, and the filtering necessary for the application.



*Caution should be used when executing the AutoTune feature. Some applications are not capable of handling the vibration caused as the shaft senses its load. If this is in question, manually tune the drive. Also, when the load inertia is very large and the selected bandwidth is high, this feature may fail to perform.*

- Setup Completion: Click EXIT to go to the Main **MOTIONLINK** screen.

- Saving Variable Parameters to EEPROM
- Saving Variable Parameters to .SSV file
- Restoring Factory Variable Parameters
- Restoring Custom Variable Parameters

For an explanation on these functions, refer to the Main **MOTIONLINK** screen.

## Main **MOTIONLINK** Screen

This screen appears the when you exit out of the Startup screen. All the screens mentioned in the method above can be accessed from this screen and should be used to make corrections in the current system configuration.

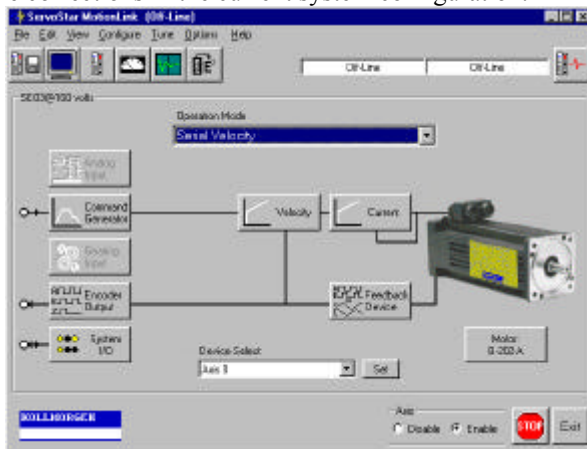

- **Setting Drive Variable Parameters:** From the Configure menu, click the Drive option. The same screen appears as described in the Startup screen section. Click Exit to return to Main **MOTIONLINK** Screen.
- **Setting Motor Variable Parameters:** selecting the Motor option under the Configure menu, you can obtain the same parameter screen found in the Startup screen. Click Exit to return to Main **MOTIONLINK** Screen.
- **Customizing to Application:** By dropping down the Operational Mode listing, you can select the mode of loop control desired (position, velocity, torque). Clicking the “Tune” button, you can select the system bandwidth, the type of loop control, and the filtering necessary for the application. These are the same parameter screens found in the Startup screen. Click Exit to return to Main **MOTIONLINK** Screen.
- **Saving Variable Parameters to EEPROM:** At the top of this screen, you can click the button labeled “RAM/E<sup>2</sup> ” to save the modified variables from RAM to EEPROM.
- **Saving Variable Parameters to .SSV file:** Occasionally, you may desire to backup the variable parameters from one drive for use in another. To do this, pull down the Edit menu and select Backup Variables, request the information from the drive (“Receive” button) into the editor, and save (“Save” button) the contents in a .SSV format to a specified disk location.
- **Restoring Factory Variable Parameters:** To restore the original factory variable parameters, pull down the Configure menu, select Motor, and select the motor family and motor model. Click the “To Drive” button to send the variable parameters to RAM and the “RAM/E<sup>2</sup> SAVE” button to save to EEPROM.
- **Restoring Custom Variable Parameters:** This process assumes that you saved the custom variable parameters to a .SSV file, as described above. To restore the custom parameters, pull down the Edit menu, select Backup Variables, and click on “Open”. Highlight the custom .SSV file to import variable parameters into editor. Click “Xmit” to send variable parameters to drive.



## *Terminal Mode*

Use the **MOTIONLINK** Terminal Mode (or any other “dumb” host) to directly monitor or modify the variable set and command the drive. This approach should only be taken when a PC with a Windows operating system is not available or you are well-versed with the **SERVOSTAR** variable and command set.

The *VarCom Reference Guide* contains the complete variable and command set. Each variable or command must be referenced for its syntax and parameter definition. The variables and commands are grouped by function for terminal users.

- **Clear EEPROM:** If a “-“ does not appear and you wish to enter a new set of variable parameters, type CLREEPROM at the terminal prompt to clear the EEPROM memory.
- **Setting Drive Variable Parameters:** At the prompt, enter a value for VBUS. Other drive parameters are determined automatically.
- **Setting Motor Variable Parameters:** Locate the motor parameter group of variables in the *VarCom Reference Guide*. At the prompt, enter values for the variable parameters listed in this group by typing the name of the variable, space, and the numerical value.
- **Customizing to Application:**  
Locate the following variable groups in the *VarCom Reference Guide*:
  - Analog Input-Related
  - Current Parameters
    - Velocity Parameters
    - Position Parameters
    - Loop Compensation and Gains Parameters
    - Motion Control ParametersAt the prompt, enter values for the variable parameters listed in these groups by typing the name of the variable, space, and the numerical value. You are strongly encouraged to develop a full understanding of these variables before finalizing the configuration.
- **Saving Variable Parameters to EEPROM:** At the prompt, type SAVE. This will save the variable parameters stored in the RAM to the EEPROM. All of the variables listed in the *VarCom Reference Guide* indicate whether its contents can be saved to EEPROM.

- **Saving Variable Parameters to .SSV file:** At the prompt, type DUMP. The DUMP command causes the drive to output variables and their contents to the serial port in the format of a variable file (this includes the trailing CONFIG command). This variable file format is an ASCII file consisting of a series of variable assignment statements. The resulting transmission of data from the drive can then be saved with a .SSV extension.
- **Restoring Factory Variable Parameters:** If you have not saved any changes stored in RAM to EEPROM, type LOAD at the prompt and the original parameters will be loaded from the EEPROM into RAM. If changes have already been previously saved, contact the factory to obtain a set of motor variable parameters for the motor specified in the model number. At the prompt, re-enter all the motor variable parameters. Type the CONFIG command followed by the RSTVAR command.
- **Restoring Custom Variable Parameters:** At the prompt, type RSTVAR. Transmit to the drive the custom variable .SSV file. The contents of this file should have the CONFIG command as its last statement. The drive will execute this command and configure itself to the parameters that were just transmitted. Follow this by a SAVE command to store the contents into EEPROM.

## MultiDrop Communication

---

When you run **MOTIONLINK**, the opening communication screen displays a “Scan For Drives” button. Selecting this forces the software to scan for any active drives (and the address location) on the chain. Any addresses detected is then listed in the Device Select drop-down menu at the bottom of the Main **MOTIONLINK** screen. You need only highlight the desired drive to begin communications.

To communicate with individual drives in a daisy chain from a terminal, you must type at the prompt:

“ \ x ” <cr> where x ∈ {0..9, A..V, \*, \}

corresponding to the DIP address setting of that desired drive. For example, to communicate to drive #8 (DIP setting: 01000) you would type at the prompt

“ \ 8 ” <cr>

To globally address all drives on the chain, type at the prompt:

“ \ \* ” <cr>

When globally addressing the drives, no character echo to the terminal occurs.

## Power-Up Sequence

Upon powering up, the SERVOSTAR performs a series of self-tests. If the Status Display illuminates a solid number, no errors were found and the EEPROM has loaded its variable parameters (or loaded with default values in case of invalid EEPROM data) into RAM. The Remote Enable switch on the I/O connector (C3) may now be energized, thus enabling the servo loops.

## Enabling the System

The drive enable logic is based on the following variable switches and flags:

**ACTIVE:** This is the overall readiness flag indicating the enable/disable state of the drive. If high (1), the drive is enabled and power is being applied to motor. The following equation must hold true for ACTIVE to go high:

$$\text{ACTIVE} = (\text{READY}) \text{ AND } (\text{REMOTE}) \text{ AND } (\text{DIPEN})$$

where  $\text{READY} = (\text{DRIVEOK}) \text{ AND } (\text{SWEN})$

**READY:** flag that indicates the drive is free of faults and ready to hardware enable

**DRIVEOK:** switch indicates the status of the drive faults.

**SWEN:** switch indicates the status of the software enable (EN or DIS).

**REMOTE:** switch indicates the status of the hardware Remote Enable line on the C3 connector.

**DIPEN:** switch indicates the state of the DIP enable/disable switch (#8)

Ready Flag		
DRIVEOK (fault status)	SWEN (software enable)	READY (drive ready)
0 (fault exists)	0 (disable)	0
0 (fault exists)	1 (enable)	0
1 (no faults)	0 (disable)	0
1 (no faults)	1 (enable)	1

Active Flag			
READY (drive ready)	REMOTE (hardware enable)	DIPEN (DIP switch enable)	ACTIVE (power to the motor)
0	X	X	0 (no)
X	0	X	0 (no)
X	X	0	0 (no)
1	1	1	1 (yes)

If the drive will not enable, you can check the state of the switches and flags by clicking the “Status” button in the upper right-hand corner of the Main **MOTIONLINK** screen. If using a terminal, you can query the drive for the value stored in the STATUS variable (refer to *VarCom Reference Guide* for an explanation on STATUS parameters). The Status Display indicates an enabled drive when the decimal point is illuminated solid.

## SERCOS INTERFACE SETUP

The SERVOSTAR S- and SERVOSTAR C-Series drives comes with SERCOS interface communication capability. It must be ordered from the factory with this option. The Encoder Equivalent Output D9 connector (C4) is replaced with two fiber-optic ports, transmitter (Tx) and receiver (Rx).

This section provides the SERCOS interface-specific information needed to complete the installation and setup of a SERCOS interface SERVOSTAR drive to the fiber-optic ring.

### DIP Switch Configuration

DIP switch configuration is similar to that of the standard SERVOSTAR drive. Through these switches, the drive's address and communication power levels are set.

#### *Setting Drive Address*

Up to 31 SERVOSTAR drives can be configured on the SERCOS interface ring. The first five switches of the DIP set the drive address. When the address is zero (00000), the drive operates as a SERCOS interface repeater and as a single-axis unit with serial communication. You can monitor and configure the drive through the serial port. Any other address setting, 1-31 (00001 – 11111), establishes the drive as an active SERCOS interface ring participant with communications through the Tx/Rx ports. When the drive has a non-zero address, you can communicate through the serial port only for monitoring purposes.

#### *Setting Transmission Power Levels*

The SERCOS interface transmitter power level (DIP switch 9) should be set according to the expected signal attenuation between a SERCOS interface transmitter and the next receiver. Signal attenuation is based upon cable length, cable type, and intermediate connection losses (e.g. bulk head connectors). The following table may be used to calculate the maximum allowable and minimum required signal attenuation for a given power level and cable attenuation:

Power Level Attenuation Specifications		
Attenuation	Low Power	High Power
Maximum	9.5 dBm. + 2 m. *Ac	12.5 dBm. + 2 m. *Ac
Minimum	-	1.5 dBm. + 2 m. *Ac

*Note: Ac = Fiber optic cable attenuation in dBm./m.*

The maximum and minimum cable lengths may be calculated by dividing the maximum and minimum signal attenuations by the cable attenuation. The following table shows the cable lengths for 1 mm plastic fiber with an attenuation of 0.18 dBm/m:

Cable Length Specifications		
Length	Low Power	High Power
Maximum	54.7 m	71.4 m
Minimum	-	10.3 m

*Note:*

- 1) *Fiber optic cable attenuation is 0.18 dBm/m.*
- 2) *Cable length calculations assume that the fiber is not attenuated by intermediate connections.*

For most applications, the low power setting is sufficient. Longer cable runs or the use of intermediate connectors may require the high power setting. Communication problems may occur if the power level at the receiver is too large or too small. Receiver power problems may cause erroneous data transfer resulting in the drive returning to CP0, or failure to advance out of CP0.

For more information on SERCOS interface signal attenuation, refer to the following sections of the IEC 61491 SERCOS interface specification:

- 5.3 - Optical Signals on the Transmission Line
- Annex G: Attenuation on the Transmission Line

## Status Display

After the CP run-up sequence has completed, the drive will be in OPMODE 5 when communicating on a SERCOS interface ring. This is indicated by the number “5” on the Status Display. The SERCOS interface version of the SERVOSTAR differs from the standard unit in that errors and faults are not communicated through this display (only through the SERCOS interface ring to the controller). Therefore, if an error occurs, the “5” remains on the display. The Status Display decimal point operates identically to that of the standard unit in that it turns ON and OFF when the drive is enabled or disabled.



***The SERCOS interface version of the SERVOSTAR is not automatically enabled on power-up, no matter what the address.***

## Connection

The mating connector selected for the Tx and Rx ports follow the IEC 874-2 specification, which recommends an F-SMA type connector. A hand-tight connection is adequate.

Danaher Motion Kollmorgen offers 30, 60, and 100cm plastic fiber optic cables with SERCOS interface compatible F-SMA connectors. The following specifications provide general cable information:

Cable Characteristics	Specifications
Cable Type	1mm plastic
Attenuation	$\leq 0.18$ dBm/m
Fiber NA	0.47
Temperature	-55° C to 85° C
Jacket material	PVC
Jacket OD	$2.2 \pm 0.07$ mm
Tensile Strength	7 kg

Also refer to the following IEC 61491 specification for more connector and cabling information:

- 5.2.2 Structure of the Transmission Lines
- 5.3.3 Fiber Optic Cable
- 5.3.4 Connectors

## Communications

The SERVOSTAR SERCOS interface drive offers two communication approaches for drive configuration. The first approach is to communicate, via a multi-axis SERCOS interface controller, all the drive parameters through the fiber-optic ring during the CP2 and CP3 run-up stages. This requires a broad understanding of the controller functionally and knowledge of the SERCOS interface standard and manufacturer's IDN set. The standard and manufacturer IDNs supported by Danaher Motion Kollmorgen are functionally categorized to make this method of configuring easier.

The second approach gives you the ability to configure each axis separately through the serial port using **MOTIONLINK**. **MOTIONLINK** is very intuitive and guides you through the setup stages of the configuration process. It provides interactive setup screens for easy manipulation of the drive's parameters while giving you realtime monitoring and recording tools that help in optimizing axis performance. Once performance is optimized, the parameters can be stored in the drive's EEPROM memory before establishing communication through the SERCOS interface.

## ***Drive Configuration***

Before you can begin the CP<sub>x</sub> (where x = 0,1,2,3,4) run-up process, the drive should be configured and tuned for the axis of operation. To accomplish this, follow the guidelines below:

- 1) Power down the drive.
- 2) Set the drive address to zero for single-axis operation.
- 3) Select a serial baud rate.
- 4) Connect a serial cable from the drive to a host.
- 5) Power up the drive
- 6) Install **MOTIONLINK** and communicate with the drive.
- 7) Follow the user screens to configure the drive and motor combination.
- 8) Enable the drive.
- 9) Tune the system as desired.
- 10) Save the drive parameters to EEPROM.
- 11) Power down and reset that actual DIP address. Any non-zero address will set the drive up for communication on the SERCOS interface ring. Each drive on the ring must have a unique non-zero address.
- 12) Set the SERCOS interface baud rate (DIP switch 6 off/on for 2/4Mbits/s)
- 13) Depending on the ring configuration, link the fiber optic cables from drive-to-drive or drive-to-master as follows: Tx<sub>1</sub> to Rx<sub>2</sub>, Tx<sub>2</sub> to Rx<sub>3</sub>, etc.
- 14) Power up the drive. It is now prepared to ascend through the SERCOS interface communication phases under the master's control.

## ***CP Run-up***

Upon power-up, the Status Display should alternately flash a "P" and a "0" to indicate SERCOS interface communication phase 0. As the drive ascends through each communication phase, the display will alternately flash a "P" and a number indicating the next sequential communication phase (phase 0-4). Upon reaching communication phase 4 (CP4), the display will briefly flash "P" and "4" before displaying a steady state "5". This indicates that SERCOS interface has been initialized and the drive and motor system is ready for commanding motion.



## CP2 INITIALIZATION

IDN 18 contains a list of IDNs that must be written to the drive in CP2. The CP2 transition procedure (IDN 127) verifies the drive's readiness to transition from CP2 to CP3 and checks whether each IDN listed within IDN 18 has been written by the master. If any IDN has been written with illegal values, then the drive will not allow a transition to CP3. If the drive fails to transition, then IDN 21 will contain a list of IDNs that are not configured properly. The following IDNs should be configured during CP2:

IDN	Description	Notes
2	Communication cycle time (tncyc).	
6	AT transmission starting time (t1).	
9	Position of data record in MDT.	
10	MDT length.	
89	MDT transmission starting time (t2).	



*Some masters do not support toggling the control unit synchronization bit (MDT control word, bit 10) during CP3 and CP4. In this case, initialize the control unit synchronization bit monitoring IDN (P152) to 0 during CP2. Refer to the IDN descriptions for more information.*

## CP3 INITIALIZATION

IDN 19 contains a list of IDNs that must be written to the drive during CP3. If the drive was properly configured using **MOTIONLINK**, IDN 19 should be empty and the master requires no IDN initialization during this phase.

## OPERATIONAL NOTES

- Remember that the hardware enables, DIP switch 8 and the Remote Enable line must be enabled before the drive can be system enabled through the MDT control word during CP4. If system enabling fails, refer to IDN P15 for a list of conditions that prevent this action.
- If a fault occurs, the drive will not allow the master to clear faults while any of the MDT control bits (13-15) are set.
- SERCOS interface Torque Units:

Standard SERCOS interface torque units are based on 0.1% of motor continuous current. However, when using **MOTIONLINK**, the torque units are based on 0.1% of drive peak current.

- SERCOS interface Velocity Units:      counts/CUCT \* 256

The following formulas may be used to convert to and from the SERCOS interface units and rpm.

$$\text{Vel \{RPM\}} = \text{Vel \{cnts/CUCT * 256\}} * 1875 / (8 * \text{Cnts} * \text{CUCT})$$

$$\text{Vel \{cnts/CUCT * 256\}} = \text{Vel \{RPM\}} * 8 * \text{Cnts} * \text{CUCT} / 1875$$

## EQUATION NOTES

- 1) Cnts = the number of encoder (or resolver equivalent) counts per revolution.  
Where:       Encoder counts = Encoder lines \* 4.  
              Resolver counts =  $2^{16} * \text{MResPoles} / 2$
- 2) CUCT = The control unit cycle time (IDN 1) in mS.
- 3) The units "CUCT/ms" is the number of CUCT periods per mS. For example, a 2 ms CUCT has 1/2 a CUCT per 1 mS.
  - Remember the following when monitoring a SERCOS interface drive through the serial port,:
    - 1) the SERCOS interface address is also the serial MultiDrop address
    - 2) SERCOS interface operation changes the UNITS variable to internal units
  - The SERCOS interface version of the **SERVOSTAR** is not enabled automatically on power-up, even with the drive address set to 0.

## SYSTEM OPERATION

The SERVOSTAR has a seven-segment indicator, called a Status Display that indicates four types of states: Power-up, Steady State, Flashing State, and Momentary State. The decimal point directly relates to the global drive enable.

Status Display	
DRIVE STATE	DISPLAY APPEARANCE
Power-up	Momentarily illuminates all display segments (forming an 8) and the decimal point.
Steady State (No Faults)	Displays the operational mode (OPMODE) of the drive (0-8).
Flashing State	Used to indicate an abnormal operating state: If the position hold feature is active, the OPMODE number will flash at a 1 Hz rate. If a fault was detected, a flashing code will be displayed to identify the fault. Some codes consist of a sequence of two or more digits (see Troubleshooting section). In general, these faults will cause a latched disable (sometimes controllable through software switches). To clear fault, toggle remote enable (except for OverCurrent). If the encoder initialization function (ENCSTART) is active, the OPMODE number will flash at a 3 Hz rate.
Momentary Fault	Displays a character momentarily for 500 ms before returning to the steady state. The timer is resettable. C = Communications Error F = Drive is in FoldBack mode

Status Display Decimal Point	
DECIMAL POINT STATE	DRIVE STATUS
Steady OFF	No power to the motor
Steady ON	Drive enabled, power to the motor
Flashing	Drive enabled, power to the motor, but a motor safety feature has been disabled (for example, LIMDIS = 1).

---

## Operational Modes

---

The SERVOSTAR has the ability to assume different modes of operation. It is factory configured in OPMODE 1 (Analog Velocity Controller) but may be reconfigur'd. Not all commands and variables are active or meaningful in every OPMODE.

1. Serial Velocity Controller (OPMODE = 0): the SERVOSTAR is configured as a velocity-loop controller and is controlled by issuing a velocity command (J: jog command, or STEP: step command) to the drive via the serial port.
2. Analog Velocity Controller (OPMODE = 1): the SERVOSTAR is configured as a velocity-loop controller and is controlled through either a  $\pm 10$  V analog input signal or jog (J) commands stored in the Configurable I/O. The commanded velocity is proportional to the input voltage.
3. Serial Torque (Current) Controller (OPMODE = 2): the SERVOSTAR is configured as a torque-loop controller and is controlled by issuing a current command (using the T command) to the drive via the serial port.
4. Analog Torque (Current) Controller (OPMODE = 3): the SERVOSTAR is configured as a torque-loop controller and is controlled via a  $\pm 10$  V analog input signal. The commanded current is proportional to the input voltage.
5. Gearing Position Controller (OPMODE = 4): the SERVOSTAR is configured as a positioning controller that can operate in one of three settings (Encoder Follower, Pulse/Direction, Up/Down Counter). The setting used is determined by the GEARMODE variable.
6. Position Controller (OPMODE = 8): the SERVOSTAR is configured as a serial or an analog positioning controller, depending on the value of PCMDMODE, that can receive simple absolute, incremental, indexing, homing, and analog commands.
7. SERCOS interface Controller (OPMODE = 5): the SERVOSTAR must be ordered from the factory as a SERCOS interface unit to establish communications in this OPMODE. The drive is shipped with Connector C4 as the Transmit/Receive port (no longer the Encoder Equivalent Output).

---

## System I/O

---

This section discusses the I/O features of the C3 connector (except for the Thermostat input on C2). For further explanation on how to use these features, refer to the *VarCom Reference Guide*.

## *Analog Input (ANIN)*

The position, velocity, or torque loop can receive its command from an analog voltage source and is selectable through the OPMODE variable. The analog input to the SERVOSTAR is differential. This means that the signals received at the two inputs are subtracted from each other to create a ‘difference’, which is then used to command the rest of the system. This type of input has a high degree of noise immunity and, in many cases, will allow for ground isolation between systems. This analog input also has a low pass filter (ANLPHZ) to prevent high frequency noise from entering the system.

The input voltage from the differential receiver is applied to a precise 14-bit Analog-to-Digital (A/D) conversion system. The A/D conversion system is read by the microprocessor every 500 $\mu$ S for the position loop modes, every 250  $\mu$ S for the velocity loop mode, and every 62.5  $\mu$ S for the torque (current) loop mode of operation. Encoder-based units come with the additional benefit of a Dual Gain (ANDG) input. When enabled, the system uses two 14-bit A/D inputs to read the user-supplied analog signal. One input is a direct reading of the  $\pm 10$ V signal, while the other incorporates a 2x gain term. When the input voltage is less than 4 V, the 2x channel is used to determine the input voltage, which extends the resolution to a 15-bit equivalent. Above 4 V, the system uses the straight 14-bit conversion. Special software algorithms are used to minimize cross-over distortion and add 0.25 V of hysteresis.

Analog systems often require scaling and offset bias. The SERVOSTAR adds an analog offset (ANOFF) variable to this reading, performs an analog deadband (ANDB) adjustment, and scales it through the either the position loop input scaling (GEARI, GEARO), velocity loop input scaling (VSCALE), or torque loop input scaling (ISCALE) before passing the data to the selected control loop. The analog input (ANIN) variable indicates the analog reading after the offset (ANOFF) and the deadband (ANDB) adjustments but before the loop scaling. The ANIN variable range is  $\pm 22500$  counts (or mV).

The SERVOSTAR also offers an automatic analog input zeroing function. Invoking the ANZERO command while the drive is enabled or disabled samples motor velocity over a 32 ms period and updates ANOFF accordingly to the analog input offset. This command also incorporates an internal offset mechanism that has finer resolution than ANOFF is capable of providing.

## ***Remote Enable Input (REMOTE)***

The opto-isolated Remote Enable input (REMOTE) provides a hardware drive enable switch. This 12 VDC to 24 VDC input will disable or enable the power stage output to the motor. The signal must be customer supplied in order to get the drive to enable (in combination with other parameters; ACTIVE) and operate. Tapping the signal off the logic supply (C5) is not recommended. The toggling of this switch will also initiate an attempt to recover from a fault condition. It can also be used to trigger various position homing features (HOMETYPE).

## ***Configurable Inputs (IN1, IN2, IN3)***

These 12 VDC to 24 VDC inputs are defined by the INxMODE variable. Placing the appropriate value in INxMODE (See the *VarCom Reference Guide* for details) sets up the inputs to be used for such features as CC/CCW hardware position limits, Electronic Gearing, serial and analog position triggering (for incremental moves and homing), fault output relay configuration, MOTIONLINK scope triggering, and more. When set for the CC/CCW hardware position limits, the inputs prevent any further motor travel in their respective direction but do not disable the drive or prevent motion in the opposite direction. Note that if acceleration control is in place (PROFMODE = 1), the motor will ramp to a stop after the opening of the End Travel Limit. These inputs are opto-isolated and considered “active enable”, meaning current must flow through these signals to allow the system to operate. This provides a ‘dead-man’ safety feature. Energizing both the CW and CCW hardware position limits causes the SERVOSTAR to enter the HOLD mode. These inputs can also be inverted (ININVx, where x = 1, 2, 3).



*The default settings of these inputs are for the hardware position limits. The Status Display may flash an ‘L’ upon power-up indicating that a travel limit has been tripped. If these position limits are not in use, set LIMDIS=1.*

## ***Configurable Outputs (ANOUT, O1)***

The  $\pm 10$  V, 12-bit analog output (ANOUT) is normally off (monitoring). The setting of this variable will allow you to meter various feedback quantities such as velocity, current, horse power, position feedback and following error, and more. This pin must be referenced to DC Common (pin 4).

The digital output (O1, O1MODE) can be toggled in an On/Off state to indicate various drive, motor, and variable conditions. These include: absolute speed and current levels, FoldBack conditions, motor braking, motion complete and zero speed conditions, position overshoot flagging, programmable limit switch detection, and an enable (ACTIVE) flag. Condition, reset, and triggering levels are established through O1MODE, O1RST, O1TRIG.

## ***Fault Output Relay (RELAY, RELAYMODE)***

The SERVOSTAR provides a drive ready/drive up output in the form of a relay (RELAY) output. The relay (RELAY) output is controlled by the SERVOSTAR's microprocessor. There is a software switch (RELAYMODE) that configures the relay (RELAY) output to act as a 'Drive Ready' or 'Drive Up' indicator:

1. **If RELAYMODE = 0**, the relay is closed when the drive is error free and ready to run. This is a 'Drive Ready' configuration.
2. **If RELAYMODE = 1**, the relay is closed only when the drive is enabled. This is a 'Drive Up' configuration.
3. **If RELAYMODE = 2**, the relay opens during a fault when the drive is disabled.



*You can program this fault output to open on any system fault by triggering the Configurable Inputs (IN1MODE, IN2MODE, IN3MODE, IN1, IN2, or IN3)*

## ***Motor Thermostat Input (THERM, THERMODE)***

The SERVOSTAR provides a motor thermostat input on the C2 connector that is configured for different types of thermal protections (THERMTYPE), as well as manipulation of how the drive responds to a motor thermal condition (THERM, THERMODE, THERMTIME). Danaher Motion Kollmorgen GOLDLINE motors and cables connect the thermostat through the feedback cable. The input to the SERVOSTAR is electrically closed through the thermostat for proper operation. The drive normally flashes an 'H' in the Status Display when this input is electrically opened.



*If a motor thermal device is not used, set THERMODE to 3 to disable the feature (turns the 'H' status display indicator off).*

## **Control loops**

---

This section describes the servo control loops, their characteristics, and how to configure them.

## Core Processors

A 40 MHz embedded controller and a 40 MHz DSP controller are the heart of the SERVOSTAR. They use its internal operating system to monitor inputs, adjust outputs, communicate serially, maintain servo control, and monitor faults. The flash memory firmware controls the core processor and gives the SERVOSTAR its operating characteristics saved in EPROM. The version number of the firmware is read using the VER command. When calling Danaher Motion for technical support, have the firmware version number readily available. The most recent version of firmware is available for purchase and is easily field-upgradable through a PC. It is obtained by contacting a sales representative or Danaher Motion Customer Support.

## Servo Loop Description

The SERVOSTAR provides high performance motor control by controlling up to four distinct closed loop systems within the DSP: the current, commutation, velocity, and position loops. The next figure depicts the control loops graphically.

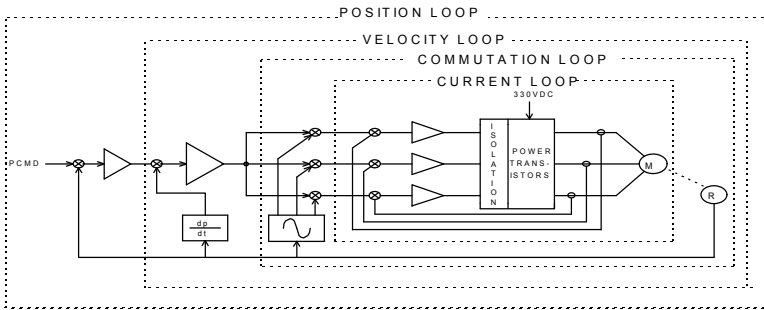

## CURRENT LOOP

Since current and torque are proportional in a Permanent Magnet (PM) motor, the current loop is often referred to as the torque loop. The function of the current loop is to regulate motor current as directed by a current command signal. The current command signal from the microprocessor can either come from a direct user input (OPMODE 2 & 3) or from the output of the velocity loop. There are actually three current loops, one for each motor phase. Each current loop receives its own command input from the commutation loop.



The **SERVOSTAR** uses a fully digital, pole placement current loop with high bandwidth and a current loop sampling rate of 16 kHz (62.5  $\mu$ S.). All coefficients of the current loop are digitally calculated inside the drive for a given set of motor and drive characteristics. The current loop also includes adaptive gain terms to compensate for some non-linear effects.

The current loop incorporates electrical isolation for protection from the high-voltage BUS. These current loops also convert the output voltage to a Pulse Width Modulated (PWM) signal providing the highest efficiency possible. The PWM center frequency can be 8 or 16 kHz according to the drive size.

## COMMUTATION LOOP

This loop converts a single-phase current command signal into a three-phase, position-modulated sine wave input to the current loops. The **SERVOSTAR** has a patented sinusoidal wave form generator, which uses a technique called Torque Angle Advance to get top performance out of its motors. The waveform generator is part of the microprocessor and is updated at a 16 kHz rate. This provides hi-fidelity sinewave commutation at both low and high velocities. The sinewave output must be aligned to the back EMF (MOTORBEMF) characteristics of the motor. This is why resolver or encoder alignment to the motor is critical.

## VELOCITY LOOP

The purpose of the velocity loop is to regulate motor speed. Like the current and the commutation loops, the velocity loop is fully digital and uses the resolver or the encoder feedback signals to calculate actual motor velocity. The command for the velocity loop can come from a direct user input (OPMODE'S 0&1) or can be the output of the position loop. The velocity loop is a digital sampling system operating at 4 kHz.

The difference between actual and desired velocity is filtered through a compensator algorithm and fed to the commutation loop. The **SERVOSTAR** offers four velocity compensators (methods of regulating velocity) and are selectable through the COMPMODE variable. The four are: Proportional-Integral (PI), Pseudo-Derivative-Feedback with Feed-Forward (PDFF), Standard Pole Placement, and Extended Standard Pole Placement.

## POSITION LOOP

The final control configuration is the position loop. The purpose of this loop is to maintain motor shaft position. Like the previous loops, the position loop is fully digital and uses resolver, encoder, and sine encoder feedback signals to determine actual motor position. The drive can also accept a position signal from an external feedback device (e.g., load encoder). It samples at a rate of 2 kHz and can be configured for three different modes of operation:

**OPMODE 4:** This mode of operation sets the **SERVOSTAR** up to run as a pulse (or master encoder) follower by using the Electronic Gearing feature. The pulse input can either be applied through the Configurable Inputs on the C3 connector (up to 2.5 KHz max. - opto-isolated) or through the Remote Encoder Input on the C8 connector (up to 3 MHz) on top of the drive.

**OPMODE 8:** This mode of operation configures the **SERVOSTAR** as a simple positioning controller. Once in this mode, position commands can be given through the serial port, through the Configurable I/O, or through the analog input (determined by the PCMDMODE variable). The position loop has been enhanced to a full PID controller with acceleration and velocity feed-forward gains. Two integral gain variables have been added to limit the action of the integral term during selected parts of the profile. This helps to minimize overshoot and settling problems.

Using a serial command (PCMDMODE=0), the **SERVOSTAR** executes simple absolute, incremental (or indexing), and homing motion profiles. This is done either by direct commands through the serial port (MI, MA, MH) or by pre-configuring a profile in memory to be used in conjunction with the Configurable I/O (MASPEED, MISPEED0-3, MAPOS, O1, O1MODE, INx, INxMODE).

Using an analog command (PCMDMODE=1), the **SERVOSTAR** scales the analog input (GEARI, GEARO) to establish a wide range of relationships between an analog input adjustment and a corresponding shaft movement. Homing types (HOMETYPE) are available that home to a particular analog input level (and position count), triggering either through the Configurable Inputs or the Remote Enable.

In this mode of operation, the drive can also accept an external load feedback signal through the C8 connector (DUALFB=1). This helps eliminate the positional inaccuracies, due to gear backlash and poor coupling, by positioning according to the load's position (not the motor shaft's position).

The **SERVOSTAR** also operates in the position mode when the drive is in the hold position state (HOLD = 1).

## ***Torque Loop Operation***

The design of the control loops was discussed in the previous section. Now, the operation as a system is presented. The SERVOSTAR has many internal variables that are used to examine and dictate system operation. Many of these variables and their locations in **MOTIONLINK** are presented graphically in the following discussions to help disclose meanings and relationships.

### **SERIAL TORQUE**

The SERVOSTAR can be operated as a serial torque-controlled amplifier (OPMODE 2). It receives a serial command (T) via a host to a command generator, which in turn creates a current command (ICMD). The current (or torque) command is checked against peak (IMAX, ILIM) and continuous (FoldBack features, ICONT) current clamp limits. Sinusoidal commutation modulation is added to the command and then fed to the three-phase current loop regulator, which calculates a current error. This error is then fed through a digital pole-placement compensation algorithm. The output of the compensator is converted to a PWM signal and fed to the power transistor bridge. The power bridge uses the high voltage DC BUS Module (typical 325 VDC bus) to supply the required current to the motor windings. The actual motor current is updated and the process begins again. The following graphic is a representation of the serial torque loop operation (refer to the *VarCom Reference Guide* for details on all variables and commands).

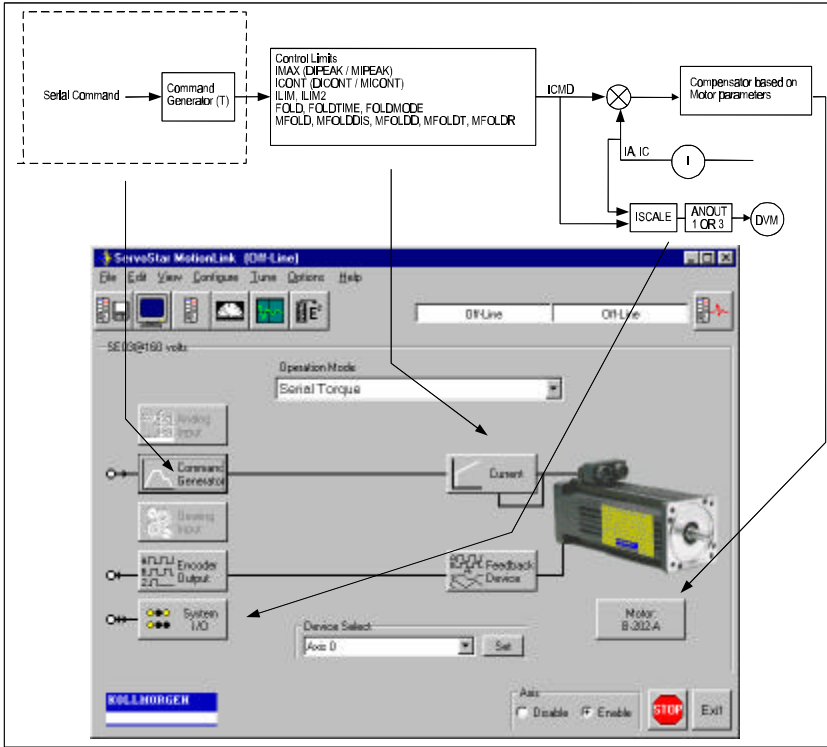

## ANALOG TORQUE

The SERVOSTAR can be often configured to operate as an analog torque loop controller (OPMODE 3). In this case, the current loop receives its input from the analog-to-digital (A/D) conversion system. After conversion, the input command signal is processed through an algorithm which adjust the signal (ANOFF, ANDB, ANZERO), filters it (ANLPHZ) and then scales it (ISCALE), before developing the current command (ICMD). The current (or torque) command is then checked against peak (IMAX, ILIM) and continuous (FoldBack features, ICONT) current clamp limits.

Sinusoidal commutation modulation is added to the command and then fed to the three-phase current loop regulator, which calculates a current error. This error is then fed through a digital pole-placement compensation algorithm. The output of the compensator is converted to a PWM signal and fed to the power transistor bridge. The power bridge uses the high voltage DC BUS Module (typical 325 VDC bus) to supply the required current to the motor windings. The actual motor current is updated and the process begins again.

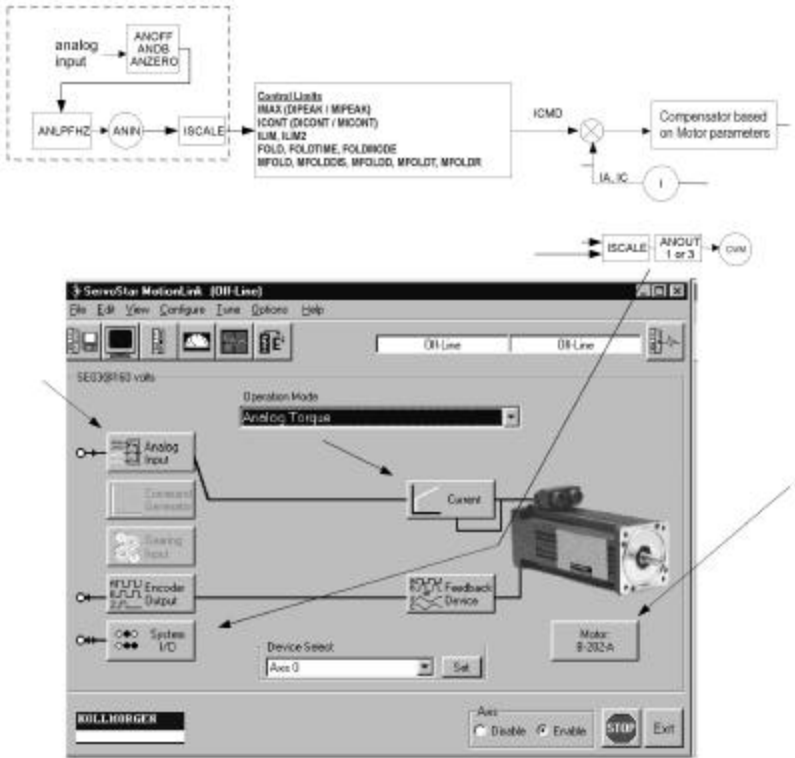

## Current Sampling

The current loop receives corrective feedback from the current sampling circuitry. The current sensors use closed-loop hall sampling techniques in all units.

The current sample is used by the current loops to regulate the current in each of the three motor phases. Two phases (A and C) of the current signal are sampled by the microprocessor at a 16kHz rate. The momentary A phase current and C phase current can be monitored by examining the IA and IC variables, respectively. The microprocessor calculates the equivalent absolute current, which can be monitored as I. This value can be averaged for 2, 4, 8, 16, 32, or 64 samples.

## Foldback

---

The SERVOSTAR offers two types of FoldBack protection for both the motor and the drive. The drive's microprocessor monitors the current feedback signal and develops a RMS value of this signal for the purpose of providing a value that represents the current in the motor. The system is similar to an "I-squared-T accumulator."

### *Drive FoldBack*

This FoldBack algorithm monitors current feedback and, if the feedback exceeds the continuous current rating of the drive/motor combination (ICONT), will decrease the system's current to the ICONT level. For example, under a step command input condition, the FoldBack algorithm will allow maximum peak current (IMAX) output from the drive for 2 seconds (or 1/2second for Cx units). After two seconds, the drive enters "FoldBack mode" (FOLD = 1) and begins an exponentially FoldBack to the system's continuous current. It will take approximately six seconds for the exponential decay to drop from the system's peak current to its continuous level.



*For drive currents that exceed ICONT, but are below IMAX, the system period before FoldBack occurs is extended beyond two seconds. Two seconds is the shortest time period that will elapse before the drive enters FoldBack and only occurs when maximum peak current (IMAX) is drawn.*



*This FoldBack feature is designed to protect the drive electronics, not the motor. The Configurable Output, O1, (pin 12) can be configured to indicate a drive FoldBack condition.*

### *Motor FoldBack*

This FoldBack algorithm is designed to provide motor protection in cases where the drive's continuous current rating is above the motor's continuous rating. This combination is often desired in applications where maximum peak motor torques are required. However, the possibility exists that the drive could source current on a continuous basis indefinitely to the motor and would force it beyond its thermal capability. Unlike the drive FoldBack, you have complete configurability over this feature (MFOLD, MFOLDD, MFOLDDIS, MFOLDR, MFOLDT).

## SYSTEM DESCRIPTION

The SERVOSTAR S or SERVOSTAR CD is a digital servo motor amplifier that meets the needs of many servo applications such as machine tooling, packaging, electronic assembly, and document handling. It has been designed to be a multifaceted amplifier, capable of driving Danaher Motion Kollmorgen's vast product basket of motors and their assorted feedback devices. The S-series of drives come in standard packages of 3, 6, 10, 20, 30, 55, and 85 amps. A C-series (Compact Drive that includes an integrated BUS Module), is available in 3 and 6 amp sizes. All are packaged in a small frame size for minimizing cabinet space. This product can be commanded through analog, serial, and SERCOS interface user interfaces and has its own tailored software environment in Danaher Motion Kollmorgen's **MOTIONLINK** for Windows.

## Product Features

The SERVOSTAR S or SERVOSTAR CD includes a vast array of features. Its various control techniques, interfaces, and user tools give the customer a compatible drive to meet most motion control applications. User features include:



*Bulleted words that begin in capital letters indicate formal feature names. Words that are capitalized indicate the software variables and commands associated with the feature. This section is designed to direct you to the VarCom Reference Manual for details on these features.*

### *Current/Torque Control*

- Digital current loop control (Torque Mode - OPMODE 2 or 3) receiving serial (T) or analog commands.
- Pulse Width Modulated (PWM) sine wave commutation (PWMFRQ) providing smooth and precise low-speed control and high-speed performance.
- Current loop adaptive gain (MLGAINC, MLGAINP, MLGAINZ).
- System current-limiting capability (ILIM, ILIM2, IMAX, MICON, MIPEAK).
- Exponential current vs. Time limiter (FOLD, FOLDMODE).
- Back EMF compensator (MBEMFCOMP).

## *Velocity Control*

- Digital velocity loop control (Velocity Mode - OPMODE 0 or 1) receiving serial (J), analog (ANIN), or I/O triggered commands (MISPEED1, MISPEED2, MISPEED3, IN1, IN2, IN3, IN1MODE, IN2MODE, IN3MODE).
- Velocity stepping and jogging capability (STEP, J).
- Serial control through stored commands triggered through the Configurable I/O (IN1, IN2, IN3, IN1MODE, IN2MODE, IN3MODE).
- Automatic control loop tuning through the auto-tune feature (TUNE).
- Configurable application and system speed limits (VLIM, VOSPD, VMAX).
- Advanced control algorithms (COMPMODE):
  1. Proportional-Integral (GV, GVI).
  2. Pseudo-Derivative with feed forward (KV, KVI, KVFR).
  3. Standard Pole Placement (BW, MJ, LMJR, TF).
  4. Extended Standard Pole Placement (BW, MJ, LMJR, TF).
- First- and second-order low pass filtering capability (FILTMODE, LPFHZ1, LPFHZ2, COMPFILT).
- Notch filtering capability (FILTMODE, NOTCHHZ, NOTCHBW).
- Bandwidths up to 400Hz.
- “On-the-fly” homing capability (HOMETYPE) in analog velocity mode (OPMODE 1) through either the Configurable Inputs or terminal.
- “On-the-fly” switching between velocity and current/torque control (IN1, IN2, IN3, IN1MODE, IN2MODE, IN3MODE).

## *Position Control*

- Serial positioning loop control (Position Mode - OPMODE 8 & PCMDMODE) receiving serial or I/O-controlled command (IN1, IN2, IN3, IN1MODE, IN2MODE, IN3MODE).
- Analog positioning loop control (Position Mode - OPMODE 8 & PCMDMODE) over a  $\pm 10$  V range with scaling capability (PSCALE, GEAR, GEARI, GEARO) and I/O triggering.
- Incremental and absolute positioning with an “in position” indicator (MI, MA, INPOS, PEINPOS).



- Simple absolute and incremental indexing with I/O triggering capability (MAPOS, MASPEED, MIDIST0, MIDIST1, MIDIST2, MIDIST3, MISPEED0, MISPEED1, MISPEED2, and MISPEED3) through either the serial port or the hardware configurable inputs (IN1, IN2, IN3, IN1MODE, IN2MODE, IN3MODE).
- Position homing with I/O triggering capability (MH, HOMESPD, HOMESTATE, HOMETYPE) through either the serial port or the configurable inputs (IN1, IN2, IN3, IN1MODE, IN2MODE, IN3MODE).
- Electronic Gearing (Position Mode - OPMODE 4) featuring pulse following or master encoder capability with resolution up to 3mhz through C8 connector (2.5khz through opto-isolators in C3) (GEAR, GEARMODE, GEARI, GEARO, PEXT, PEXTOFF, VEXT, XENCRES, XENCDIR). Homing capability is provided.
- Dual-loop mode (DUALFB) capable of positioning from a load feedback (C8 input, PEXTOFF, PEXT, VEXT, XENDIR) device while controlling velocity and torque from the motor feedback (C2 input).
- PID position loop tuning (GP, GPD, GPI, ) with feed-forward acceleration gain input to both the velocity and current loops (GPAFR, GPAFR2), and feed-forward velocity gain input to the velocity loop (GPVFR).
- Software position limits (PLIM, PMAX, PMIN, PEMAX).
- Configurable integrator dynamics through travel range (GPISATOUT, GPISATIN).
- Cumulative, revolution, and error position counters (PFB, HWPOS, PRD, PE).
- Position indicators (INPOS, PEINPOS, PE, PEMAX, PFB, PFBOff).

## ***Profile Ramping Control***

- Electronic Braking (STOPMODE, ISTOP).
- Separate ACCEL and DECEL linear ramping control in velocity and position mode (ACC, DEC, PROFMODE).
- S-curve ACCEL and DECEL ramping control (PROFSCRV, PROFMODE) in the position mode (OPMODE=8).
- Controlled decelerating (DECSTOP, DISSPEED, DISTIME) with acceleration feed-forward when the drive is left enabled (STOP, HOLD, CWLIM, CCWLM, LIMDIS) or becomes disabled (K, S, ACKFAULT, DIS). This feature can be used in conjunction with the Electronic Braking feature.
- Torque compensator for coulomb friction and weight counter-balancing (IFRIC, IGRAV).

## ***Motor Controllability***

- Provides linear and rotary motor control (MOTORTYPE, MPITCH, MENCRES) with automatic unit conversion.
- Configurable back EMF characteristics for effective current loop controller design and command (MBEMF, MBEMFCOMP).
- Danaher Motion Kollmorgen's patented Torque Angle control to maximize motor output power (MTANGLC, MTANGLP, MVANGLF, MVANGLH).
- Motor speed and current limits (MSPEED, MICON, MIPEAK).
- Thermal protection control (MFOLD, MFOLDD, MFOLDDIS, MFOLDR, MFOLDT) adaptable to any motor.
- Auto-configuration feature (ACONFIG, ACONFIGST, MFBDIR) automatically configures the motor's power and feedback cables. It checks, warns, and corrects for incorrect wiring of these cables.
- Configurable positive motion direction (DIR).

## ***Feedback Devices***

- Device zeroing mode that rotates the motor to an electrical null point (ZERO, IZERO).

## **RESOLVERS**

- Variety of motor and resolver pole combinations (MPOLES, MRESPOLES).
- Resolver-zero offsetting (MPHASE).
- System accuracy's better than 20 arc minutes (reduced when resolver pole count is increased).
- Inter-LSB interpolation between least significant bits (ILSBMODE) allows 18-bit velocity control and 16-bit positioning capability.
- Automatic resolution configuring, based on application speed requirements (RDRES, VMAX).

## ENCODERS

- Maximum frequencies to 3 MHz before quad.
- Up to 10 million counts per motor electrical cycle (MENCRES).
- Configures automatically (ENCINIT, ENCINITST, ENCSTART, IENCSTART).
- Index pulse offsetting capability (MENCOFF).
- Variety of encoder types (MENCTYPE):
  1. Encoder with or without index.
  2. Encoder-hall effects with or without index (MHINVA, MHINVB, MHINVC, HALLS).

## SINE ENCODERS

- 256x internal interpolation.
- Up to 128x encoder equivalent output (SININTOUT).
- Most standard encoder features mentioned above.

## *System Communications*

- Serial communications port (address setting through DIP switch on top of drive).
  1. RS-232 single and up to 31-axis multi-drop addressing (ADDR).
  2. RS-485 single and up to 31-axis multi-drop addressing (ADDR).
  3. Data transmission (DUMP, GET, LIST, MLIST, GETMODE) baud rates of 9600 or 19200.
  4. Configurable protocol (ECHO, PROMPT, ACKMODE, GETMODE, MSG).
  5. Interface through Danaher Motion Kollmorgen's **MOTIONLINK** or a dumb terminal.
- Differential analog input command (ANIN).
  1.  $\pm 10V$  at 14 bit resolution.
  2.  $\pm 10V$  at 15 bit resolution below 4V of input for slow speed operation using the Dual Gain feature (ANDG - SE units only).
  3. Input signal filtering (ANLPHZ).
  4. Flexible analog input scaling (VSCALE, ISCALE, ANOFF, ANZERO, ANDB).

- SERCOS interface communications port (SERCOS interface versions only).
  1. 2-msec update rate.
  2. Complete set of manufacturer's IDNs.
  3. **MOTIONLINK** communication through the serial port.
- Encoder Equivalent Output signal (C4 connector) eliminates the need for an additional position feedback device. The maximum frequency of this output is 3 MHz for standard encoders and 1.2 MHz for sine encoders.
  1. **Resolver-based systems:** developed through R/D hardware circuitry for minimal phase lag, it provides a before quad resolution of up to 16384 lines (65536 quad counts) per revolution of the motor shaft (dependant on motor speed). This signal resolution is configurable (ENCOUT). Index pulse can be varied as much as one complete revolution (INDEXPOS).
  2. **Encoder-based systems:** actual encoder signals are exported through this output (MENCRES) and can be scaled down by multiples of two (ENCOUTO).
  3. **Sine-encoder systems:** developed through the interpolator circuit (SININTOUT) and encoded to a quadrature signal. A frequency limiter (MSINFRQ) is provided with fault protection.

## ***MOTIONLINK Software Environment***

- Easy setup, commanding, and monitoring techniques.
- Contains an extensive database for many of Danaher Motion Kollmorgen's motor series.
- A backup screen that provides automatic loading of system parameters.
- Realtime metering of many system parameters.
- PC scope feature for profile recording and realtime motion performance measuring.
- Optional terminal mode feature for keystroke commanding and monitoring.
- Status screen indicating system operation and fault/error checking.
- Extensive on-line help file (F1) designed to assist you in **MOTIONLINK**'s intuitive nature.
- A set of limits folders allowing you to manipulate the position, velocity, current, and filtering limits from one screen.
- An I/O screen for easy manipulation of the drive's I/O, thermostat options, encoder output, and hardware position limits capabilities.

- A feedback device screen that provides realtime pictorial positioning information. It also includes a resolver zeroing routine and an encoder initialization folder.
- A tuning screen designed to allow you to adjust control loop gains quickly while visibly watching the affects on performance.
- A control loops screen that provides direct manipulation of velocity and position loop gain parameters.

## ***Monitoring and Troubleshooting Tools***

- Performance recording (RECDONE, RECING, RECOFF, RECORD, RECRDY, RECTRIG).
- System status checking (STAT, STATUS, STATUS2).
- Control loop monitoring:
  1. Current/torque (I, IA, IC, ICMD, IMAX, ICONT, DICONT, DIPEAK).
  2. Speed (V, VCMD, VE).
  3. Position (PCMD, PFB, PE, HALLS, HWPOS, INPOS, PRD, PEXT, PEINPOS).
- Analog output (ANOUT) with 12-bit resolution and scaling flexibility (PSCALE) that can be configured to monitor speed, torque, current, power, velocity error, following error, and position feedback (PFB). Should be used as a monitoring tool only.
- Dual-state digital output (O1, O1MODE, O1RST, O1TRIG) that toggles according to various absolute current, speed, and position parameter settings. Also can be used to communicate occurrences of fold-back, motor braking, and the status of the Remote Enable hardware switch.
- Status Display (TESTLED) indicator that communicates operational and fault characteristics.
- Realtime reading of the 10-position DIP switch (DIP, DIPEN).
- Software status switch indicator provided for configurable inputs (IN1, IN2, IN3, IN1MODE, IN2MODE, IN3MODE).

## ***Fault and Safety Detection***

- Watchdog faults.
- General faults (ACKFAULT, STAT, STATUS).
- Configurable under-volt protection (UVMODE, UVTIME, UVRECOVER).
- Speed and current protection (VOSPD, VLIM, ACC, DEC, ILIM, ILIM2).

- Fatal and non-fatal error coding with text explanation to the host (ERR, FLTHIST, FLTCLR). A run-time counter (TRUN) that records the time the error occurred is also provided.
- Configurable motor thermal protection that accepts various thermostat types (THERM, THERMODE, THERMTYPE, THERMTIME).
- Configurable drive thermal protection through the fold-back feature (FOLD, FOLDMODE). It sets the maximum time limit the drive can provide peak current (2:1 for Sx or 3:1 for Cx) to the motor.
- Configurable motor thermal protection through the motor fold-back feature (MFOLD, MFOLDD, MFOLDDIS, MFOLDR, MFOLDT). It sets the maximum time limit the drive can provide continuous current to the motor.
- Hardware position limit switch detection (CCWLIM, CWLIM, LIMDIS, IN1, IN2, IN3, IN1MODE, IN2MODE, IN3MODE).
- Configurable software position limits (PLIM, PMAX, PMIN, PEMAX).
- Configurable fault relay output (RELAY, RELAYMODE, DISTIME, IN1MODE, IN2MODE, IN3MODE).
- Active disable feature (ACKFAULT) that allows you to determine how the system should react at the occurrence of a fault. The system can immediately disable, where the motor will coast to a stop, or it can be programmed to a controlled decelerated stop (DECSTOP, DISSPEED, DISTIME, STOPMODE, ISTOP).
- Active enable indicator through the Status Display decimal (ACTIVE, DRIVEOK, SWEN, READY, REMOTE, DIPEN).

## *General*

- Many enabling and disabling features (K, S, STOP, REMOTE, EN, DIS).
- Flash firmware memory for easy field upgrade installation.
- Danaher Motion Kollmorgen's patented "Torque Angle Control" for buried magnet motor designs (MTANGLC, MTANGLP, MTANGLE, MTANGLH - defined as speed and torque optimization through commutation angle advancing of the drive's output current waveform with respect to the motor's back EMF waveform).
- Firmware and serial number information (VER, SERIALNO, MOTOR) via terminal.

## BUS Module

The SERVOSTAR family includes a variety of BUS Modules that convert a single-phase logic voltage and a three-phase AC line into the drive's DC logic power and main DC BUS.

### Features

- Converts single or three-phase AC main lines into a rectified DC BUS (check BUS Module Electrical Specifications table to verify specific BUS Module operation). The input consists of a 3 $\phi$  diode bridge and BUS capacitors. These capacitors help to minimize BUS ripple, and therefore, BUS drooping during the peak power demands of the load.
- All units have soft-start capability to minimize the effect of “in-rush” current spikes inherent in a power-up cycle. This feature eliminates the need for a costly isolation transformer.
- The logic BUS Module on all units consists of a SMPS to develop the required  $\pm 15$  V and +8 V from either the main line (use L<sub>A</sub> and L<sub>B</sub>) or a separate AC logic input. Most BUS Modules can source up to four standard drives (SRxx200 or SExx200). See AppNote ASU000H on the PSP CD-ROM for details on logic sourcing.
- Product features are:

Indicator	PA08	PA14/28	PA50/75/85
<sup>1</sup> Green LED	X	X	X
<sup>2</sup> Yellow LED	N/A	X	X
<sup>3</sup> Red LED	N/A	N/A	X
<sup>4</sup> Fault Relay	N/A	X	X
<sup>5</sup> SoftStart	X	X	X
<sup>6</sup> Regeneration	N/A	I/E	E

<sup>1</sup> Indicates when voltage is on the caps.

<sup>2</sup> Indicates unit is operating in regen and may flash during aggressive accelerations.

<sup>3</sup> Indicates unit is still in SoftStart. This LED is also used to indicate when an OverVoltage fault has occurred from too much power being pumped back into the system during regen.

<sup>4</sup> The relay is a normally-open contact and closes after the unit is powered-up and out of SoftStart. The contact opens if there is an improper BUS Module voltage (dropping in and out of SoftStart), an over-heated internal regen resistor, or the main heatsink becomes too hot.

<sup>5</sup> Contains SoftStart capability

<sup>6</sup> E-external, I-internal

- The PA-LM unit is a logic supply only and should be used in multi-axis applications where the number of drives exceed the logic capabilities of the BUS Module. This unit comes with three green LED's that verify the presence of the +15 V, -15 V, and 8 V sources.



*See the Bus Module Electrical Specifications for details on these features.*



# TROUBLESHOOTING

Technical papers and publications about the **SERVOSTAR** and its associated applications complete the information package necessary for you to become well versed with the product. Danaher Motion Kollmorgen's engineering and technical resource staffs have prepared these notes. The PSP CD-ROM contains technical content stored in an electronic .PDF format. You must have Adobe's Acrobat Reader (also available on the CD-ROM) installed on their computer to view and print these documents. This package is available on the CD-ROM. The most recent versions of all the material contained in this PSP (manual and CD-ROM) can be downloaded from Danaher Motion's website ([www.danahermotion.com](http://www.danahermotion.com)).

## Troubleshooting Tools

---

The **SERVOSTAR**'s **MOTIONLINK** package comes with a comprehensive monitoring and troubleshooting help set. For troubleshooting the drive, it provides a Status screen (click on "Status" button in the upper right-hand corner of Main **MOTIONLINK** screen). The Status screen allows you to check the drive enable switches, the Status Display LED, fault status with complete error history, and mode settings for several of the drive's protection features. If using the terminal mode, you can simply check the contents stored in the STATUS, FLTHIST, and ERR variables.

An additional help provided by **MOTIONLINK** is the I/O screen (click on "I/O" button on the side of the Main **MOTIONLINK** screen). The I/O screen gives you the ability to check the status of the hardware position limit switches, the motor thermostat, and the encoder equivalent output. It also allows you to set up the I/O on the C3 connector for a variety of troubleshooting and monitoring approaches.

For monitoring system performance, **MOTIONLINK** comes with a variety of monitoring tools. The customer can monitor a variety of variables from the Monitor screen (click "Monitor" button at the top of the Main **MOTIONLINK** screen) to compare up to three variables against themselves at one time. The Tune and Record screen allows you to evaluate the system's actual performance against a predefined command profile. Also from this screen, adjusting the gains until optimum following is achieved can vary the performance.

## Error Codes

---

In most cases, the SERVOSTAR communicates error codes with a text message via the serial port to the host. Some error codes are also transmitted to the Status Display. The same message is saved in the EEPROM under an error history log (FLTHIST, ERR) so that nothing is lost when power is removed. Not all errors reflect a message back to the host. In these cases, the no-message errors communicate to the Status Display only.

The response of the SERVOSTAR to an error depends on the error's severity. There are three levels of severity:

- 1) Warnings, simply called errors, are not considered faults and do not disable operation
- 2) Non-fatal errors, or simply faults, that disable the drive and indicate a fault status
- 3) Fatal errors, or fatal faults, that disable almost all drive functions (including communications)



***The drive is automatically disabled at the occurrence of a fault. Executing a drive disable command (DIS or K) followed by the EN command, or toggling the Remote Enable line (REMOTE) resets the fault latch, and if the fault condition is no longer present, re-enables the system.***

**FATAL FAULT ERROR CODES**

Status Display	Fault Message	Possible Cause	Err #
t	Power stage OverTemp	overload, fan malfunction, power stage failure	1
o	OverVoltage	excessive decel rate*	2
P	OverCurrent	power stage surge current*	3
r0	External feedback fault	Feedback signal through C8 not correctly detected	4.0
r1	Resolver line break	break in resolver feedback detected	4.1
r2	RDC error	fault in resolver-to-digital converted detected	4.2
r3	Sine Encoder init fail	sine encoder card has not initialized properly	4.3
r4	A/B line break	break in encoder A/B input lines detected	4.4
r5	Index line break	break in encoder index line	4.5
r6	Illegal halls	illegal hall combination detected	4.6
r7	C/D line break	break in sine encoder C/D line detected	4.7
r8	A/B out of range	sine encoder A/B level out of range	4.8
r9	Burst pulse overflow	sine encoder fault	4.9
r10	Endat Communication Fault	Serial communication to the Endat Encoder failed	
u	Under voltage	bus voltage is too low	5
H	Motor over temperature	motor overload caused overheating	6
A1	Positive analog supply fail	Failure in +12V supply (regulated)	7.1
A2	Negative analog supply fail	Failure in -12V supply (regulated)	7.2
J	OverSpeed	velocity $\geq$ VOSPD	8
J1	OverSpeed	Velocity $\geq$ 1.8 x VLIM	8.1
E	EEPROM failure	Faulty EEPROM	9
e	EEPROM checksum fail	EEPROM checksum invalid on power up*	10
F	Foldback	System in FoldBack mode	12
d5	Positive over travel fault	PFB exceeded PMAX with PLIM=1	14.1
d6	Negative over travel fault	PFB exceeded PMIN with PLIM=1	14.2
d1	Numeric position deviation	Internal fault	15.1
d2	Excessive position deviation	PE > PEMAX	15.2
c	Communication interface	A communications fault has occurred	16

\*These faults can only be cleared by cycling power

***NON-FATAL ERROR CODES***

<b>Error Message</b>	<b>Possible Cause</b>	<b>Err #</b>
No Error	no error was recorded	0
Unknown Command	Undefined command	20
Unknown Variable	undefined variable name	21
Checksum error	error on comm. message checksum (ACKMODE 2)	22
Drive Active	drive needs to be inactive for the requested command or variable	23
Drive Inactive	drive needs to be active for the requested command or variable	24
Value out of range	variable value out of range	25
Negative Number	variable must be $\geq 0$	26
Not in proper Opmode	not in correct Opmode for specified command	27
Syntax Error	communication message syntax error	28
Tune Failed	auto tuning failed	33
Bad Bandwidth	AutoTuning BW is out of range	34
Bad Stability	bad stability	35
Not programmable	variable is read-only	36
Current loop design failed	CONFIG failed due to current loop design failure	37.01
MENCRES out of range	CONFIG failed due to MENCRES	37.02
MENCOFF out of range	CONFIG failed due to MENCOFF	37.03
MSPEED out of range	CONFIG failed due to MSPEED	37.04
MBEMF out of range	CONFIG failed due to MBEMF	37.05
MJ out of range	CONFIG failed due to MJ	37.06
ACC out of range	CONFIG failed due to ACC	37.07
DEC out of range	CONFIG failed due to DEC	37.08
DECSTOP out of range	CONFIG failed due to DECSTOP	37.09
VLIM out of range	CONFIG failed due to VLIM	37.10
VOSPD out of range	CONFIG failed due to VOSPD	37.11
VSCALE out of range	CONFIG failed due to VSCALE	37.12
OITRIG out of range	CONFIG failed due to OITRIG	37.13
OIRST out of range	CONFIG failed due to OIRST	37.14
DISSPEED out of range	CONFIG failed due to DISSPEED	37.15
MENCTYPE out of range	CONFIG failed due to MENCTYPE	37.16
Communication error	Error at physical comm. layer	38
Not in proper COMPMODE	The REFRESH command was given with COMPMODE $\neq 3$	39
EXT velocity param warning	D, H, R parameters for COMP-MODE 3 do not have the proper relationship to each other.	40
Vel loop design failed	The velocity loop can't be con-figured with given parameters	41
Invalid EEPROM	The EEPROM test failed	42
Recording active	The requested command cannot be executed because it conflicts with a recording in progress	43
Rec data not available	No data are available for the GET command	44
EEPROM is empty	Data cannot be loaded because the EEPROM is empty	45
Argument must be binary	Variable argument must be a power of 2	46

Error Message	Possible Cause	Err #
Burnin is active	The requested function cannot be executed during Burnin (a factory function)	47
Burnin is not active	Burnin (factory function) cannot be stopped if it is not active	48
Conflicts with ENCOUT	The requested value for VLIM conflicts with ENCOUT.	49
Conflicts with VLIM	The requested value for ENCOUT conflicts with VLIM.	50
Not available	The requested variable value is not available; refer to the description of the variable in section 1 to determine why.	51
Drive is in Hold mode	Motion was requested with the drive in Hold mode	52
Limit Switch Hold	Drive is in Hold mode due to limit switch being tripped	53
Command Into Limit	Requested motion is in direction of tripped limit switch	54
Drive is in Zero Mode	Motion requested while in Zero mode	55
Motor is Jogging	Tune cmd cannot be executed because motor is jogging	56
Argument not divisible by 20	Argument must be a multiple of 20 to be accepted	57
Encoder Initialization Process Active	A command cannot be executed because it has been requested while the encoder initialization process is active	58
Tune failed-no rotation	Tune cmd failed because motor could not rotate	60
Tune failed-current sat	Tune cmd failed because the current loop saturated	62,66 70,74
Tune failed-no vel design	Tune cmd failed because the vel loop could not be designed	63,67 71,75
Disable During Tune	Tune cmd failed because drive was disabled while tuning	76
Hold During Tune	Tune cmd failed because drive entered Hold mode while tuning	77
Low Velocity Limits	Tune cmd failed because VLIM is too low	78
Use Lower Bandwidth	Tune cmd requires a lower bandwidth in order to execute	79
Drive in Dual Feedback mode	Command cannot be accepted because dual feedback is active	80
Drive is in Gear mode	Command cannot be accepted because drive is in gear mode	81
Functionality is occupied	Selected INxMODE function is already assigned to another INxMODE	82
Warning: A/B Line not routed	Selected GEARMODE requires A/B inputs to be routed using INxMODE 5 and 6.	83
Warning: Limit sw not routed	Limit switches must be routed using INxMODE 1 and 2.	84
Move is pending	The last ordered move command has not been completed yet.	85
Incorrect password	The password entered was incorrect	90

Error Message	Possible Cause	Err #
Password protected	The command or variable requested is password protected and intended for factory use only	91
Capture during homing	A position capture occurred during homing	92
Homing during capture	A homing request was made during position capture	93
Capture process not done	The requested command can't be processed due to pos capture not being complete	94
Capture process not active	The requested command can't be processed due to pos capture not being active	95
Capture process not enabled	Position capture cannot be executed	96
ENCSTART while ACONFIG		97
SERCOSinterface test failure		999

## ***NO MESSAGE FAULTS***

Display	Fault Description	Fatal	Non-Fatal	Flashing Display	Steady Display
≡	Watchdog (DSP)	✓		✓	
≡	Watchdog (HPC)	✓			✓
-1	No Compensation	✓		✓	
-2	Invalid Velocity Control	✓		✓	
-3	Encoder not Initialized on attempt to enable	✓		✓	
-4	Encoder Initialization failure	✓		✓	
-5	AutoConfig failure	✓		✓	
L 1	Hardware CW limit switch open		✓	✓	
L 2	Hardware CCW limit switch open		✓	✓	
L 3	Hardware CW and CCW limit switches open		✓	✓	
L 4	Software CW limit switch is tripped (PFB>PMAX & PLIM=2)		✓	✓	
L 5	Software CCW limit switch is tripped (PFB<PMIN & PLIM=2)		✓	✓	
A 3	Positive and negative analog supply fail	✓		✓	
l	RAM failure (during init)	✓			✓
c	EPROM checksum (during init)	✓			✓
E101	Altera load failure (during init)			✓	
E102	Altera DPRAM failure (during init)			✓	
E103	DSP load fail (during init)			✓	
E104	DSP alive failure (during init)			✓	
8	Test LED			✓	
B	Indexed position with zero velocity			✓	

---

## Fault Monitoring System

---

The SERVOSTAR's microprocessor is constantly monitoring the status of many different components. In general, the philosophy of the SERVOSTAR is to latch all fault conditions so you can readily determine the source of the problem. When a fault is detected, it is logged in the internal error log, indicated in the Status Display, enunciated over the serial port, and in most conditions causes a drive disable. Many faults can be reset by toggling the hardware remote enable (REMOTE input).

The following provides a list of some of the more frequent faults the drive may detect in the unit hardware and operating system.

- **Motor OverTemperature:** The Motor's External Thermostat input is monitored for an open circuit condition. You can define (using THERMODE) what happens under this fault condition. The worst case event is a power stage disable when an 'H' appears in the status display, and the fault relay contacts (RELAY) are open.
- **Hardware Position Limit Inputs:** The IN1, IN2, IN3 Inputs are constantly monitored. If INxMODE set these inputs for CW/CCW hardware position limits, they are monitored for an open-circuit condition. Although not necessarily an error condition, motor operation can be affected by these inputs. The SERVOSTAR can ignore the hardware position limits if you set LIMDIS = 1. The worst case event is that further motion in the given direction is not allowed with an 'L' illuminated in the status display. If both CW and CCW position limit inputs have detected an open-circuit condition, the SERVOSTAR enters into Hold position state (HOLD = 1).
- **Drive OverTemperature:** The internal heatsink temperature is monitored for an unsafe condition. This condition causes a 't' to be displayed and disables the drive. The drive will eventually cool enough to allow reset of this condition.
- **RMS OverCurrent (FoldBack):** The FoldBack detection system can 'clamp' the available output current. This is not a true fault condition, but may cause undesired performance, due to the command current being limited below what is required to achieve the desired performance. This condition is indicated with a flashing 'F' in the status display and can be detected by monitoring the FOLD switch variable.

- **Bus OverVoltage:** An over-voltage condition shuts down the drive and displays a lower-case 'o' in the status display. This fault will occur mostly during regen operation where the BUS is raised to higher values than that produced by the power supply.
- **Bus UnderVoltage:** An under-voltage condition shuts down the drive and displays an 'u' in the status display. This fault normally occurs when the incoming line voltage drops out or a fault occurs in the power supply.
- **PowerStage Fault (OverCurrent):** Hardware circuitry monitors load short-circuit, transistor failure, and instantaneous OverCurrent. In general, toggling the Remote Enable cannot reset a power stage fault. Power must be cycled. A flashing 'P' in the status display indicates this condition.
- **Feedback Loss:** Hardware is used to detect a wire-break condition in encoder based systems or the presence of the Sine and Cosine resolver feedback signals in resolver based systems. The SERVOSTAR disables and displays an 'r' in the status display when either of these signals are not present.
- **Low-voltage power supply faults:** Out of tolerance values on the  $\pm 12$  VDC analog supplies will cause an 'A' to be displayed and cause the drive disable.
- **OverSpeed fault:** Software continuously monitors the actual (feedback) speed. If the motor speed exceeds the VOSPD limit, a 'J' will be displayed and the drive will be disabled. This normally occurs when there is an improperly tuned system and the load overshoots its commanded speed.
- **No compensator:** In case the SERVOSTAR cannot design a compensator, such as after a RSTVAR command, CLREEPROM, or any change in the motor or drive parameters, a flashing minus sign (-) will be displayed and will cause the drive to disable. This display normally indicates that the drive does not have a compensation file loaded.



- **Memory reliability:** During the initialization process upon power up, the run time, variables memory (RAM - Random Access Memory), and the program memory (EPROM - Electrically Programmable Read Only Memory) are tested.  
If a RAM fault is detected, an 'I' is displayed and the drive is halted. If an EPROM fault is detected, a 'c' is displayed and the drive is halted.  
The non-volatile memory (EEPROM) is also checked for integrity upon power-up. Any discrepancy in this data is noted with an 'e' in the status display. After power-up is successfully completed, any subsequent fault in the operation of the EEPROM is noted with an 'E' in the status display.
- **WatchDogs:** In addition, the SERVOSTAR incorporates a watchdog system to maintain software operation integrity. Failure of the watchdog mechanism will display three bars on the status display and cause the drive to halt. This normally indicates serious problems. Please contact the factory for support.

## Firmware Upgrades

---

From time to time, Danaher Motion Kollmorgen adds features to its products that expand their overall capabilities. Features added to the SERVOSTAR can be easily implemented at the customer's site. This is accomplished by downloading new firmware via the drive's serial port directly from a host computer.

The customer ordering a firmware upgrade receives a file labeled "UPGRADE.EXE". Click on this file and a Windows program will prompt you to choose an unzipping method, baud rate, and communications port. If the baud rate and communications port selection is incorrect or the drive is set up for MultiDrop communications, then a DOS screen will pop up indicating an error has occurred. Simply close the window and select another baud rate and/or communications port.

**NOTICE:**

*Be sure to check the "Type" specifier on your unit. If your unit has the following label:*



*It requires firmware version 4.0.0 or higher. Other types will work with all firmware versions.*



*Firmware version 4.0.0 and higher is not compatible with the older versions of IGNITE (firmware loading software). Attempting to load incompatible firmware will result in the IGNITE program generating an error.*

To obtain the latest firmware version or receive additional help, contact Danaher Motion Customer Support ([www.danahermotion.com](http://www.danahermotion.com)).

## APPENDIX A

### Motor Pinouts

The SERVOSTAR S and SERVOSTAR CD product families can be mated with a variety of motors. Cable sets (motor and feedback) can be purchased directly from Danaher Motion Kollmorgen; which gives you a complete plug-n-play system. However, you may find it necessary to manufacture your own cable sets. This Appendix provides pinout information between the drive's power and feedback connections and the motor receptacles for most of Danaher Motion Kollmorgen's motor products.

#### *Motor Power Connections*

SERVOSTAR	GOLDLINE B, M, EB & XT			DDR	
DRIVE CONNECTIONS	B/M/EB Motor Receptacle	XT Motor Receptacle	WIRE Color (Winding to Receptacle)	Motor Receptacle	Wire Color (Winding to Receptacle)
MA	Pin A	3	Brown	Pin 3	Black
MB	Pin B	4	Red	Pin 4	Red
MC	Pin C	1	White	Pin 1	White
GND	Pin D	2	Green/Yellow	Pin 2	Green

SERVOSTAR	SILVERLINE		RBHR/RBE(H)
DRIVE CONNECTIONS	Motor Receptacle	Wire Color (Winding to Receptacle)	Wire Color
MA	Pin 1	Red	Red
MB	Pin 2	White	White
MC	Pin 6	Black	Black
GND	Pin 7	Green	

***SR/CR RESOLVER Connection***

<b>SERVOSTAR</b>	<b>GOLDLINE B, M, EB, XT</b>			
<b>C2</b>	<b>B/M/EB</b>	<b>XT 50X &amp; 70X</b>	<b>XT 30X</b>	<b>Wire Color (from resolver to motor receptacle)</b>
Pin 1	Pin A	Pin A	Pin 3	Black
Pin 2	Pin B	Pin B	Pin 7	Red
Pin 3 (shield)				
Pin 4	Pin D	Pin D	Pin 8	Yellow
Pin 5	Pin C	Pin C	Pin 4	Blue
Pin 6 (Shield )				
Pin 14 (Shield )				
Pin 15	Pin F	Pin F	Pin 5	Yellow/White
Pin 16	Pin E	Pin E	Pin 9	Red/White
Pin 13	Pin T	Pin R	Pin 2	Yellow
Pin 25	Pin U	Pin S	Pin 6	Yellow
Pin 12 (Shield )				

<b>SERVOSTAR</b>	<b>DDR</b>		<b>RBHR</b>
<b>C2</b>	<b>Resolver Connector</b>	<b>Wire Color (from resolver to motor receptacle)</b>	<b>Wire Color</b>
Pin 1	Pin 3	Black	Yellow
Pin 2	Pin 7	Red	Blue
Pin 3 (shield)			
Pin 4	Pin 8	Yellow	Red
Pin 5	Pin 4	Blue	Black
Pin 6 (Shield )			
Pin 14 (Shield )			
Pin 15	Pin 5	Yellow/White	Red / White
Pin 16	Pin 9	Red/White	Yellow / White
Pin 13	Pin 2	Blue	
Pin 25	Pin 6	Red	
Pin 12 (Shield )			

***SE/CE Encoder Connection***

SERVOSTAR	GOLDLINE B, M, EB & XT			
C2	Encoder Receptacle			Wire Color (at Motor Receptacle)
	B, M, EB Series MS threaded	XT Series MS Threaded	XT Series Euro Style	
Pin 1	Pin A	Pin A	Pin 1	Blue
Pin 2	Pin M	Pin M	Pin 2	Blue / Black
Pin 3 (shield)				
Pin 4	Pin B	Pin B	Pin 3	Green
Pin 5	Pin C	Pin C	Pin 4	Green / Black
Pin 6 (Shield)				
Pin 7 & 8	Pin S	Pin S	Pin 7	Red
Pin 9	Pin F	Pin F	Pin 17	Brown
Pin 10	Pin H	Pin H	Pin 16	Gray
Pin 11	Pin K	Pin K	Pin 15	White
Pin 12 (Shield)				
Pin 13	Pin T	Pin T	Pin 8	Yellow
Pin 14 (Shield)				
Pin 15	Pin D	Pin D	Pin 5	Violet
Pin 16	Pin E	Pin E	Pin 6	Violet / Black
Pin 18,19 & 20	Pin R	Pin R	Pin 10	Black
Pin 22	Pin G	( see note 1 )	( see note 1 )	( see note 1 )
Pin 23	Pin J	( see note 1 )	( see note 1 )	( see note 1 )
Pin 24	Pin L	( see note 1 )	( see note 1 )	( see note 1 )
Pin 25	Pin U	Pin U	Pin 9	Yellow

NOTE 1. Must be shorted to C 2 pin 18 for proper operation

SERVOSTAR	SILVERLINE		RBE(H)
C2	0802 Encoder Receptacle	0802 Wire Color	Encoder Receptacle
Pin 1	Pin 3	Blue	Pin 6
Pin 2	Pin 6	Blue / Black	Pin 5
Pin 3 (shield)			
Pin 4	Pin 4	Green	Pin 8
Pin 5	Pin 7	Green / Black	pin 7
Pin 6 (Shield )			
Pin 7 & 8	Pin 10	Red	Pin 2
Pin 9	Pin 12	Brown	
Pin 10	Pin 13	Gray	
Pin 11	Pin 14	White	
Pin 12 (Shield )			
Pin 13	Pin 1	Yellow	
Pin 14 (Shield )			
Pin 15	Pin 5	Violet	Pin 10
Pin 16	Pin 8	Violet / Black	Pin 9
Pin 18,19 & 20	Pin 9	Black	Pin 3
Pin 22	( see note 1 )	( see note 1 )	( see note 1 )
Pin 23	( see note 1 )	( see note 1 )	( see note 1 )
Pin 24	( see note 1 )	( see note 1 )	( see note 1 )
Pin 25	Pin 2	Yellow	

NOTE 1. Must be shorted to C 2 pin 18 for proper operation

## PLATINUM XT Motor Connection

When running the SERVOSTAR amplifier with a **PLATINUM XT** brushless motor, additional inductance is required between the amplifier and motor. Danaher Motion Kollmorgen offers the IP-10/30 inductor module rated at 900  $\mu\text{H}$ .

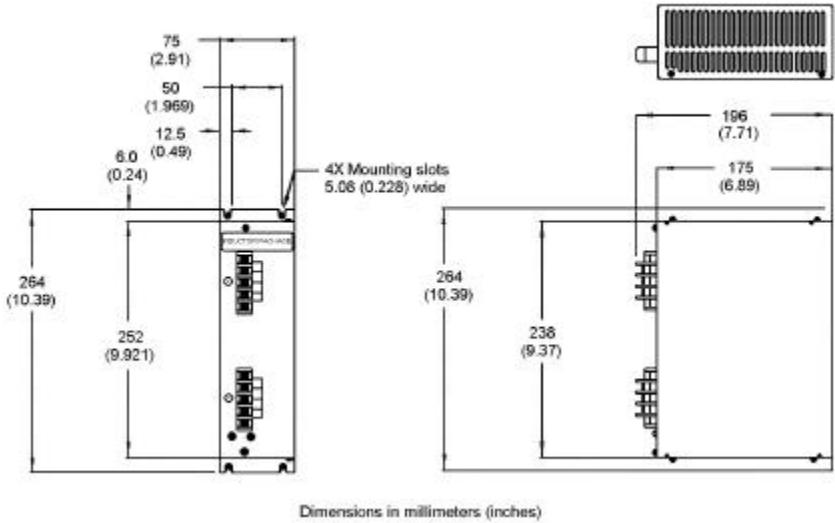

# System Connection Diagram

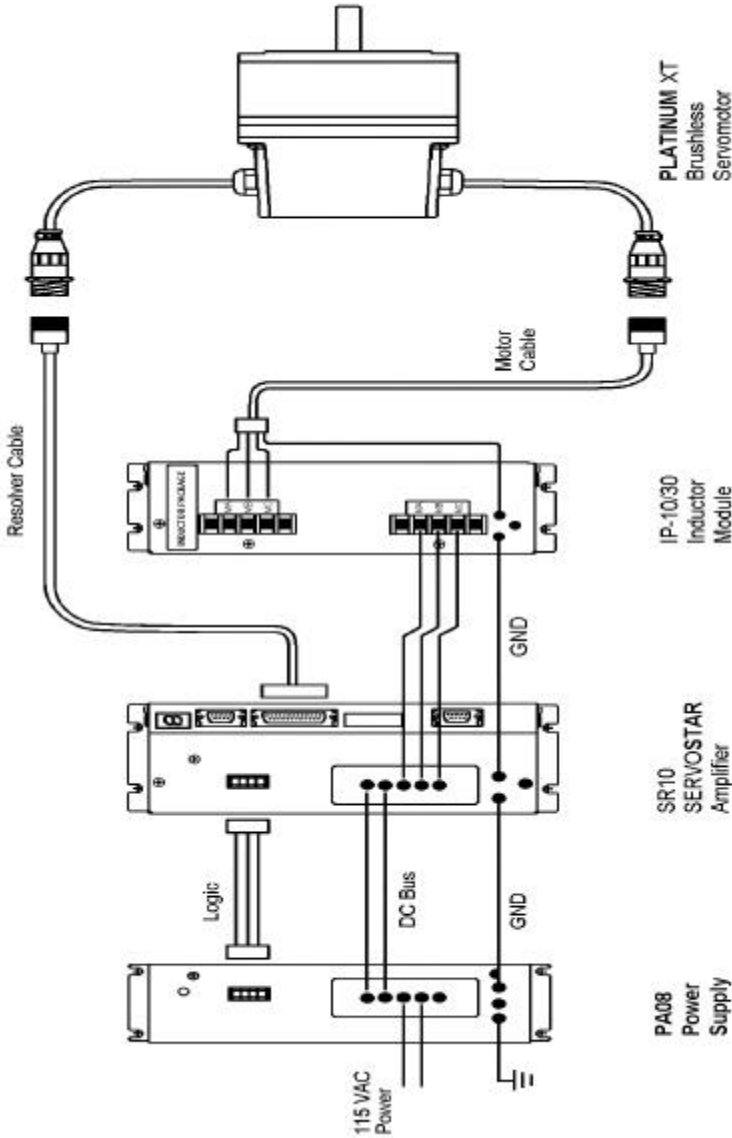



## APPENDIX B

### Programmable Positioning

---

Configurable Inputs trigger a higher level of programming capability than the SERVOSTAR S and SERVOSTAR CD-Series can offer through its buffer memory. Designed to be a compact and low cost solution, the BJP and SERVOSTAR system provides full programmable servo performance for many single and multi-axis applications.

This Appendix provides system wiring diagrams to specifically interface with the SERVOSTAR system. For a detailed explanation of the BJP's operation, refer to the *BJP Series Positioners Publication*, *BJP Installation Manual*, *BJx User's Manual*, and **MOTIONLINK** Plus Software Interface located on the PSP CD-ROM:

#### *Installation*

For system setup, you will need to interface with the SERVOSTAR drive through **MOTIONLINK**. Once communication is established, select the analog torque mode of operation (OPMODE 3). Connect the BJP to the drive:

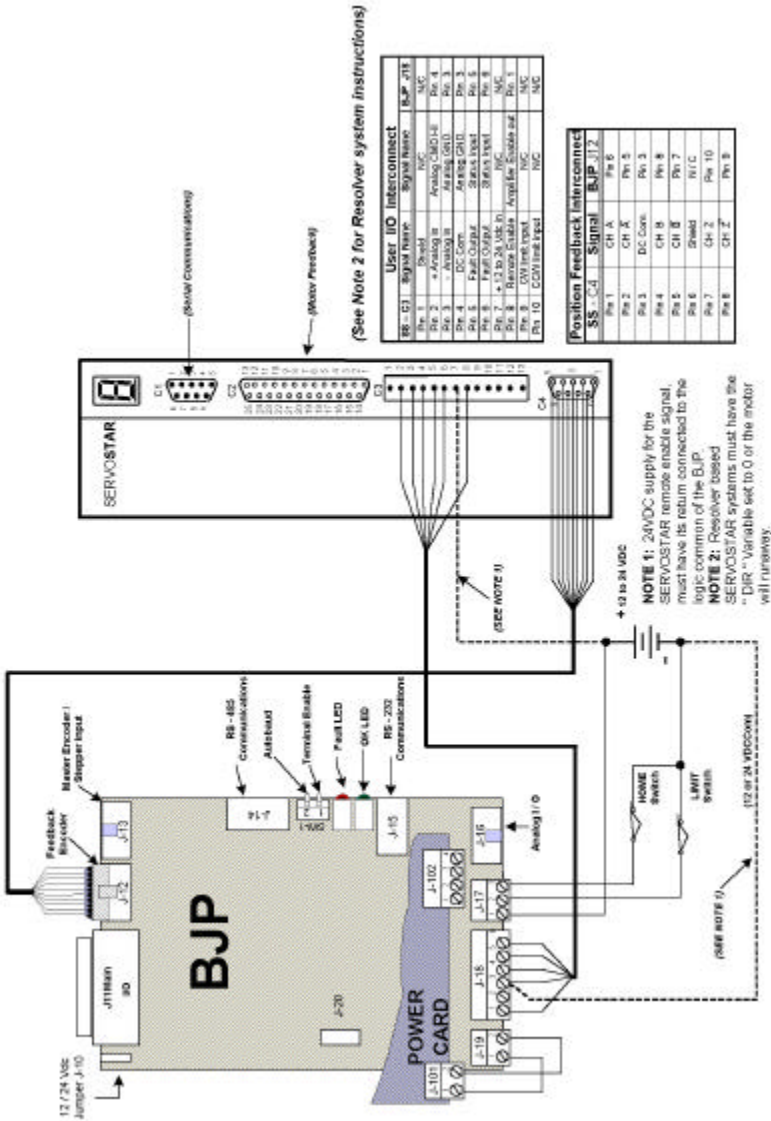

Verify that the SERVOSTAR motor direction variable (DIR) is set to zero. Otherwise, the motor runs away when controlled by the BJP.

The BJP uses a slightly different interface called "**MOTIONLINK Plus.**" Install this package from the PSP CD-ROM. Once proper connection is completed and communication is established through the BJP, refer to the *User's Manual* for programming instructions.

The figure below shows the external interface to the BJP. Reference the *User's Manual* for detail explanations.

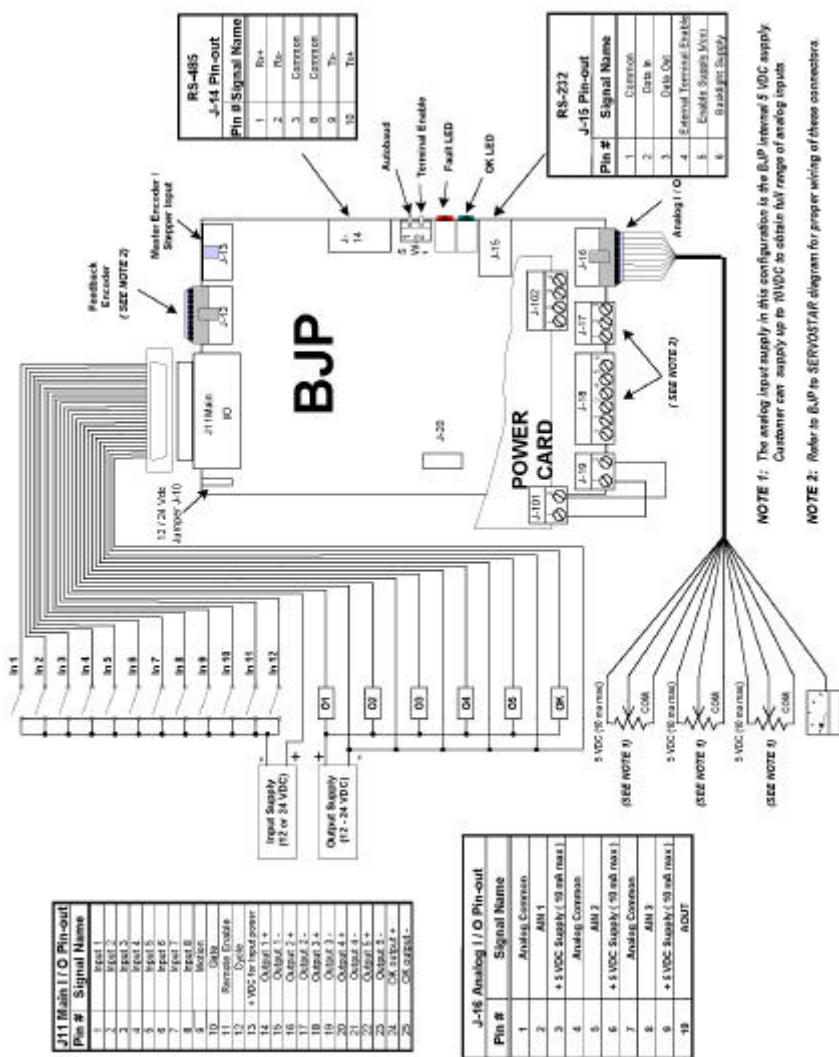

## APPENDIX C

### Digital Incremental Encoder Types

The SERVOSTAR products include models designed for use with incremental digital encoders. Encoders are available in different configurations from a variety of manufacturers using different nomenclature and conventions, making this topic somewhat confusing. Encoders can be as simple as having only A and B output channels or as complex as 6 channels of outputs. The SERVOSTAR supports many of these variants using the variable, MENCTYPE. The variable is set according to the features of the encoder. This document explains the different applications of the various MENCTYPES. A basic understanding of encoders is valuable for this discussion.

#### *Encoder Basics: A Review*

Encoders used with the SERVOSTAR provide incremental motor position information via two channels, referred to as the A Channel and B Channel. These channels output pulses for a unit of shaft motion. These pulses are typically generated within the encoder, using an optical disk that is directly connected to the motor shaft. The disk has etchings that either transmit or block light passing through the disk. An optical transmitter and receiver are on either side of the disk. The rotation of the disc (and motor shaft) interrupts light transmission from source to receiver, creating the pulses. The interruptions on the disk are called lines and result in the encoder ratings of lines-per-revolution (LPR) or pulses-per-revolution (PPR). The two channels provide the same information (pulses-per-unit of motion), but have a phase shift of 90° between each other as shown in the figure below.

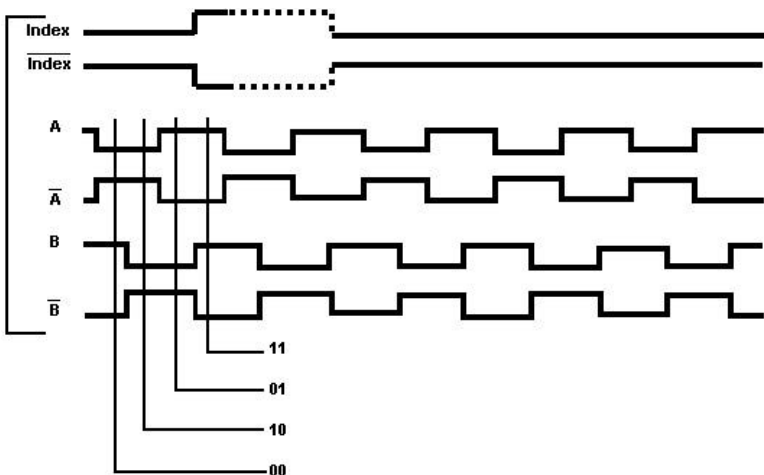

The 90° electrical phase shift between the two channels is referred to as "quadrature-encoded." The encoder output appears as a frequency, but the pulse rate is dependent on the motor's rotational velocity, not time. Since the two channels are phase-shifted by 90°, there are actually four states available per electrical cycle of these signals. The SERVOSTAR is able to receive four counts for position feedback for one line of motion of the encoder. The actual decode of the four position counts-per-line of the encoder is called "quadrature decode."

Additionally, since the encoder signals A and B are phase shifted by 90°, it is easy to design electronics that recognize whether A came before B or B came before A, thus supplying directional information. Encoders are often provided with an additional channel called a "Marker" channel, Zero Pulse, or an "Index" channel - different names for the same function. This channel outputs one pulse per revolution and is typically an extremely narrow pulse equating to roughly  $\frac{1}{4}$  of the width of an A or B channel pulse but can be wider. This is a reference position marker used for homing (absolute position reference) and commutation alignment.

One challenge when using encoders is that they are incremental rather than absolute devices. When using an absolute device (such as a resolver) to determine the motor shaft position within the rotation, the transmitted code is unambiguous. In other words, at power-up, the system knows the position of the motor shaft.

Incremental encoders only detects how far the motor shaft has moved from its original position. This presents a problem with three-phase brushless motors in terms of commutation alignment. Generally, it is extremely important to establish the appropriate commutation angle within the controller. (Commutation refers to the alignment of the electromagnetic field armature winding to the permanent magnet fields to create optimal torque.)

For this reason, encoders or motors are often provided with additional channels sometimes called "commutation tracks" or "Hall emulation tracks" which provide 1-part-in-6 absolute position information as shown in the following figure.

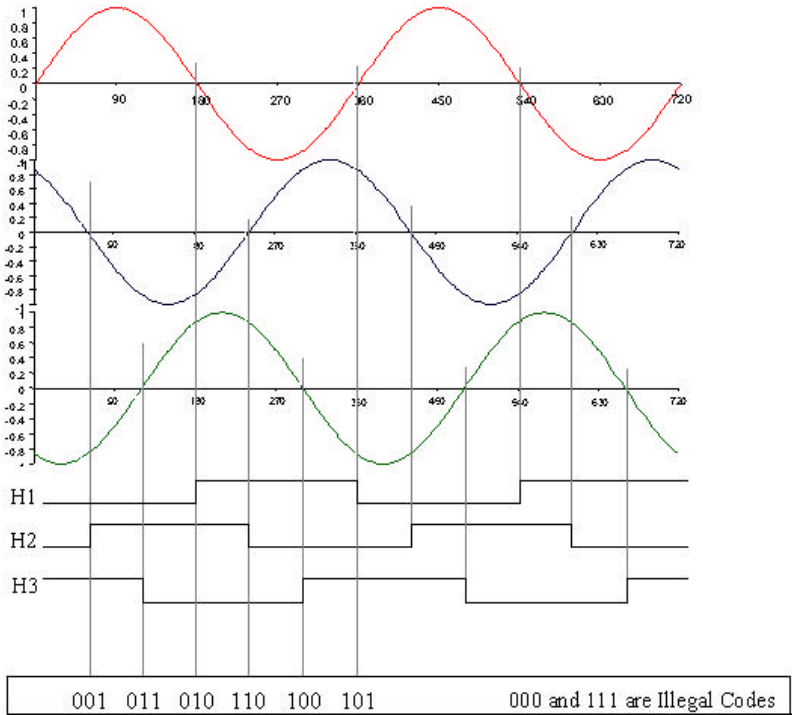

The hall channels can be synthesized in the encoder or can be discrete devices integrated in the motor windings. Commutation tracks (hall channels) provide three digital channels that represent alignment to the A-phase, B-phase, and C-phase back EMF of the motor. An encoder with Hall channels must have the correct output for the given pole count of the motor as the Hall signals are referencing the motor's BEMF waveform.



*Some systems use only hall channels for motor feedback data. The channels provide enough information to commutate a motor in an ON and OFF (trapezoidal) format but do not provide enough information to properly commutate a motor using sinusoidal control. Further, the coarse data is insufficient to control velocity below a few hundred RPM. The SERVOSTAR product is a high-performance controller and does not support hall-only operation.*

Since encoders are incremental devices, a loss or gain of a pulse creates system errors. Electrical noise is the single biggest factor in miss-counts. Transmitting the signals differentially provides the largest margin of noise rejection and the best signal fidelity. The **SERVOSTAR** is designed to receive only differential signals. Some "less expensive" encoders provide TTL or "Open Collector" signals. These are not compatible with the **SERVOSTAR**.

## ***SERVOSTAR Encoder Types***

The idea of obtaining velocity or position information from the series of pulses generated from the encoder is not difficult to understand. Permanent magnet brushless DC servo motors require commutation. As stated earlier, commutation is simply the positioning of the electromagnetic fields in alignment with the permanent magnet fields such that optimal torque is produced. This requires that the motor shaft position be known at all times. The use of incremental encoders requires some form of initialization to determine this motor shaft position at power up. It is this commutation initialization process that can lead to confusion.

Since the **SERVOSTAR** supports operation with many encoder types, it must be told which signals to expect to see and which initialization algorithm to perform. This is the purpose of the **MENCTYPE** variable. The following section explains the **MENCTYPE** variable and its setting for each encoder type. The next figure shows the initialization flow chart for the various **MENCTYPE**s.



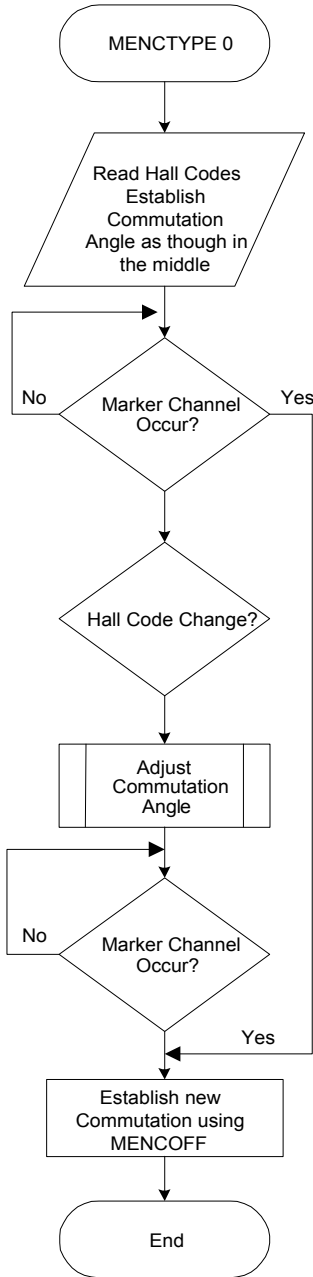

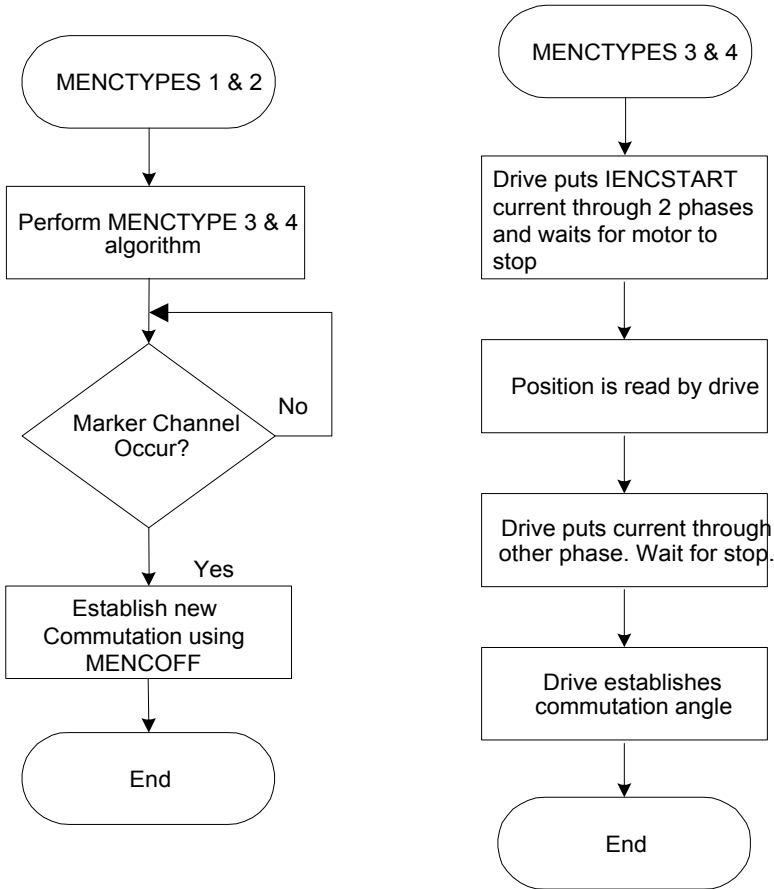

## MENCTYPE 0

***Incremental with A/B/I and Hall Channels*** MENCTYPE 0 is the most robust encoder system. The drive expects the signals as feedback from the motor. The hall channels is synthesized either in the encoder or discrete devices (Hall sensors) integrated in the motor windings. On power-up, the hall effect channels are read and a code is sent to the microprocessor to give it a coarse position for the motor. This position is accurate to within  $\pm 30$  electrical degrees of the optimal commutation angle. The SERVOSTAR assumes the actual motor position is half-way between the hall code settings for a maximum commutation error of  $\pm 30$  electrical degrees. Even with this amount of error, the motor is capable of producing torque with 86% efficiency. As the motor rotates, the first hall boundaries quickly traverse, providing the SERVOSTAR with information to better establish commutation angle. The SERVOSTAR corrects the commutation angle after it sees the marker pulse, according to the MECNOFF value.

## MENCTYPE 1

***Encoders with A/B/I channels*** Some systems do not have hall channels, so this mode tells the SERVOSTAR not to expect them. The initialization process occurs in two steps. The first step is the 'wake-and-shake initialization process (see MENCTYPE 3 and MENCTYPE 4 for "wake and shake" details) which gets the commutation alignment initialized after power up. The second step occurs when the index pulse is seen. Then, the SERVOSTAR aligns the commutation angle according to the setting of MECNOFF. MENCTYPE 1 initialization begins only when commanded through the serial port by using the ENCSTART command.



*The 'wake and shake' initialization process is not required if the marker location can be traversed without requiring the SERVOSTAR to move the motor to traverse the marker.*

## MENCTYPE 2

**Encoders with A/B/I channels** Some systems do not have hall channels, so this mode tells the **SERVOSTAR** not to expect them. The initialization process occurs in two steps. The first step is the 'wake-and-shake' initialization process (see MENCTYPE 3 and MENCTYPE 4 for "wake and shake" details) which gets the commutation alignment initialized after power up. The second step occurs when the index pulse is seen. Then, the **SERVOSTAR** aligns the commutation angle according to the setting of MECNOFF. MENCTYPE 2 is initialized using ENCSTART or performed automatically upon power-up when the drive is enabled.



*The 'wake and shake' initialization process is not required if the marker location can be traversed without requiring the **SERVOSTAR** to move the motor to traverse the marker.*

## MENCTYPE 3

**Encoders with A and B channels only** The simplest of encoders provide only an A and B Channel. MENCTYPE 3 configures the **SERVOSTAR** for these signals. These encoders provide no power-up information about where the motor is positioned, so this information is obtained through a special initialization process known as 'wake and shake'. When using MENCTYPE 3, initialization is required but it is triggered by the serial command, ENCSTART.

During the initialization process, "wake and shake," the **SERVOSTAR** puts current through two phases of the motor causing the motor shaft to rotate into a "torque detent." The magnets simply align the motor shaft to a position the **SERVOSTAR** understands. The motor is then rotated to the next pole position by energizing the windings in a slightly different manner. The **SERVOSTAR** then has enough information to establish an appropriate commutation angle using the number of motor poles (MPOLES) and the number of counts for the encoder (MENCRES).

This method of initialization has the advantage of allowing an extremely cost-effective feedback device. However, the requirement to pull the motor into these torque detents is subject to outside influences (such as friction) and can prevent the motor motion from occurring very effectively or even at all! Additionally, large inertia loads can overshoot and oscillate during this pull-in position, giving the microprocessor false readings. These MENCTYPEs are best for systems with specific criteria requirements such as low friction, low cost, and low inertial loads. The amount of electrical current used in this initialization mode is adjustable using the IENCSTART variable and may need to be adjusted to optimize performance for large inertial loads.

## MENCTYPE 4

**Encoders with A and B channels only** The simplest of encoders provide only an A and B Channel. MENCTYPE 4 configures the SERVOSTAR for these signals. These encoders provide no power-up information about where the motor is positioned, so this information is obtained through a special initialization process known as 'wake and shake'. When using MENCTYPE 4, the process for initialization is automatically triggered on power-up when the drive is enabled or by using ENCSTART.

During the initialization process, "wake and shake," the SERVOSTAR puts current through two phases of the motor causing the motor shaft to rotate into a "torque detent." The magnets simply align the motor shaft to a position the SERVOSTAR understands. The motor is then rotated to the next pole position by energizing the windings in a slightly different manner. The SERVOSTAR then has enough information to establish an appropriate commutation angle using the number of motor poles (MPOLES) and the number of counts for the encoder (MENCRES).

This method of initialization has the advantage of allowing an extremely cost-effective feedback device. However, the requirement to pull the motor into these torque detents is subject to outside influences (such as friction) and can prevent the motor motion from occurring very effectively or even at all! Additionally, large inertia loads can overshoot and oscillate during this pull-in position, giving the microprocessor false readings. These MENCTYPEs are best for systems with specific criteria requirements such as low friction, low cost, and low inertial loads. The amount of electrical current used in this initialization mode is adjustable using the IENCSTART variable and may need to be adjusted to optimize performance for large inertial loads.

## MENCTYPE 5

*Not supported*

## MENCTYPE 6

**Incremental with A/B and Hall Channels** MENCTYPE 6 supports encoders as described in MENCTYPE 0, but lacking the marker or index channel. This device is selected using MENCTYPE 6 and follows the same process used in MENCTYPE 0 with the exception of the final search for the marker pulse. The system establishes the commutation angle based on the Hall effect edge. MENCTYPE 6 is most commonly used with linear motors.

## ***Commutation Accuracy***

The accuracy of the commutation alignment within the drive affects the overall system efficiency. Misalignment also causes greater torque ripple. As a general estimator, the following equation holds:

$$K_{t \text{ effective}} = K_{t \text{ Rated}} * \text{Cosine (Alignment Error)}$$

Inaccuracy of commutation alignment can occur from multiple sources when using encoders. The accuracy of the hall channel devices, if they are provided from an encoder using an optical disc, are typically accurate to 5° or better electrically. When they are integral to the motor, they may have an error of up to 15°. Using the above equation, a 15° error would still provide more than 96% of the motor's torque.

The accuracy of the 'wake and shake' algorithms used in MENCTYPE 1, MENCTYPE 2, MENCTYPE 3, and MENCTYPE 4 are subject to many outside influences, such as friction and inertia. These algorithms are not robust and are subject to varying amounts of error.

Incorrect commutation alignment also causes differences in efficiency according to direction. In an exaggerated example, a misaligned commutation angle may allow a 1500 RPM motor to go 2000 RPM in one direction and only 1000 RPM in the other.

## ***Physical Encoder Alignment***

The SERVOSTAR provides a number of features (variables) to allow adjustment of the encoder signal alignment through the software. These features can be very useful, but you must be careful when using them. If the alignment of the encoder to the motor is left to chance, swapping out the motor or encoder requires that these variables be recalibrated for the new alignment. Is this acceptable in the given application? You may not be certain that the knowledge to do so will remain in the future. A better method is to align the encoder on the motor. This makes swap-out a simpler process.

MENCTYPE 0 (A/B/I and Halls) has hall channels aligned to the motors back EMF. This is accomplished by rotating the motor via an external source, monitoring the signals from the hall effect channels while monitoring the voltage generated by the motor and rotating the encoder housing until the waveforms overlap. The encoder mounting screws are then secured. This aligns the hall channels and the marker channel must then be aligned using the MECNOFF variable. Caution must be exercised as motors may generate lethal voltages when rotating.

MENCTYPE 1 and MENCTYPE 2 (A/B/I without Halls) require the marker to be aligned to the motor's BEMF waveform. Danaher Motion Kollmorgen has not defined any particular alignment standard. Defining your own alignment standard could be beneficial. MENCTYPE 3 and MENCTYPE 4 (A/B only) require no alignment or adjustments. MENCTYPE 6 (A/B/I with Halls) requires the same alignment as MENCTYPE 0 but does not require that MENCOFF be set.

When it is not practical to perform mechanical alignments, the software adjustment method can be used. The MPHASE variable holds an offset for the Hall channels and can be used to effectively 'shift' the Hall channel position. It is possible to invert the effective direction as established by the A and B channels using the MFBDR variable. It is also possible to invert any one or all of the hall channels. The MHINVA, MHINVB, MHINVC variables allow the drive to receive the hall channels and act upon them from an inverted nature.

## ***MENCNOFF***

The MENCNOFF variable holds a marker offset and is used to align the commutation in MENCTYPE 0, MENCTYPE 1, and MENCTYPE 2. To determine the setting for MENCNOFF perform the following steps using the **MOTIONLINK**<sup>®</sup> terminal mode with power on the drive and C3 unplugged (disabled):

1. Enter 'ENCINIT'.
2. Rotate the motor shaft two turns clockwise by hand.
3. Verify that the process is complete by entering 'ENCINITST'. The **SERVOSTAR** should return '2' if the process has been successfully completed.
4. If not, repeat steps 2 and 3.
5. Enter 'SAVE'.
6. Use caution to continue testing the system.
7. The MENCNOFF variable may be manually trimmed for best performance.

When using MENCNOFF with MENCTYPEs 1 and 2, the correct value must be determined through trial and error. Pick a setting and trim it, watching for the speed (V) to be equal in both directions when applying torque in OPMODE 2. It is common for repeated tries of this procedure to return values that are significantly different due to the software's reference point being different from try-to-try. This is normal.



***The motor shaft must be free to rotate uncontrolled without damage to equipment or personnel.***

# System Phasing

With so many signals coming from the encoder back to the drive and then the signals going to the motor, it can become quite frustrating to make sure that each signal is of the appropriate phase.



*This diagram shows the commutation phasing (PFB counts down) for:*

*Motors with shafts, counter-clockwise rotation viewing shaft end.*

*Motors without shafts, clockwise rotation viewing lead exit end.  
Linear motors, with armature moving away from leads.*

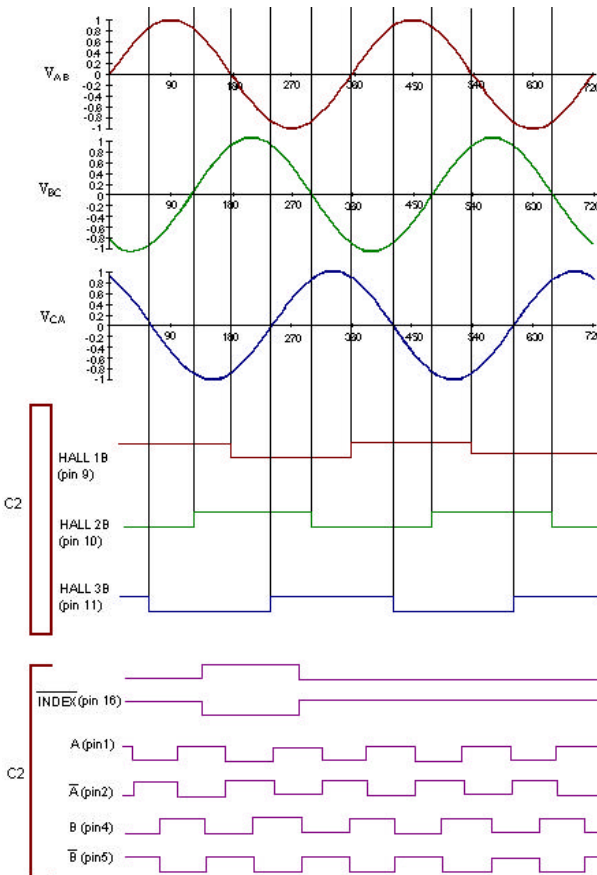



## *Troubleshooting*

Several problems can occur with encoder-based systems. The most common problem is miswiring. The section on system phasing (above), provides the necessary troubleshooting information.

Miswired Hall channels can cause intermittent problems. With miswired Hall channels, the motor operates correctly sometimes, but will occasionally not operate correctly after cycling power. It is very important to physically verify the Hall effect channels. There is a command in the **SERVOSTAR** manual called, "HALLS." It returns the hall code as "read." It is important that the installation and startup procedures for the machine sequence the motors through all the appropriate hall codes to make sure they are present and in the right sequence.

An 'illegal hall code' error occurs if the Hall channels go to all low or all high conditions. A broken wire or misphased channel can cause this problem.

It is important that the A and the B channels be wired appropriately to the **SERVOSTAR** drive to ascertain the correct directional drive information. This can be verified by displaying the PFB variable while rotating the motor shaft clockwise. The PFB variable should be counting in a more positive direction. If it counts in a negative direction, the A and B channels are inverted. This can be fixed by swapping the A and /A wires from the encoder or by using the MFDIR command.

A/B Line Break errors may occur and can be misleading. The **SERVOSTAR** receives the A/B/I channels in a differential format. Each channel is fed into a bridge rectifier to create a DC voltage that is monitored for presence. Absence of any one of these three voltages (except the I channel in MENCYTYPE 3, MENCYTYPE 4, and MENCYTYPE 6) cause an A/B line break fault.

## LINE DRIVERS, RECEIVERS, AND TERMINATIONS

Counting pulses sent over cables going through an industrial environment requires that care be taken to prevent noise induction on the cable that looks like an encoder pulse. Running wires in a "clean" raceway is one requirement.

Another common sense approach is to use differential transmission for the signals to provide the highest degree of noise immunity. Differential line drivers are required by the **SERVOSTAR**. The differential line signals follow the RS-485 format where pulses are sent up and down a 120 $\Omega$  cable. Termination is expected at both ends and the **SERVOSTAR** provides the required termination. Deviations from a 120 $\Omega$  characteristic impedance cable when using long cables can result in poor performance.

## ***Design Considerations***

The SERVOSTAR has a maximum frequency input for incremental encoders of 2.5 MHz. This cannot be exceeded under any circumstance.

Encoders consume 5 V. The 5 V is typically regulated inside the drive through a cable to the encoder. Tolerances on the 5 V must be considered for IR loss within the cable. An 18 AWG conductor pair providing the 5 V at a 250 mA drive result in approximately ¼V drop and become the limits from the encoder's 5 V rating perspective. Consideration of cable length 5 V current draw is extremely important for good system design. The SERVOSTAR's encoder supply is 5 V ± 2% with 250 mA maximum draw.

When using incremental encoders, the SERVOSTAR receives the encoder pulses, buffers them electrically and then outputs them to the encoder equivalent output port. The phase delay in the transport of these signals is extremely small. Be sure to run all encoder cables in conduit or wire tray that is free from wires carrying or emitting electrical noises such as solenoid wires and armature cables.

## ***Reference Variables***

For additional information on any of these commands, refer to the *SERVOSTAR® S and SERVOSTAR® CD VarCom Manual*.

**ENCINIT** - This command triggers the encoder initialization process.

**ENCINITST** - This variable may be queried and returns status of the initialization process. This variable assumes one of three values:

**0** = The initialization process has not started.

**1** = The initialization process is in progress.

**2** = The index position has been determined and the initialization process is complete. The flag is reset to zero when you manually set the index position.

**ENCSTART** – Selects automatic or manual "wake and shake" initialization.

**HALLS** - Read the states on the Hall channels.

**IENCSTART** - Set the "wake and shake" initialize current level.

**MENCOFF** - Tell the SERVOSTAR where the marker is relative to commutation angle 0.

**MENCRES** - Tell the SERVOSTAR how many lines there are on the encoder.

**MENCTYPE** - Tell the SERVOSTAR what encoder signals are present.

**MHINVA** - Invert the active level of Hall channel A.

**MHINVB** - Invert the active level of Hall channel B.

**MHINVC** - Invert the active level of Hall channel C.

**MPHASE** – Allows commutation offset.

## *Example*

This procedure is for commutation only and assumes analog (OPMODE 3)operation.

- 1) **Define a Positive Motor Direction**  
This is somewhat arbitrary, but must be consistent. To keep confusion to a minimum, try to match the motor's definition of A+/A- and B+/B- to the CD definitions for purposes of hardware connections. With these encoder connections made, push the motor by hand and read the PFB variable. The motor direction which causes PFB to become more positive is the positive motor direction. When testing motor phase voltages and Hall phases in subsequent steps, always push the motor in this positive motor direction.
- 2) **Determine the Desired Commutation Method**  
For this example, an encoder is used with A/B signals and Hall sensors for commutation, but without encoder index pulse. This allows reasonably accurate commutation without "wake and shake" motion and without a specific index-based commutation offset. This is equivalent to MENCTYPE=6.
- 3) **Determine the Relationship Between Halls and Motor Phases**  
Measure the motor phase voltages versus the Hall states on an oscilloscope to determine which motor phase matches which Hall sensor. If the zero crossings of the sine wave match the edges of the Hall sensor, this is a match. If the the Hall sensor is low during the positive peak of the sign wave, this follows the default polarity definition of the CD amp and you should set MHINV<sub>x</sub>=0. If the Hall sensor is high during the positive peak of the sine wave, set MHINV<sub>x</sub>=1.



*If desired, record the difference between the sine zero crossings and the Hall edges as an estimate of the MPHASE value to use in step 8.*

- 4) **Determine the Correct Hall Phase Sequence**  
Connect the Halls to the CD, leaving other inputs/outputs disconnected or disabled. Push the motor by hand in the positive motor direction. Use the HALLS command to verify that the sequence is 001, 011, 010, 110, 100, 101. Re-arrange the Hall sensor leads until you find the combination that yields the proper binary counting sequence while moving the motor in the positive motor direction.
- 5) **Determine the Proper Motor Phase Sequence**  
Connect motor phases to the CD. Send ZERO 1 to force the motor to move to a known "zero" state. Enable the drive. This causes motion to the zero position. Read the HALL state, it should be 001. If this is not the Hall state, re-arrange the motor leads and repeat until ZERO yields the proper HALL state.
- 6) **Save Settings**  
At this point, everything should be working properly. Save the settings to the CD's EERAM and to disk.
- 7) **Confirm Proper Commutation at All Initialization Conditions**  
Disable the drive. Push the drive by hand until the HALL state is 001. Turn off power to the drive and wait for the LED display to go blank, then wait 5 seconds more. Turn on power to the drive. Slowly increase positive DAC input to the drive until motion just begins in the positive direction. Slowly decrease negative DAC input to the drive until motion just begins in the negative direction. The positive and negative DAC values should be approximately the same (assuming the linear motor is level). Repeat this process by starting from each of the six Hall states.
- 8) **Confirm Proper Operation in the Application Conditions**  
Tune the servo loop. Command aggressive moves and the highest acceleration used by the application. Observe the peak value of DAC input required for forward and reverse motion. These values should be approximately the same (within about 10%). If desired/required, adjust MPHASE up or down to give equal peak DAC output in both directions.

# APPENDIX D

## Resistive Regeneration Sizing

Shunt regeneration is required to dissipate energy that is pumped back into the DC bus during load deceleration. The loads need to be defined in terms of system inertia, maximum speed, and deceleration time. In addition, the duty cycle must be known.

Regen Resistor  
 Example is  
 Kollmorgen's ERH-26

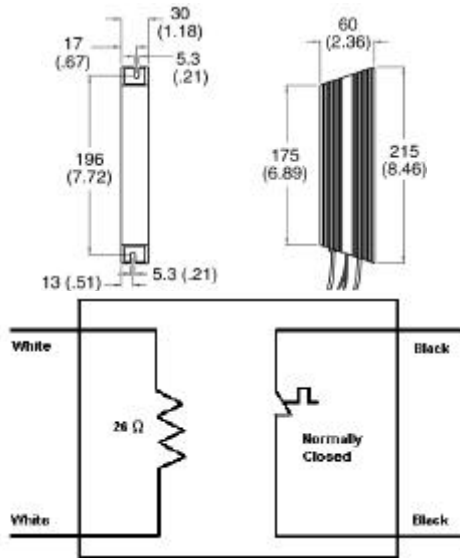

The black wires are for the thermostat and the white wires are for the regen resistor on the external regen resistor (pictured above).

## Energy Calculations

To determine if a system needs a regeneration resistor, use the following procedure:

### EQUATION 1

Define the term  $E_M$  which is the kinetic energy of the motor/load minus the system losses.

$$E_M = (1.356/2)(J_M + J_L) \omega_M^2 - 3I^2M (R_M/2)t_d - (1.356/2)T_F \omega_M t_d \text{ Joules}$$

Where:  $J_M$  = rotor inertia (lb - ft - sec<sup>2</sup>)

$J_L$  = load inertia (lb - ft - sec<sup>2</sup>)

$\omega_M$  = motor speed before decel (rad/sec) =  $\frac{\text{RPM}}{9.55}$

$I_M$  = motor current during deceleration

$R_M$  = motor resistance (Ω L - L)

$t_d$  = time to decel (sec)

$T_F$  = friction torque (lb-ft)

If this energy is less than that which the BUS Module can store, then no regen resistor is needed. Thus, the condition for which no regen resistor is required is:

### EQUATION 2

$$E_M < (1/2) C (V_M^2 - V_{NOM}^2)$$

Where:  $C$  = BUS Module capacitance (Farads)

$V_M$  = max BUS voltage (V)

$V_{NOM}$  = nominal BUS voltage (V) =  $V (L-L) \sqrt{2}$

Where: all negative  $E_M$  are set equal to zero before summation (sum all non-negative  $E_M$ ). This represents a worst case in which only the motors that are regenerating ( $E_{MJ} > 0$ ) decelerate while those whose system losses exceed their regenerative energy ( $E_{MJ} \leq 0$ ) remain idle. If Equation 2 is not satisfied, then a regeneration resistor is required.

## Regeneration Calculations

The procedure for calculating regeneration requirements is twofold. Both the regen resistance value and the resistor wattage rating must be determined.

## DETERMINING RESISTANCE VALUE

The maximum allowable resistance of the regen resistor is that value which will hold the BUS under its maximum value when the regen circuit is initially switched on. For an AC servo system, the maximum allowable regen resistance is given by:

### EQUATION 3

$$R_{MAX} = \frac{V_M^2}{V_B I_M \sqrt{3}}$$

Where:  $V_M$  = maximum BUS voltage  
 $V_B$  = motor back EMF less motor losses

### EQUATION 4

$$V_B = K_B N - \sqrt{3} I_M (R_M / 2)$$

Where:  $K_B$  = back EMF constant (V (L-L) /KRPM)  
 $N$  = motor speed prior to decel (KRPM)  
 $I_M$  = deceleration current in motor ( $A_{RMS}$  / phase)  
 $R_M$  = motor resistance (Ω-L)  
 $I_M$  = deceleration current in motor ( $A_{RMS}$  / phase)

## DETERMINING DISSIPATED POWER

The average wattage rating of the regen resistor is a function of energy to be dissipated and the time between decelerations. This average wattage rating for a single axis system is given by:

### EQUATION 5

$$P_{AV} = \frac{E_M - (1/2)C(V_M^2 - V_{HYS}^2)}{t_{cycle}}$$

Where:  $t_{cycle}$  = time between decels + time to decel (sec)  
 $V_{HYS}$  = hysteresis point of regen circuit

When the time between decelerations becomes very large, Equation 5 become very small. In cases such as these, the average wattage is not a meaningful number. Peak wattage and the time which the resistor will see peak wattage become the main concerns. The peak wattage of the regen resistor is:

$$P_{PK} = \frac{V_M^2}{R_{REGEN}}$$

Where:  $R_{REGEN}$  = REGEN Resistance



## APPENDIX E

### Series 5 UCB2 Digital Control Board

The SERVOSTAR<sup>®</sup> servo amplifiers incorporate a number of additional features in the Series 5 model. The addition of these features is possible due to an upgrade to the UCB2 digital control board.

### Part Number

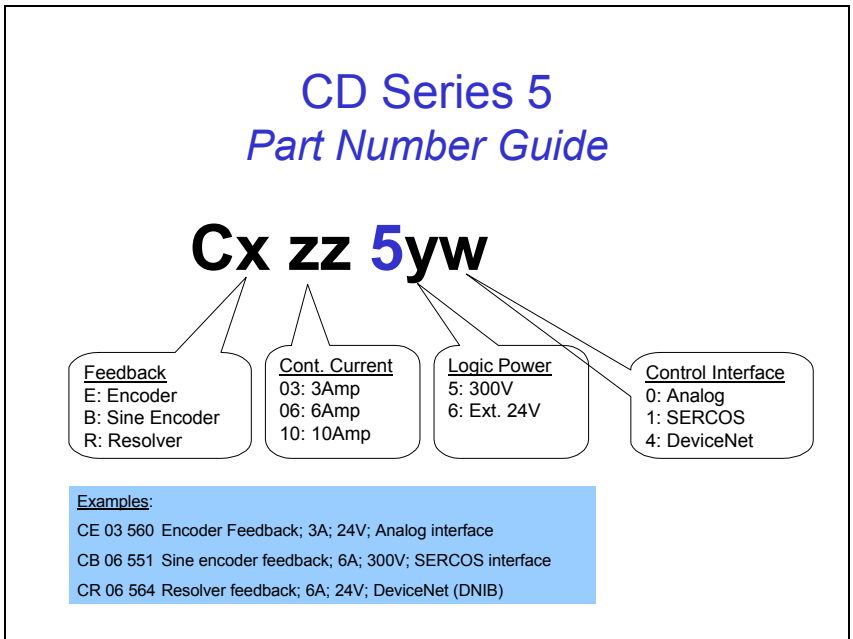

## Summary of New Features

Feature	Description
Sine encoder	Sine encoder feedback is supported on the main control board. Interpolation level is set up to 4096 (MSININT).
Sine encoder calibration	Sine encoder signals are calibrated in order to increase the accuracy of the interpolation (SININIT).
Stegmann Hiperface	Support Hiperface (Stegmann) interface. MENCTYPE=10.
SERCOS	SERCOS interface level-A compliance is implemented. All serial commands are supported by SERCOS IDNs.
Support for CD600	Added support for SERVOSTAR CD600 (Two power IDs were added, 6/12 and 10/18). "SERVOSTAR CD600" appears as the drive model in the response to VER command.
Encoder simulation	Pulse up/pulse down mode for encoder simulation added with ENCOUTMOD command.
Encoder initialization	For feedback devices without an absolute position indication, a zero motion encoder initialization process is supported (Wake-no-Shake encoder initialization process).
Software Resolver	The resolver-to-digital (RDC) conversion is accomplished in the Series 5 products using software techniques.
Extended I/O	Additional I/O.

## Differences from Previous Models

- TRUN, the drive run time counter is NOT reset by CLREEPROM. Use TRUN 0 to reset this counter.

## Encoder Simulation

The encoder simulation signal is generally generated in the A-quad-B format. The addition of ENCOUTMOD enables you to change this format to a pulse up/down signal.

## Encoder Initialization

In brushless 3-phase motors, the torque generated by the motor depends on the three-phase currents and motor position. In order to properly control the motor and extract maximum torque out of the available motor and power stage, the controller must be provided with the current motor position. In encoder-based systems, the initial position for commutation initialization is found using hall sensors switching, index finding, or an appropriate commutation-lock algorithm (or a combination of the three methods). Encoder initialization without motion uses a commutation-lock algorithm.

On power up, since the absolute motor position is unknown, two methods may be implemented:

- Applying a forced commutation to move the motor to a predetermined position where the torque generated is zero and updating controller variables accordingly.
- Using a motion control algorithm that brings the commutation angle of the motor from the initial, unknown position to the current motor position (instead of moving the motor).

The first method is currently implemented on the SERVOSTAR CD. The disadvantage of this method is that it requires the motor to be moved. This produces a jumpy motion that may not be tolerable in some cases (for example - linear motors applications).

The second method is designed to solve this problem by implementing a closed loop commutation-lock algorithm that adjusts the commutation angle to the motor position rather than moving the motor to a predetermined place. The motor moves very slightly. Motion of at least  $\pm 4$  electrical degrees is expected.

## ***The Process***

1. Disable the drive.
2. Select the encoder initialization process by entering the instruction, *INITMODE 2*.
3. Set the encoder initialization current using *IENCSTART*. Set this to the maximum allowed application current.
4. Set the gain for the process using *INITGAIN* (typically 1000).
5. Initialize the process by using *ENCSTART*.
6. Enable the drive.
7. Monitor the process by reading the status word, *STATUS2*, and the status of *ACTIVE*.

If the process completes successfully, the drive is enabled, and *ACTIVE* = 1. If the process is not successful, bit 2 in the first word of *STATUS2* is set.

## Sine/Cosine Calibration

---

The software Sine Encoder and software resolver algorithms are based on sampling the incoming sine and cosine signals. The accuracy of the process depends on the sampling accuracy of the sine and cosine values. In order to prevent accuracy degradation due to electronic component tolerances, the sine and cosine values must be gain- and offset-compensated.

The process of finding the gain and offset compensation parameters is called “Sine Zero”. The process matches an amplifier to an encoder or resolver after replacing a motor or an amplifier. After the process terminates the gain and offset values are stored in the non-volatile memory, they are loaded each time the amplifier is powered on.

The process includes finding 128 maximum and minimum, Sine and Cosine peaks and calculating the average gain and offset values. Due to accuracy restrictions, the motor must be rotated at a slow speed so the Sine/Cosine waves generated are at a frequency low enough for a valid result. The speed must be such that the frequency of the Sine/Cosine signals does not exceed 250Hz. For a rotary motor, the maximum motor speed in rpm is calculated as:

$$60 \times 250 / (\text{MENCRES} \times \text{MSININT})$$

For a linear motor, the maximum motor speed in mm/sec is calculated as:

$$250 \times \text{MPITCH} / (\text{MSININT} \times \text{MENCRES})$$

### *The Process*

During calibration, the motor is either moved manually or under servo control (preferably under velocity control). Take the following steps:

1. Initialize the process by entering the instruction, *SININIT* (without parameters)
2. Move the motor in either direction. While moving the motor, query the status using *SININIST*.
3. The process is complete when *SININIST* returns a value of 3 (done) or 5 (fault).

# Wiring Diagram

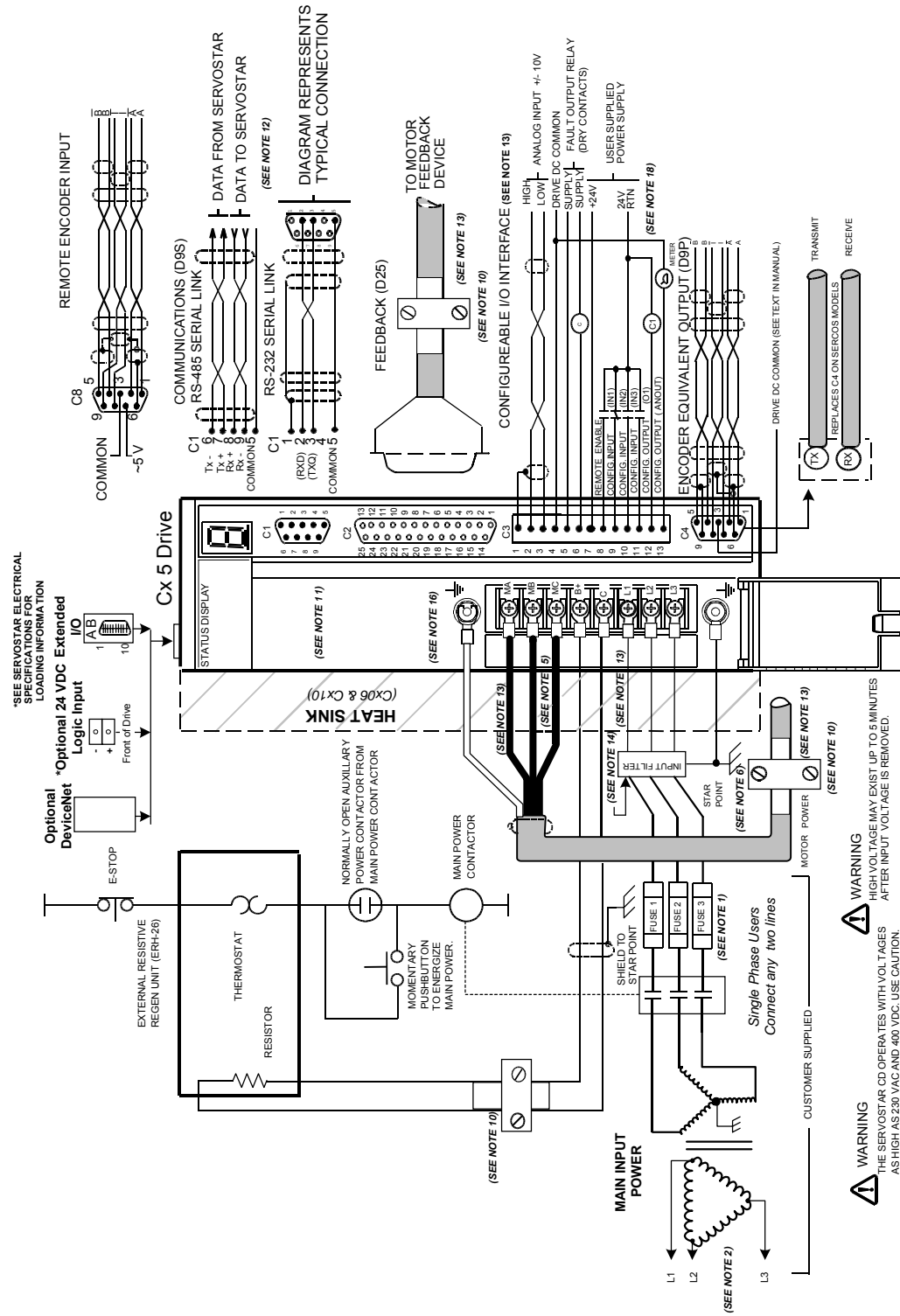

\*SEE SERVOSTAR ELECTRICAL SPECIFICATIONS FOR LOADING INFORMATION

Optional DeviceNet Logic Input Front of Drive

E-STOP

EXTERNAL RESISTIVE REGEN UNIT (ERH-26)

THERMOSTAT RESISTOR

NORMALLY OPEN AUXILIARY POWER CONTACTOR FROM MAIN POWER CONTACTOR

MOMENTARY PUSHBUTTON TO ENERGIZE MAIN POWER.

MAIN POWER CONTACTOR

HEAT SINK (Cx06 & Cx10)

STATUS DISPLAY

Cx5 Drive

C1

C2

C3

C4

C8

COMMON

-5V

REMOTE ENCODER INPUT

COMMUNICATIONS (D9S)

RS-485 SERIAL LINK

DATA FROM SERVOSTAR

DATA TO SERVOSTAR

RS-232 SERIAL LINK

DIAGRAM REPRESENTS TYPICAL CONNECTION

TO MOTOR FEEDBACK DEVICE

FEEDBACK (D25)

CONFIGURABLE I/O INTERFACE

HIGH ANALOG INPUT +V, 10V

LOW ANALOG INPUT -V, 10V

DRIVE DC COMMON SUPPLY

RELAY OUTPUT CONTACTS (DRY CONTACTS)

USER SUPPLIED POWER SUPPLY

24V RTN

ENCODER EQUIVALENT OUTPUT (D9P)

TRANSMIT

RECEIVE

DRIVE DC COMMON (SEE TEXT IN MANUAL)

REPLACES Cx ON SERVOSTAR MODELS

**WARNING**  
HIGH VOLTAGE MAY EXIST UP TO 5 MINUTES AFTER INPUT VOLTAGE IS REMOVED.

**WARNING**  
THE SERVOSTAR CD OPERATES WITH VOLTAGES AS HIGH AS 230 VAC AND 400 VDC. USE CAUTION REFER INSTALLATION AND TROUBLESHOOTING TO QUALIFIED PERSONNEL ONLY.

Single Phase Users  
Connect any two lines

CUSTOMER SUPPLIED

# Top View

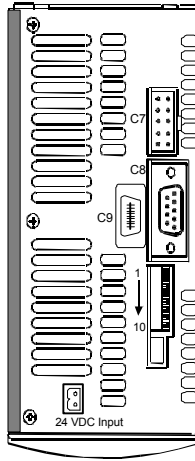

## Connector Pin-Out

Pin No.	Function	Description	Comments
A1			
B1			
A2			
B2			
A3	IN5		Bi-directional
B3	IN4		Bi-directional
A4			
B4	IN6		Bi-directional
A5			
B5	Common For IN4 to IN6	Common For IN4 to IN7	
A6			
B6			
A7			
B7			
A8			
B8			
A9			
B9			
A10			
B10			

# Sine Encoder Feedback

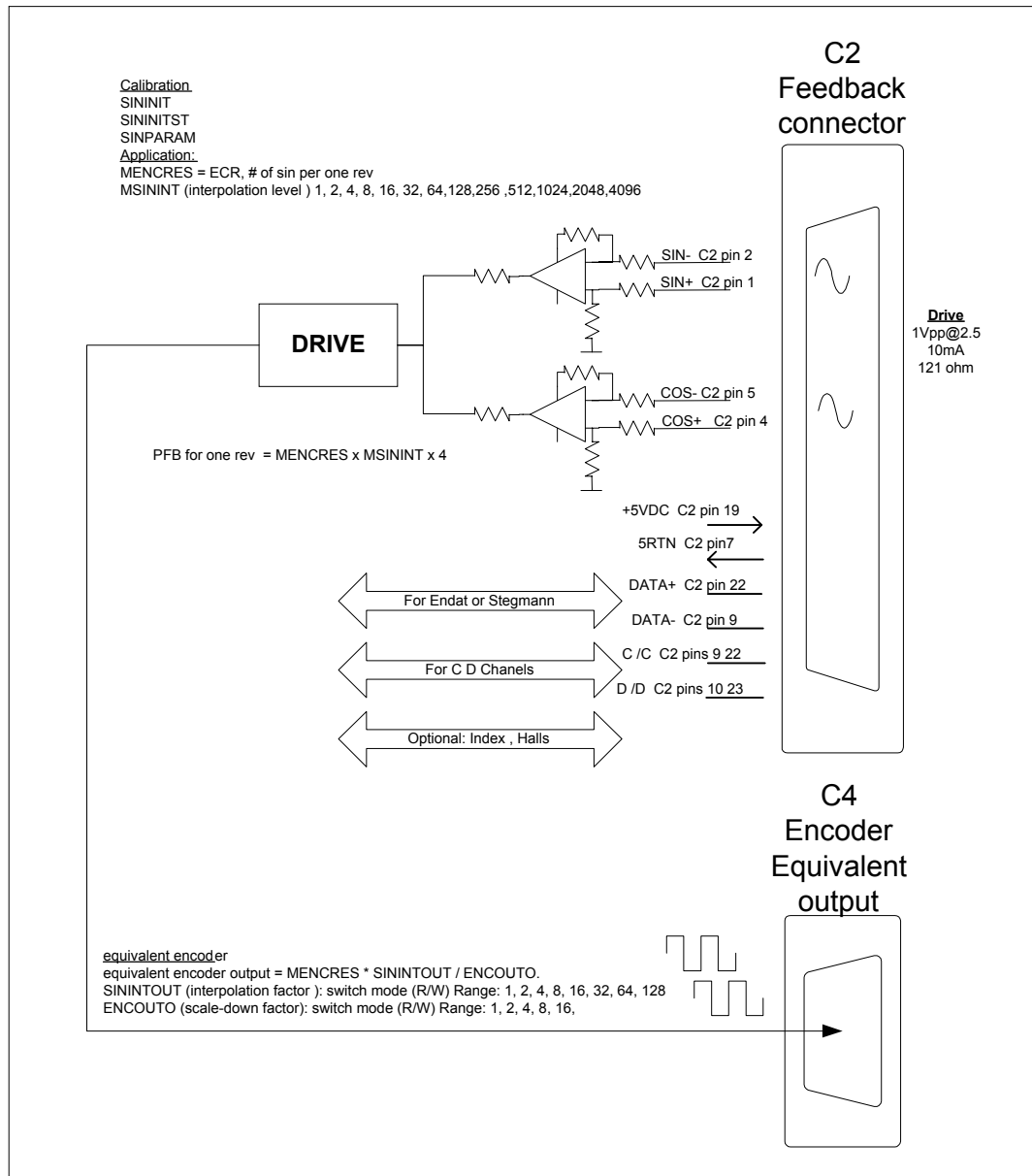

# Resolver Feedback

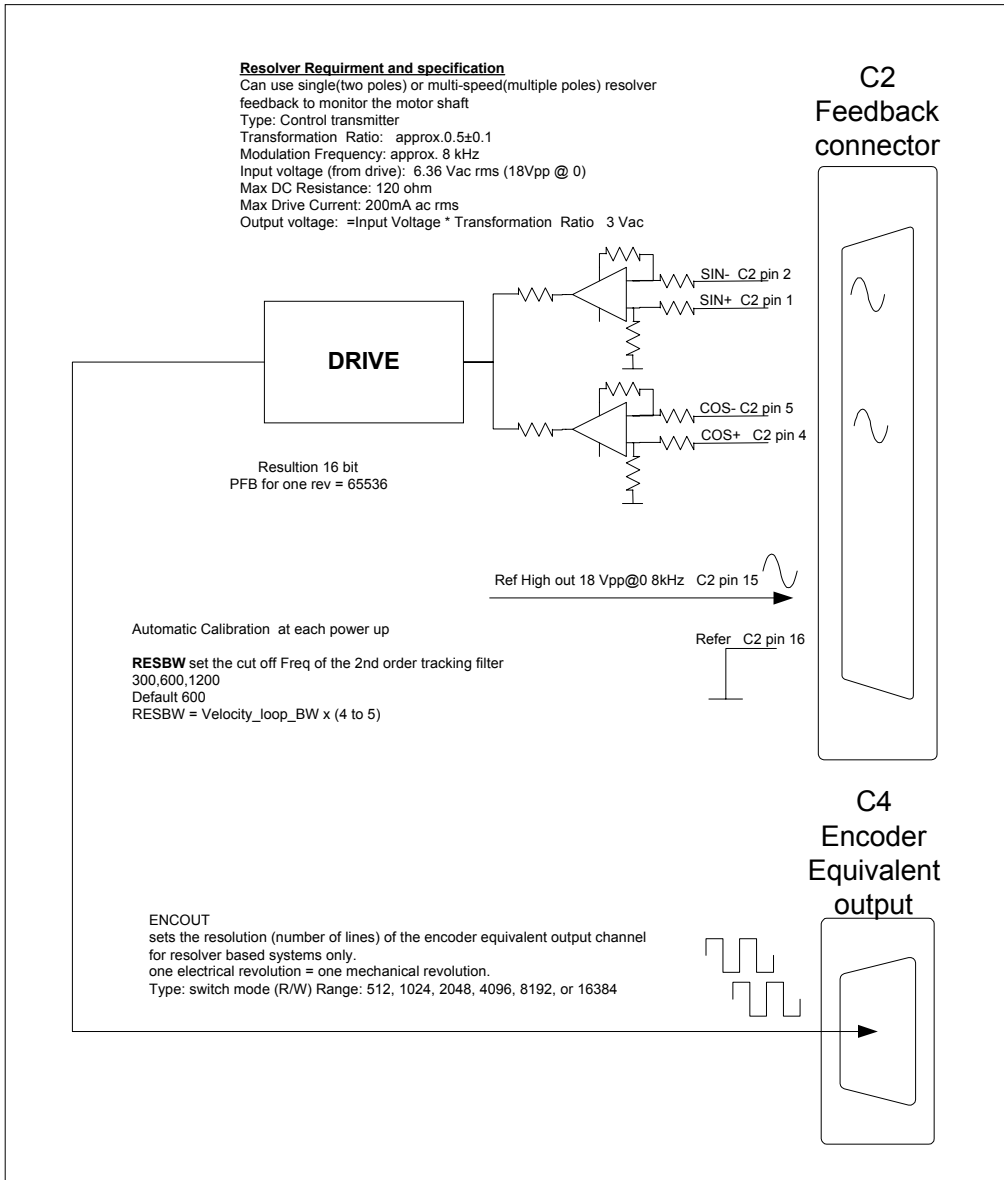



---

## Software Resolver Interface

---

The resolver-to-digital (RDC) conversion is accomplished in the Series 5 products using software techniques, as opposed to using a dedicated integrated circuit. The benefits of this mechanism include:

- Enhanced system performance because the resolution is not a function of the velocity.
- Increased accuracy due to the ability to calibrate and match the Sine and Cosine signals.
- Increased reliability due to the use of fewer components.

### *The Process*

The software resolver implements a second-order tracking filter that uses feed-forward to zero (ideally) the tracking error for constant speed. RESBW is the filter bandwidth and the tradeoff is: the higher the bandwidth, the faster the response and the more the system is prone to noise.

The Sine and Cosine signals of the resolver are calibrated to increase the accuracy of the measurement. The calibration process is described above in the section *Sine/Cosine Calibration*. This process is initialized automatically at each power up. Old parameters are used until the calibration process generates new parameters so there is no need to explicitly enter SININIT.

---

## Extended I/O

---

The SERVOSTAR CD Series 5 hardware has 3 additional digital inputs in addition to the standard I/O. These inputs are accessible through the 20-pin connector located on the top of the drive. The pins on this connector are arranged in two rows (A & B) of 10.

For information on the new commands, refer to the *SERVOSTAR<sup>®</sup> S and SERVOSTAR<sup>®</sup> CD VarCom Reference Manual*.