

file: 430txman 12-98 draft Aug. 31, 2005

# Arecibo 430 MHz Radar System

## Operation and Maintenance Manual



Written by Jon Hagen  
April 2001, 2nd ed. May 2005

## NOTE

**With its high-voltage and high-power, and high places, this transmitter is potentially lethal. Proper precautions must be taken to avoid electrical shock, RF exposure, and X-ray exposure. (See Section 22).**

### Emergency Procedure: ELECTRIC SHOCK

#### Neutralize power

1. De-energize the circuit by means of switch or circuit breaker or cut the line by an insulated cutter.
2. Safely remove the victim from contact with the energy source by using dry wood stick, plastic rope, leather belt, blanket or any other non-conductive materials.

#### Call for help

1. Others can help you administer first aid
2. Others can call professional medical help and/or arrange transfer facilities

### Cardio Pulmonary Resuscitation (CPR)

1. Check victim's ABC

A - airway: Clear and open airway by head tilt - chin lift maneuver

B - breathing: Check and restore breathing by rescue breathing

C- circulation: Check and restore circulation by external chest compression

2. If pulse is present, but not breathing, maintain one rescue breathing (mouth to mouth resuscitation) as long as necessary.
3. If pulse and breathing are absent, give external chest compressions (CPR).
4. If pulse and breathing are present, stop CPR, stabilize the victim.
5. Caution: Only properly trained personnel should administer CPR to avoid further harm to

the victim.

Administer first aid for shock

1. Keep the victim lying down, warm and comfortable to maintain body heat until medical assistance arrive. Don't move the victim unless absolutely necessary. Do not be in a hurry to transport the victim, more harm may be done by mishandling, jarring and shaking the victim.
2. Don't give fluid (drinks) to the victim unless necessary.
3. Keep checking the victim until medical help is obtained.

## **Table of Contents**

- Section 1: Introduction
  - 1.1 Purpose and scope of this manual
- Section 2: Specifications.
  - 2.1: Loss in the waveguide transmission system
  - 2.2 Increasing the bandwidth
- Section 3: Brief description w/ block diagrams & pictures
- Section 4: Operating instructions
- Section 5: Litton L-3403 Klystrons
  - 5.1 Klystron frequency shift
- Section 6: Final amplifier RF circuitry
- Section 7: Harmonic filter and EH tuner
- Section 8: Dummy load
- Section 9: Intermediate power amplifier (IPA)
- Section 10: Low-power RF and pulse circuitry
- Section 11: High voltage power supply
- Section 12: Crowbar, Reflected Power Detectors, and Arc Detectors
- Section 13: Modulator
- Section 14: Cooling system
- Section 15: Monitoring system, including waveguide receiver sample port
- Section 16: AC power control circuitry
- Section 17: Timing system (timing generator)
- Section 18: Receiver protection (monoplexers & drivers)
- Section 19: Waveguide run to platform and rotary joint.
- Section 20: Platform power divider and linear joints
- Section 21: Turnstile junctions
- Section 22: Safety systems & hazards: radiation, high-voltage, X-ray, Chemical
- Section 23: Maintenance
- Section 24: Trouble-shooting/spare parts inventory
- Section 25: Glossary, acronyms and abbreviations
- Section 26: Overall list of schematic diagrams and other associated documentation
  - Section 26.2: List of schematic diagrams appended to this manual
- Section 27: Pending Modifications
- Section 28: Index

## **1. Introduction**

The 430 MHz radar transmitter at Arecibo Observatory was built in 1962 by Levinthal Electronic Products, which became Radiation at Stanford, as original equipment for the observatory. The project engineer was Gene E. Talmadge. The transmitter operates at a fixed center frequency of 430 MHz with a maximum transmitted bandwidth of 1 MHz (see Section 2.1) Two Litton L-3403 or L-5773 klystrons operate in parallel as a balanced amplifier, with a 90-degree power splitter at the input and a high-power 90-degree combiner at the output, to provide a maximum total peak pulse output power of 2.5 MW. Power is delivered to the antenna platform via 1500 feet of WR2100 waveguide. An infinitely variable power splitter on the platform provides transmitter power to feed antennas in both the Gregorian dome (a feed horn) and the carriage house (the line feed). This allows *dual beam* operation, which could have been called “dual radar” operation, as it is equivalent to two radars pointing in different directions. The maximum beam duty factor is 6% so the maximum average output power is 150 kW.

The limited bandwidth of the klystrons forces pulse rise and fall times to be no less than about 0.5 microsecond. Beam pulse lengths can be varied from 2 to 2,000 microseconds. Within the pulse, amplitude and/or phase modulated can be applied to the RF drive. The high power modulating (turn on/turn off) circuitry for the klystron beam constrains the pulse repetition frequency (PRF) to a maximum of 1 kHz. For more closely spaced pulses, one may modulate the low-level RF drive at frequencies up to 1 Mhz while keeping the beam current on. Note: In this mode it is still necessary to limit the beam duty factor to 6%. Moreover, the beam must always be off while receiving because klystron-produced noise leaks across the turnstile junction (T/R diplexer) and into the receiver.

### **1.1 Purpose and scope of this manual**

Sections 2 through 5 of this manual serve as a users' manual, updating the original manuals and drawings and adding sections to cover the ancillary equipment: receiver protection, and related interlocks, feed line, and other platform mounted waveguide components. The equipment and the control console are described in sufficient detail for a scientist to gain confidence in operation of the transmitter. Sections 6 through 12 are intended for maintenance engineers and technicians. This manual, together with a subset of the original documentation, listed in Section 25, comprise the available documentation for the 430 MHz transmitter.

## **2. Transmitter Specifications**

Transmitter designation: Radiation at Stanford Model PC-349

Klystron type: Litton L-3403 or L-5773 (two); 10ft tall, 840 lbs, surrounded by a 2900 lb

solenoid magnet.

Center Frequency: 430 MHz ,adjustable from 400 to 450 MHz, except for linear joint (see sec. 20)

Frequency stability: better than 2 parts in  $10^{11}$  over periods of 1 sec to 1 hr. (determined by station frequency standard)

Phase Stability: see Section 5.1

Maximum instantaneous bandwidth: 2 MHz (see next section)

Maximum Peak Power at transmitter output: 2.5 kW

Maximum Avg. Power at transmitter output: 150 kW

Maximum beam duty factor: 6% (Originally an optional *cw mode* was provided, presumably based on a cw specification for the original pair of Varian klystrons. The current Litton klystrons are specified only for pulsed operation.

Efficiency: 44% to 48%

Power supply max. rating: 120,000 V @ 4.4 A (run at 90kV to 95kV for Litton L-5773 klystrons).

Power supply regulation: 12% no load to full load

Waveguide system attenuation: 1dB

Maximum PRF: 1kHz

Minimum PRF: none

Maximum pulse length:  $\pm$  2.1 ms

Minimum pulse length: 20 usec.

Beam Current Rise and Fall time: 5 usec minimum

Power output variation: less than 0.2 dB pulse-to-pulse after 15 minutes warmup

Output pulse shape: rectangular (shaped pulses can be obtained by modulating the RF drive.

Output power adjustability: continuously adjustable to -20 dB

Interpulse noise: The noise contributed by the klystron beam is less than 750 Kelvins.

(This is reduced approx. 30 dB to 0.75 Kelvins by the isolation in the TR turnstile junction).

EIRP: the 430 transmitter supplies about 2MW peak power up to the antenna. The antenna has a 62dB gain, so the EIRP is  $2 \times 10^{6.2}$  MW = 3.2 million Megawatts peak. The average 430 MHz EIRP is 6% of the peak or 224,000 Megawatts.

Beamwidth: is given by  $\lambda/\text{dish diameter} = .7\text{m}/300\text{m} = .0023$  radians = 0.13 degrees.

Other Arecibo transmitting systems, for comparison:

The S-band transmitter supplies 1MW (peak and average) to the antenna. The gain is 74dB

so the EIRP is  $1 \times 107.4 \text{ MW} = 25 \text{ million Megawatts}$ .

The beamwidth of the 2380 radar system is 1.9 arc minutes or 0.032 degrees.

The 46.8 MHz transmitter supplies the antenna with 40kW peak and 2 kW average. The gain is around 37dB (assuming the yagi feed produces an aperture efficiency of 25%), so the EIRP is  $40\text{kW} \times 103.7 = 200,000 \text{ kW}$  peak and 10,000 kW average.

The beamwidth at 46.8 MHz is  $6.4/300 = .02$  radians or 1.2 degrees.

## 2.1 Loss in the waveguide transmission system

The overall loss in the transmission system was measured directly with a signal generator and power meter and found to be about 1 dB. This is due to the sum of the ohmic losses in the E-H tuner, waveguide run, rotary joint, linear joint, and waveguide tuner, which seem to total about 0.9dB, increased to 1 dB by the presence of standing wave ratio in the line of about 1.9:1. Thus, when the klystrons are putting out a total of 2.5MW, the power exiting the antenna is only about 1.96 MW.

Note: the power dissipated by losses in a transmission line are the sum of the dissipations caused by the the forward wave and the reverse wave, as if they existed independently. Therefore, if a forward wave of unit power is sent into the downstairs end of the waveguide, the forward power arriving at the top will be  $G$  where the 'gain',  $G$ , would be, for example, 0.75 if 25 percent of the forward power is lost to dissipation. If the voltage reflection coefficient at the platform end is  $\rho$ , then the power transmitted by the feed will be  $G(1-\rho^2)$ . The reflected power, arriving back at the downstairs end will be  $G^2 \rho^2$ . Therefore, the overall gain, i.e., power transmitted / net power into the line is given by  $G_{\text{effective}} = G(1-\rho^2)/(1-G^2 \rho^2)$ . Example: if  $G = 10^{-0.09}$  (.9 db attenuation), and  $\rho = \sqrt{1/10}$  (1.92 VSWR), then  $G_{\text{effective}} = .783$  or 1.06 dB effective attenuation.

## 2.2 Increasing the Bandwidth

There has long been a desire for increased bandwidth to achieve better range resolution. In 1980, Gene E. Tallmadge, then at S.R.I., prepared a report "Arecibo 430 MHz Transmitter Enhancement Study". The objective was to evaluate the feasibility of modifications so that 180 degree phase changes can be transmitted at a baud width of  $0.2 \mu\text{s}$

with an attendant power output reduction of 3 dB or less - using the existing klystrons or modifying them. Tallmadge concluded that the bandwidth limitation at that time was due to the IPA (driver amplifier) and that, by changing to a wide-band IPA and re-tuning the final klystrons, the goal could be met. His data is shown below. Tallmadge estimated that the wide-band driver would have to supply 3.14 kW peak power. We now have a wide-band solid-state IPA, capable of 1kW drive power. The installation of this new driver amplifier made a noticeable improvement in bandwidth, but as of May, 2005, the klystrons have not been tuned for the maximum 2MHz bandwidth.

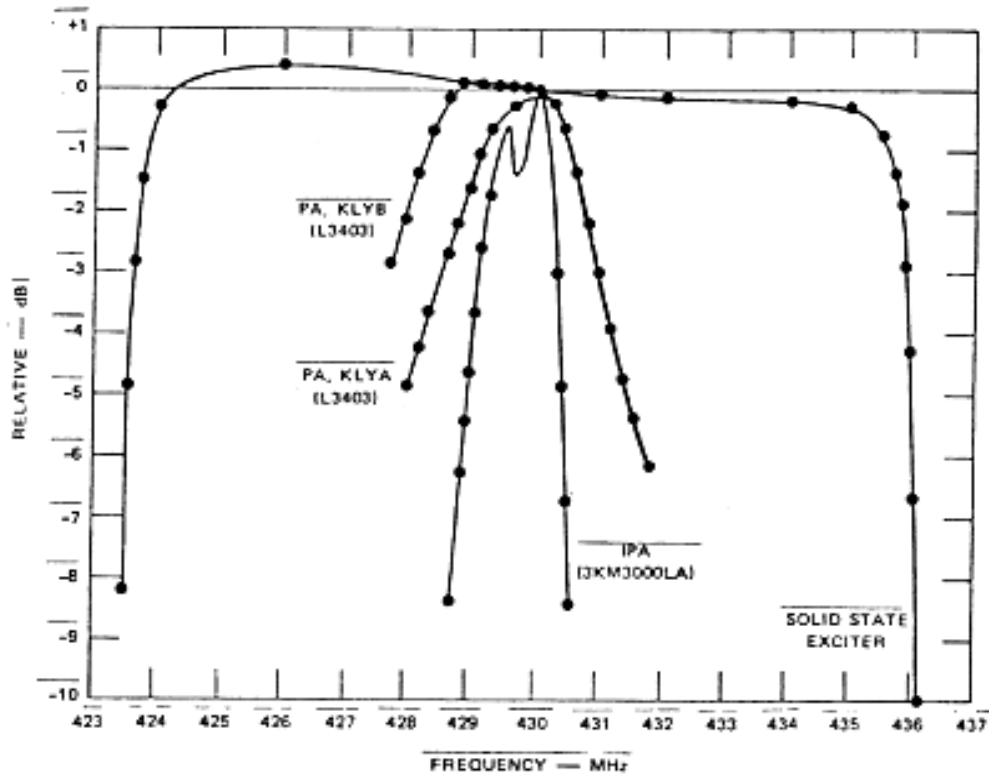

FIGURE 1 BANDWIDTH OF 430 MHz TRANSMITTER COMPONENTS

Transmitter Bandwidth Limitations as of 1980  
 IPA was the bottleneck at that time. PA can achieve 2 MHz bandwidth.  
 (figure from report by Gene Tallmadge)



### 3. Brief Description of the Transmitter

Three block diagrams on the following pages present an overall picture of the transmitter.

#### 3.1 RF Circuitry - Refer to drawing 430BLOK1

##### 3.1.0 Timing Generator

For testing purposes, this unit in the control console can generate the four pulses needed to control the transmitter: the *receiver protection* command, the *beam on* command, the *rf on* command and the *rf phase* command. But normally these commands are generated by a programmable pulse generator that is part of the computer data-taking interface. The program-generated pulses enter the timing generator as "Request pulses". Unless they violate restrictions put on duty factor, pulse length, etc, the requests are passed on, unaltered, as commands to the transmitter circuitry. Otherwise the timing generator modifies them to make them acceptable. When this occurs, lights on the panel of the timing generator indicate what restrictions are being violated.

##### 3.1.1 Exciter

The exciter circuitry is in the control console. Its output stage is a 20dBm amplifier. The output from this amplifier, 100mW peak, is pulsed on and off synchronously with the high-power modulator. The exciter can apply bi-phase modulation to the drive signal. No amplitude modulator is included in the exciter, although the subsequent IPA and PA stages are essentially linear amplifiers when they are not driven to saturation.

##### 3.1.2 Intermediate Power Amplifier (IPA)

The original IPA used a single Eimac 3KM3000LA external cavity klystron, capable of producing a peak power of 20 kW or an average power of 1Kw. The present IPA is a solid state amplifier capable of supplying 500W. A second identical amplifier is mounted in the IPA rack, together with hybrid combiners. The two amplifiers can be combined to supply 1000W of drive, if needed when the PA (power amplifier) klystrons are stagger tuned. These solid state amplifiers are pulsed on, like the high voltage modulator, just ahead of the RF pulse. A second-harmonic trap (shorted stub) is located at the output of the IPA. The IPA signal reaches the PA by way of a 1.5" coaxial transmission line.

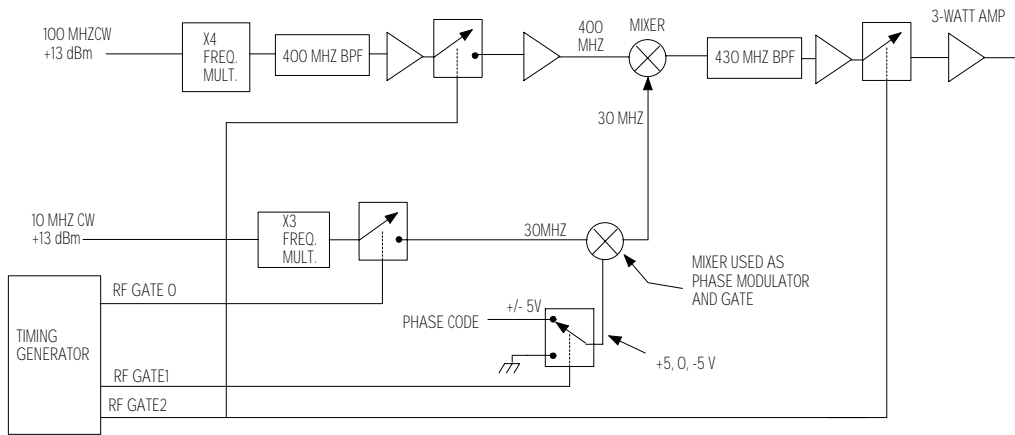
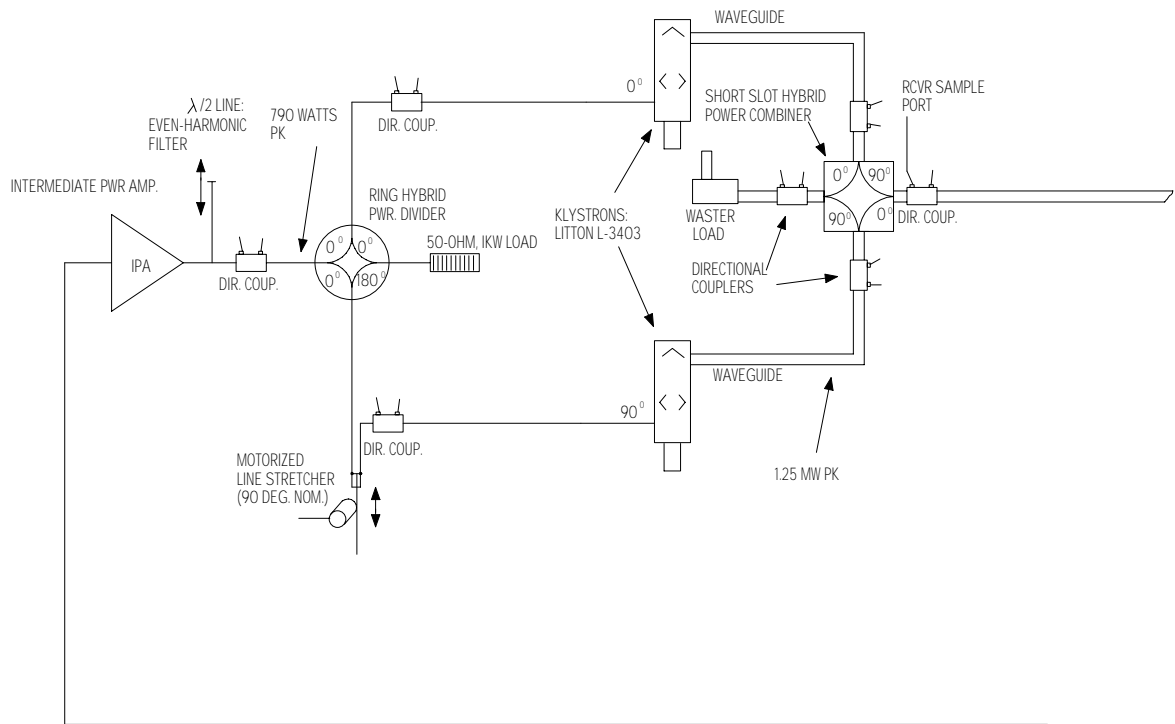

EXCITER & PULSE CONTROL (IN CONTROL CONSOLE)

## 430 TRANSMITTER BLOCK DIAGRAM PAGE 1 OF 6: DOWNSTAIRS RF SIGNAL PATHS

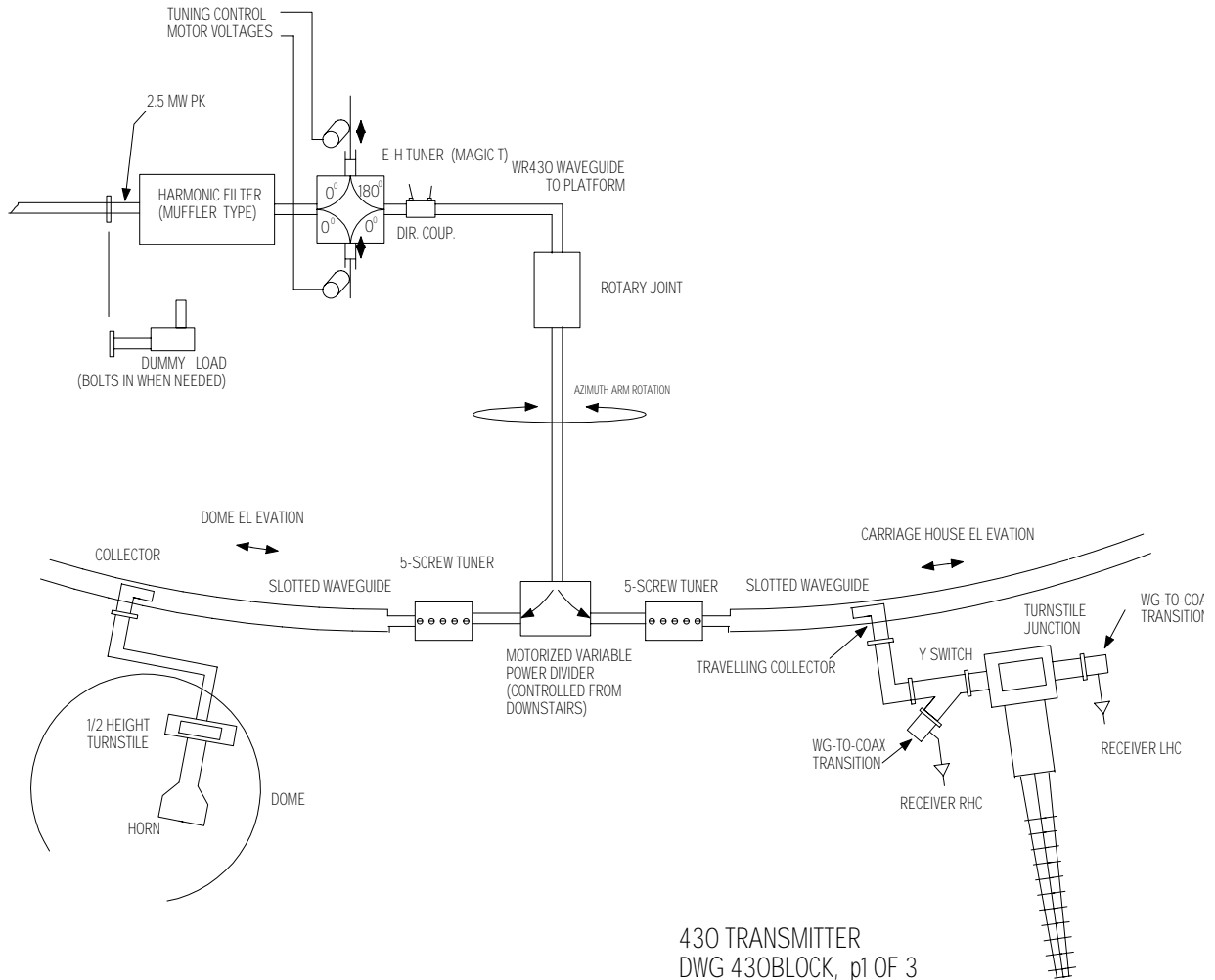

430 TRANSMITTER  
 DWG 430BLOCK, p1 OF 3  
 TITLE: BLOCK DIAGRAM  
 DRAWN 12-98 TO REPLACE J349C003  
 PAGE 1 OF 3: RF CIRCUITRY

430blok1.ecw jbh 12-02-98 re

430 TRANSMITTER BLOCK DIAGRAM  
 PAGE2 OF 6: UPSTAIRS RF SIGNAL PATHS

### 3.1.3 Power Amplifier (PA)

Two klystrons operate in parallel as a balanced amplifier with a coax power divider at the input and a waveguide 90-degree hybrid combiner at the output. The input power divider is actually a ring hybrid and the divided outputs have the same phase. However, one of these outputs is delayed the necessary additional 90 degrees by a remotely adjustable motor-driven transmission line "trombone". The isolated port on the output combiner is terminated with a "waster load". Nominally there should be no power dissipated in the waster if the trombone section is adjusted correctly but, if the two klystrons do not have identical output power, some wasted power is inevitable. If the phase is wrong by 180 degrees, all the power will be diverted to the waster instead to the antenna. Directional couplers allow the operator to monitor the total output power, the waster power, and the individual drive and output powers.

The Litton L-3403 and L-5773 internal cavity klystrons were developed for the BMEWS (Ballistic Missile Early Warning System) air defense radar system. Hundreds of these tubes were used at the three BMEWS sites - Thule (Greenland), Clear (Alaska), and Fylingdales (England). The L-3403 set records for reliability; many operated continuously up to ten years in BMEWS transmitters. The L-5733 was developed in the '80s as a high-efficiency variant of the L-3403; the efficiency went from 35% to around 45%. Arecibo has inherited surplus tubes of both types from the BMEWS stations at Thule and Clear. See Section 5 for the klystron specifications.

The klystron beam current is modulated, i.e. turned on only for the duration of each RF drive pulse. During the pulse, 35% of the beam power (beam voltage x beam current) is converted to useful RF output power and 65% is converted to wasted heat. The output power during the pulse is 2.5MW and the input power is  $2.5/.35 = 7.14\text{MW}$ . The average powers are 150kW and 429 kW, respectively. When there is no RF drive, 100% of the beam power is converted to heat. If the beam were not turned off between pulses, the input power to the transmitter would be  $7.14\text{MW}/.06 = 119\text{MW}$ . Pulsing the beam at a 6% RF duty factor reduces the input power to 429 kW, a considerable saving in power! (The klystrons, of course, cannot dissipate enough heat to run with the beam on continuously; their maximum duty factor is 6%).



Litton

L3403

Klystron cut open for display at Arecibo  
Note tuning plungers with bellows vacuum seals and  
cooling coils wrapped around drift tube in sections between cavities.

Beam pulsing is done by means of a "mod anode" control element built into each klystron. When the mod anode is biased about halfway between the cathode and anode voltages, the beam current is turned on. When the mod anode is biased slightly (5kV) more negative than the cathode voltage, the beam is completely turned off. The complete turn off is needed, even in the absence of RF drive, to prevent the klystron from generating noise, some of which would leak through the turnstile junction diplexer and into the receiver. (See specifications; even with the beam 'off', the transmitter noise power output could be as large as 750 Kelvins). The modulator for the PA is a high-power vacuum tube switching circuit that connects the mod anodes (which are connected in parallel) to a -55kV "half voltage" tap on the beam power supply or to the chassis of the "buffer deck" which is at a potential 5kV more negative than the cathodes. The modulator is described in detail in Section 13. For high voltage insulation, a fiber optic link to the floating deck is used to turn on the beam. A second fiber optic link, to the buffer deck, pulses the buffer deck for 2 microseconds following the beam pulse to bring the mod anodes back down to cathode potential, turning off the beam.

#### 3.1.4 Harmonic filter, Antenna tuner and waveguide

A high-power “waffle-iron” or “muffler type” waveguide filter provides dissipative attenuation for any power at the second and higher harmonics. Like the klystrons, this filter was developed for the BMEWS radars. The harmonic filter is followed by an antenna tuner in the form of a waveguide magic-T hybrid with motor-driven stubs on two of its four ports. This so-called *EH tuner* (see Section 19) can be adjusted to present the transmitter with a reflectionless load for any reflection coefficient appearing at the downstairs end of the waveguide. The tuner is followed by 1500 feet of WR2100 waveguide that run from the control building to the platform. When considerable EH tuner correction is needed, it is because there are large reflections from the platform-mounted components. Although the tuner eliminates standing waves on the transmitter side, reflections from the platform will, of course, result in standing waves in the 1500 ft. run of waveguide. But, as is the case in all transmission line situations, if the VSWR on the transmission line is less than about 2:1, the power dissipated by ohmic loss in the line is an acceptably small fraction of the total power.

### 3.1.5 Platform RF components

The waveguide passes through a rotary joint at the top center of the azimuth arm. It then proceeds down to the bottom of the arm to the continuously adjustable two-way power divider, described in Section 20. One output of the divider supplies power to the carriage house while the other output supplies power to the Gregorian dome. This *dual-beam* operation is equivalent to two radars pointing in different directions. Connections from the power divider to the carriage house and the dome require the equivalent of telescoping waveguides to accommodate motion along the elevation track. This is accomplished by using a slotted waveguide fixed to the bottom of the azimuth arm. The slot (which has negligible radiation loss) points downward. A pickup probe extends from the carriage house up into the slot. The probe is actually a special waveguide elbow with wheels. This "collector" travels along inside the slotted waveguide. It has a half-height output port that passes through the approximately 8" wide slot. A 5-probe tuner at the junction of the WR2100 and the slotted waveguide eliminates reflections that would be produced at this junction. Power from the collector enters the carriage house through a length of corrugated waveguide and is connected to a turnstile junction. The lengths of the side arm shorts on the turnstile are adjusted so that *a.* no power is transferred from the transmitter port to the opposite port (the receiver port) and *b.* that the power leaving the antenna port has circular polarization. When the transmitted signal is reflected by a radar target (the ionosphere, the moon, etc.) the echo returns with the opposite circular polarization. The turnstile routes this echo power to the receiver port. This turnstile junction/circular polarization setup is therefore "self diplexing" - no additional hardware is needed to switch the antenna back and forth between the transmitter and the receiver.

### 3.2 High Voltage Power Supply

An adjustable power supply furnishes up to 120 kV at 4.4 amps. The voltage charges the 37.2 uF capacitor bank. When the transmitter is pulsed, the klystrons pull high current from the capacitor bank. The power supply is behind a locked door in the high voltage vault. The key that unlocks the vault door is the key that operates the power switch on the transmitter console. The key cannot be removed from the console unless the power switch is in the Off position.

#### 3.2.1 Crowbar

The Crowbar circuit provides path by which the nearly all the charge in the capacitor bank can be dumped to ground, rather than through an arc inside one of the klystrons. Two fault conditions indicating an internal arc can trigger the crowbar to fire: excessive pulse length and a sudden increase in body current. (Note that body current might be called 'ground fault' current. Besides true body current within the klystron, leakage current from any part of the B- supply to ground will be read as body current and will trigger the crowbar). The term "crowbar" was probably adopted to suggest a heavy metal bar used to produce a sudden short.

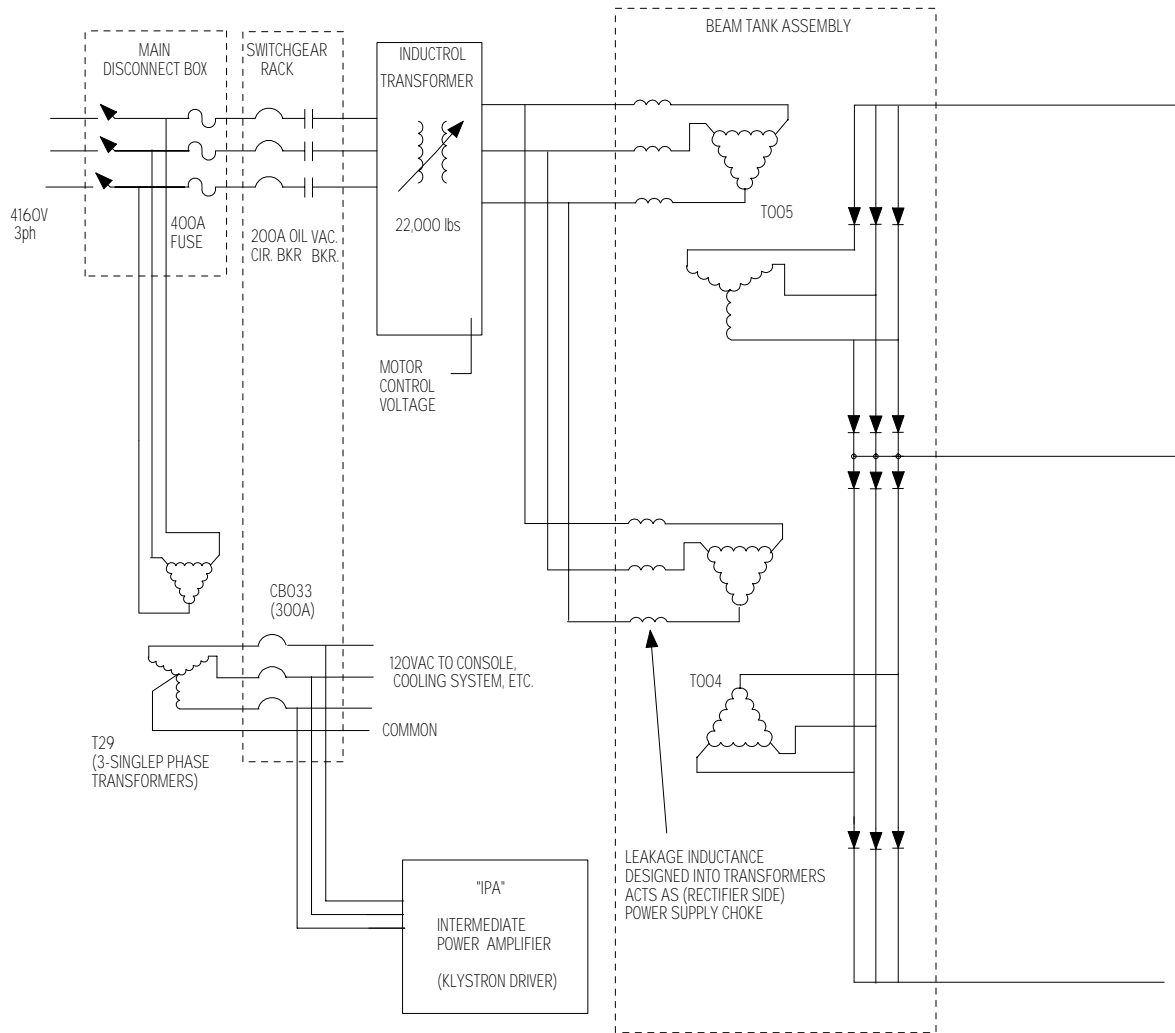

430 TRANSMITTER BLOCK DIAGRAM  
HIGH VOLTAGE CIRCUITRY P1 of 3



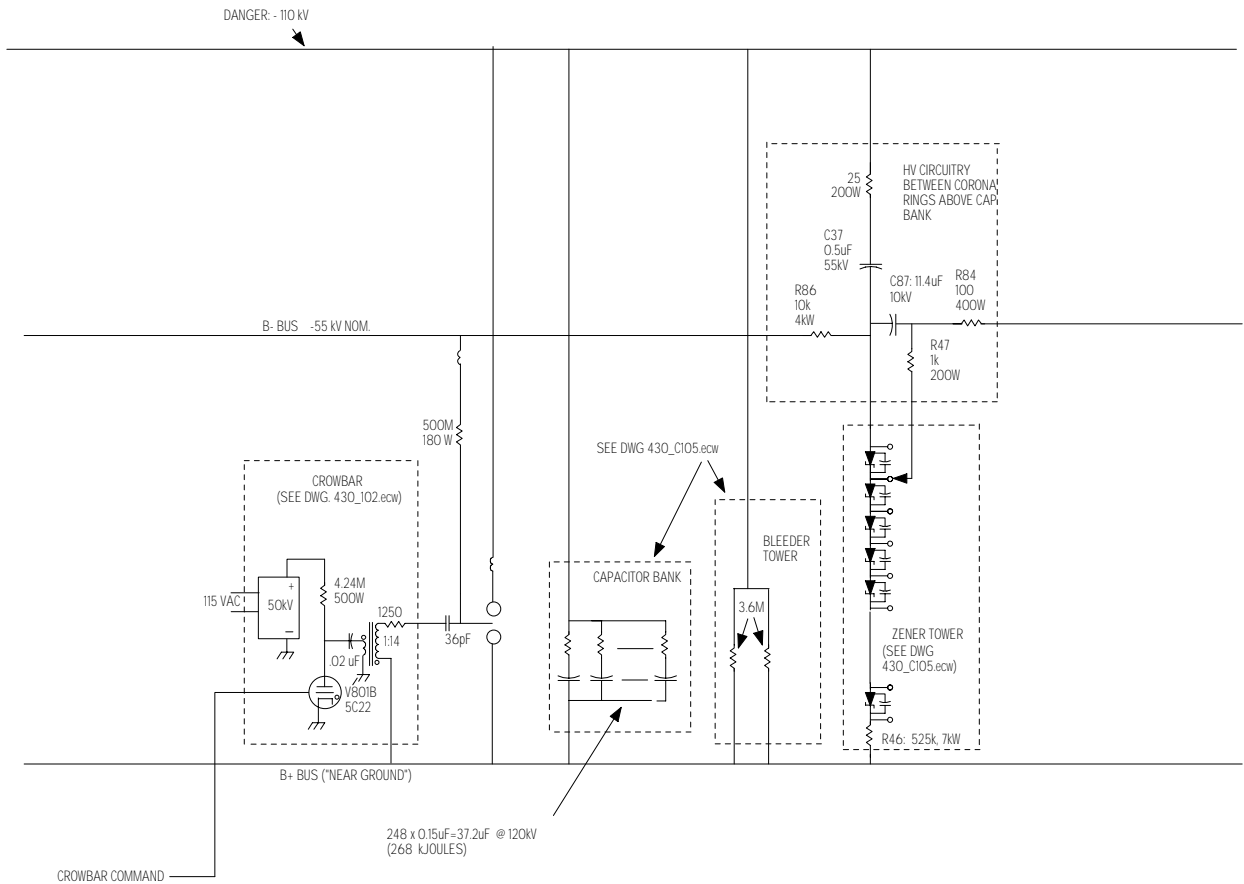

430 TRANSMITTER BLOCK DIAGRAM  
HIGH VOLTAGE CIRCUITRY P2 of 3

430blocl.ecw jth 11-30-98 rev 1.

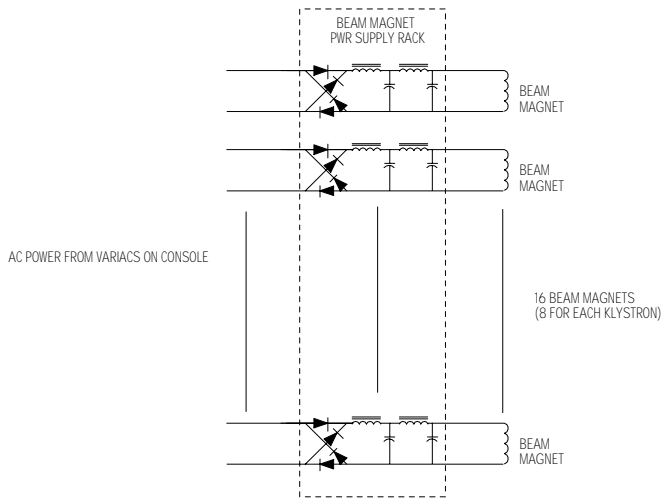
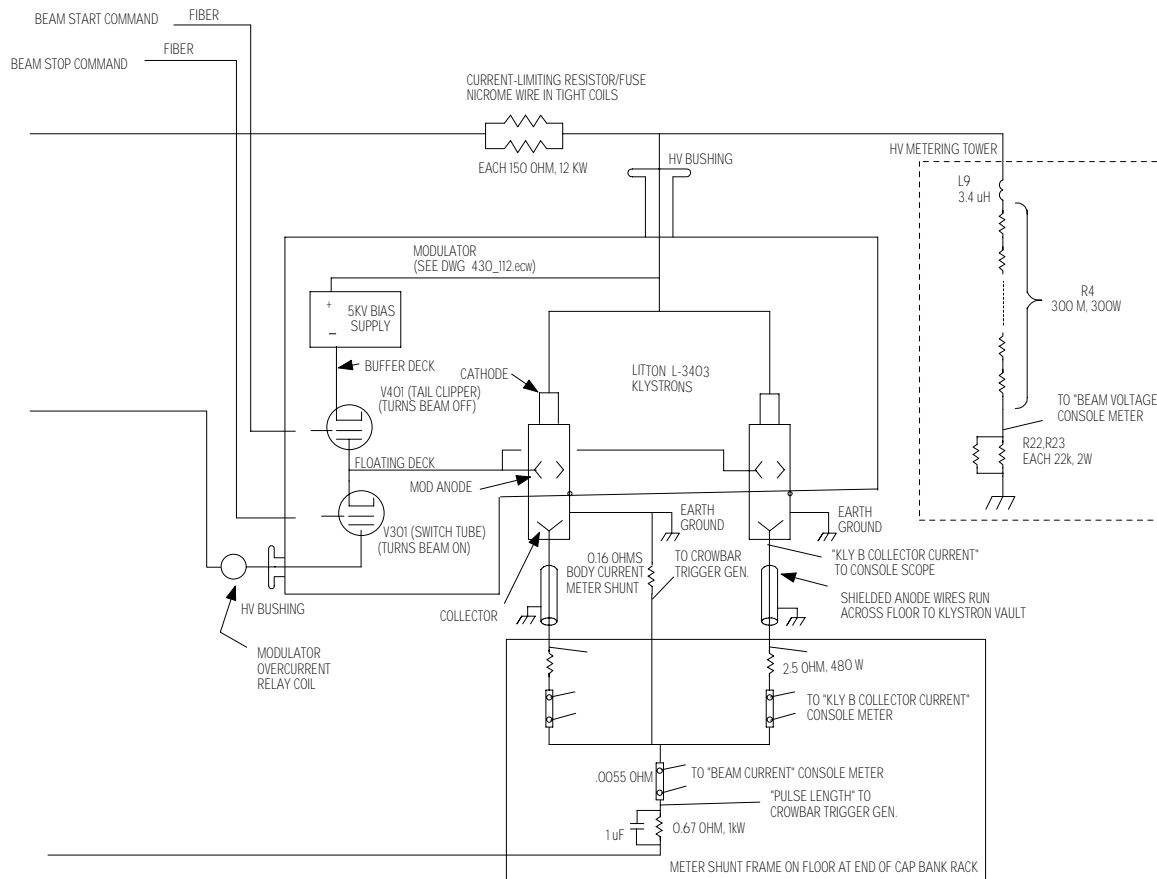

430 TRANSMITTER BLOCK DIAGRA  
HIGH VOLTAGE CIRCUITRY P3 of 3

430bloct.ecw jbh 11-30-98 rev

### 3.3 Cooling system: The cooling system is shown below in block diagram form

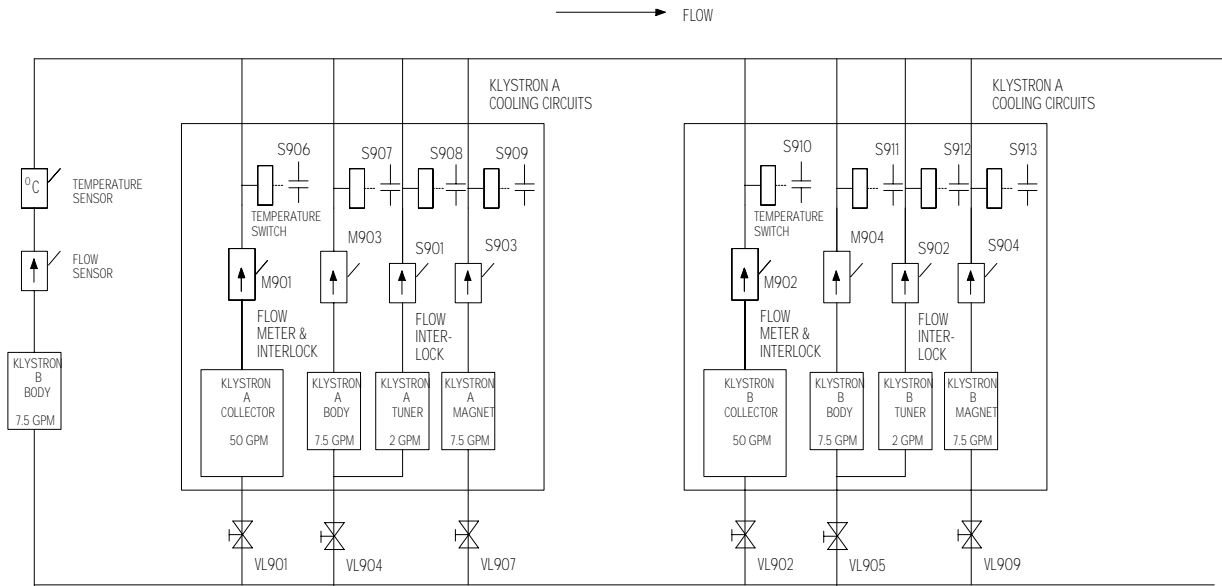

### SOLENOID VALVE ELECTRICAL CIRCUITRY

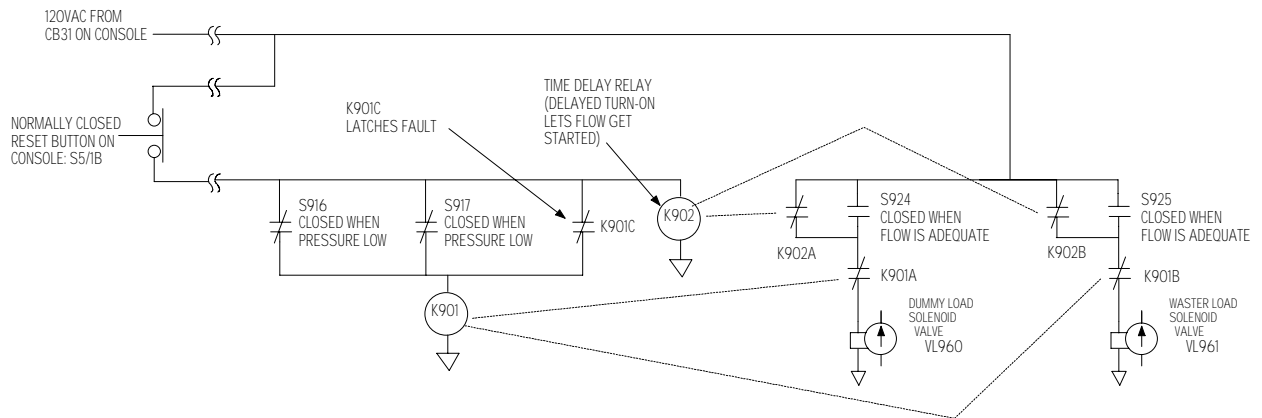

430 TRANSMITTER BLOCK DIAGRAM  
COOLING SYSTEM PAGE 1 OF 2

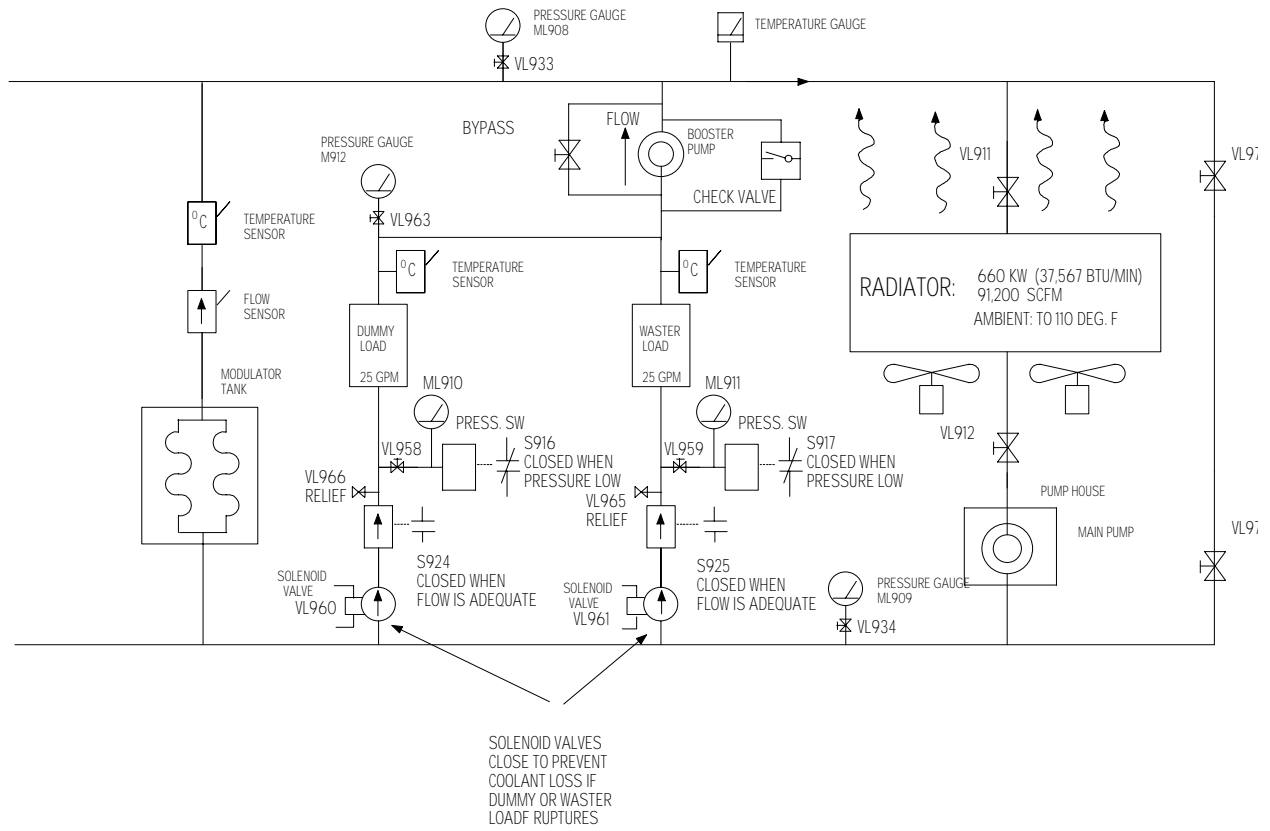

FLOW METER/INTERLOCK DETAIL

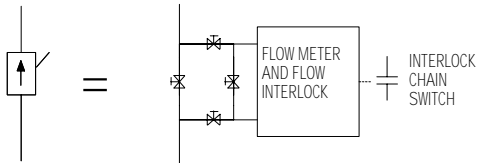

430 TRANSMITTER  
DRAWING 430BLOCK  
TITLE: BLOCK DIAGRAM SEE ORIGINAL DWG D-3  
DRAWN 11-98 TO REPLACE J349C003  
PAGE 3 OF 3: COOLING SYSTEM

430blocksw jbh 12-02-98

430 TRANSMITTER BLOCK DIAGRAM  
COOLING SYSTEM PAGE 2 OF 2

WATER STORAGE TANK  
APPROX 25 FT OFF THE GROUND

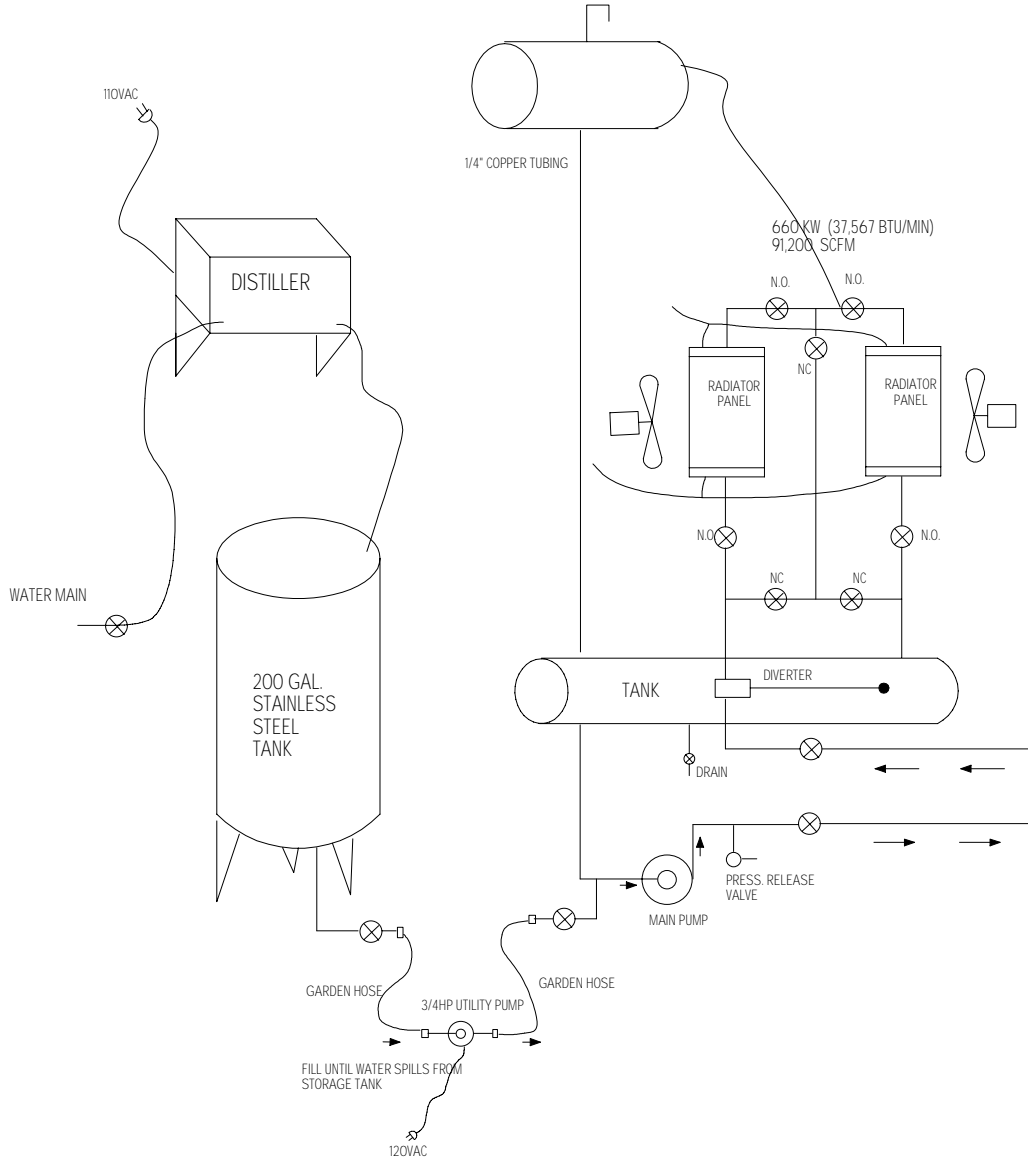

# HEAT EXCHANGER ON OUTDOOR PAD

430 TRANSMITTER  
DRAWING 430BLOC1  
TITLE: BLOCK DIAGRAM  
DRAWN 11-98 TO REPLACE J349C003  
PAGE 4 OF 4: HEAT EXCHANGER

430bloc1.dwg jgh 12-02-98  
rev. 2-24-03 jgh



Water storage tank on side of building. Note the waveguide, leaving the EH tuner on the mezzanine and heading down to loop beneath the road.



Heat exchanger on pad next to oil storage tanks.

### 3.4 Modification History

During the original installation of the transmitter, the crowbar circuit was redesigned (though the original manual was not updated). The Marx Generator (voltage multiplier) that supplied the crowbar ignition voltage was eliminated. A sharp point was substituted for the ignition ball. A resistor voltage divider was used to bias this point at half the beam supply voltage. Later this divider was eliminated and the point was biased from the halfway tap (-55kV nom.) of the beam supply.

In 1972, the vacuum tube HV rectifiers were replaced with silicon rectifier stacks. Filament transformers and regulators for the tube rectifiers were removed.

In 1985, circuitry was installed to limit further the initial inrush current in the klystron filaments. This consists of a choke in series with the primary of the filament transformer. A time delay relay shorts the choke after the delay.

In 1986, the original bank of capacitors was replaced with new non-PCB capacitors. While the original capacitor bank could be strapped in two configurations (110kV and 150kV, the new bank has a fixed configuration: 120kV max. The low-level RF and pulse circuits have evolved throughout the life of the transmitter.

In 2002, the buffer deck fiber optic control was simplified. A fixed 10 usec pulse is sent to the buffer deck after the floating deck is turned off. Before, identical command pulses were sent to each deck. The buffer deck turned itself on when the pulse was off AND the voltage of the floating deck was sensed to be high. Any accidental interruption of the link to the buffer deck would cause shoot-through (both decks on simultaneously). This modification also eliminated the need for the troublesome high voltage divider needed for the buffer deck to sense the floating deck potential.

In 2005, a second fiber was provided to each deck. These fibers directly operate the clamp tubes that prevent 'shoot through', simultaneous conduction in the pull up tube (floating deck switch tube) and the pull down switch tube. Originally, each clamp tube was operated automatically from a signal derived on its respective deck. Both decks had to be operating to produce the clamping action. With the externally supplied fibers, the decks can be operated independently for easier testing and troubleshooting. The original clamp circuits were OR'd with the new fiber signals, to provide back-ups for the fibers.

## 4. Operating Instructions

The transmitter operation is very simple. The only tuning needed during the turn-on sequence is adjustment of the waveguide tuner in order to minimize the reflected waves seen by the klystrons.

### 4.2 Turn-on sequence

1. Push the *IPA SYSTEM ON* button. The green *IPA SYSTEM ON* indicator lamp above this button should light. (Note, as of May 2005, the new IPA must still be turned on at its rack in the transmitter room).
2. Push the *PA SYSTEM ON* button. The green *PA SYSTEM ON* indicator lamp above this button should light. A series of relays should be heard as they are energized. The rows of neon lights at the left hand lower apron of the console should start lighting and the magnet current meters should show current.
3. Fifteen minutes after pushing the *PA SYSTEM ON* button, the orange *PA HV READY* indicator lamp will come on telling the operator that the transmitter is ready for operation. Set the *SCOPE OUTPUT* selector to *MOD ANODE* and push the *PA RESET* button. A square pulse should be seen on the scope.
4. Push the *PA HIGH VOLTAGE ON* button. The red *PA HIGH VOLTAGE ON* indicator lamp will light. Use the *PA RAISE LOWER* lever to raise the PA voltage to the value required: 98 kV for 2.5 MW of RF output power.
5. The motorized E-H tuner can be used to minimize the power reflected back to the transmitter.  
Operate the two (interactive) controls to minimize the reflected power reading on the bolometer.



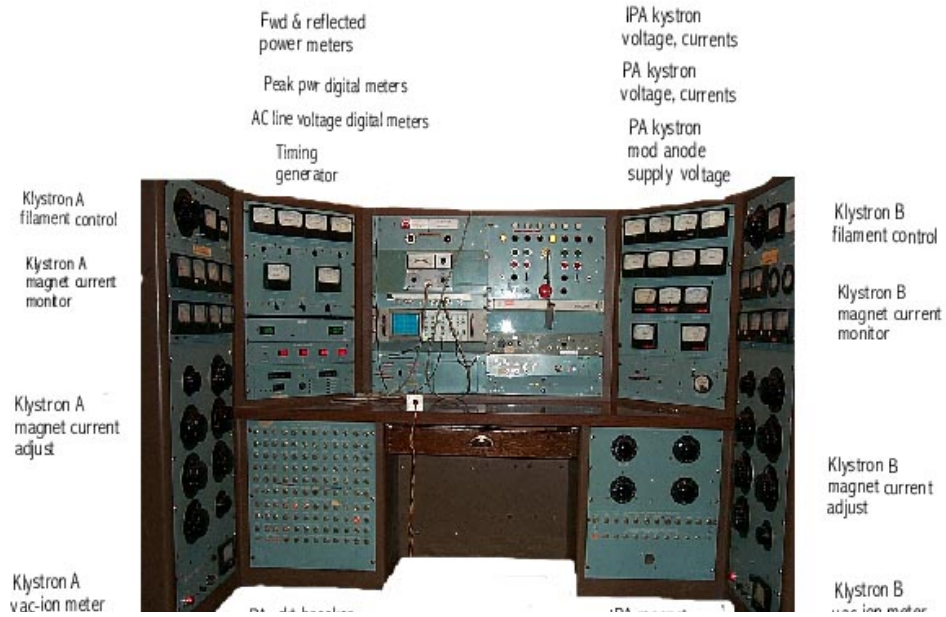

Face view of control console

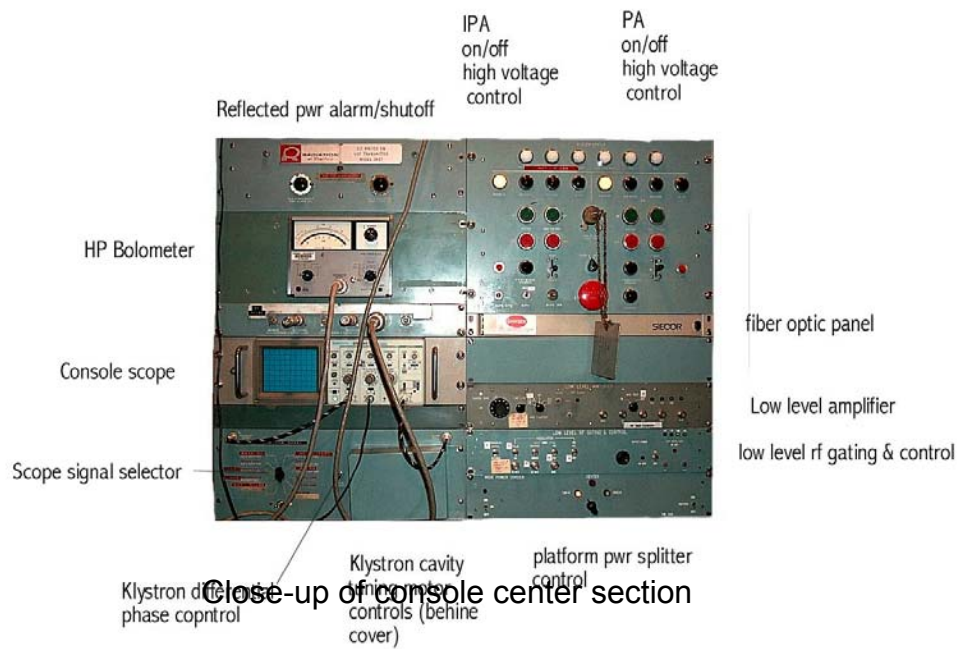

USED TO SET DRIVE  
LEVEL TO IPA.

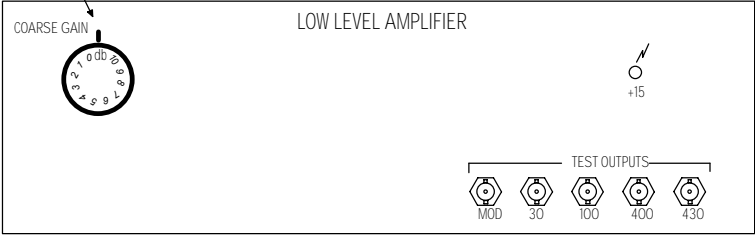

NOTE: NORMAL SWITCH SETTINGS SHOWN IN BOLD

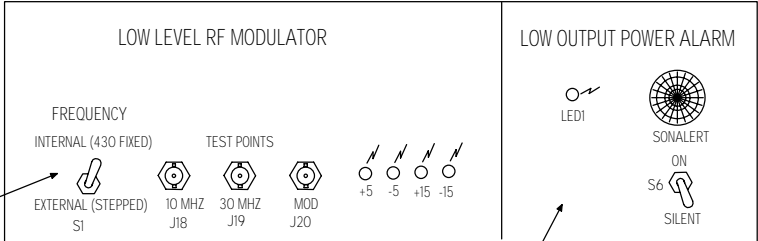

NORM: OUTPUT FREQUENCY =  
"10 MHz" (FROM J13 ON REAR PANEL) X 3  
+ 4 X "100 MHz" (FROM J2 ON LOW LEV. AMP REAR PANEL)

STEPPED: OUTPUT FREQUENCY =  
"30 MHz" (FROM J11 ON REAR PANEL)  
+ 4 X "100 MHz" (FROM J2 ON LOW LEV. AMP REAR PANEL)

ALARM TO AWAKEN OPERATOR  
WHEN TRANSMITTER OUTPUT POWER IS LOW



Modulator

disable:

small slide switch at the right  
of the modulator high voltage supply meter

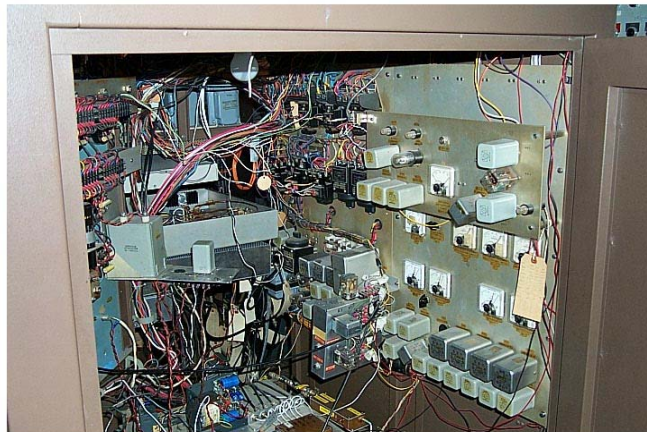

Door open on right-hand side of control console to show interior meters

### 5.01 Litton L-3403 Klystrons

From the Litton Installation and Operation Manual:

"The L-3403 Klystron is a four-cavity, modulating-anode, pulsed klystron amplifier which can be mechanically tuned to amplify any frequency within the range from 400 to 450 MHz.

The tube will produce a peak power output of 1.25 MW at an average RF power output of 75

kW at a 0.06 duty factor with a minimum power gain of 35 dB. The efficiency of the tube is 35%, so 75kW output power requires 223kW of beam power. When the proper voltages are applied to the tube, a beam of electrons is formed at the cathode end of the tube and travels axially through the tube to the collector. The beam is maintained in its cylindrical shape by an axial magnetic field produced by eight external electromagnets. The beam passes through four internal cavity resonators. With RF power applied to the input cavity, and with the four cavities tuned properly, the amplified signal is available at a coaxial output connector. After the electrons pass through the cavities, they impinge on the inner surface of the collector and the remaining beam energy is converted to heat which is carried away by the liquid coolant.

The tubes are 10 feet long with a principal diameter of 17.5 inches. They weigh approximately 885 pounds. The coolant flows are 50 gpm for the collector, 7 gpm for the body, and 1 gpm for the tuners. At these flow rates the pressure drop across any of the three cooling circuits should not exceed 50 psi. Maximum inlet pressure should never exceed 100psi and the temperature at the outlet must be not exceed 70 deg. C, whichever is less. The circuits should not be operated in series. Air cooling of the coaxial output horn is required to prevent overheating the metal-to-ceramic seals. Approximately 20 cfm is sufficient.

The heater requires a voltage of 30 volts and can be either dc or ac since the cathode is indirectly heated. At 30 volts the current should be between 12A and 15A. Since the cold heater resistance is 0.20 ohms, some provision must be made to prevent a turn-on surge from exceeding the maximum limit of 22.5A.

High voltage should not be applied unless the vacuum is better than  $5 \times 10^{-6}$  mmHg. The mod anode is the beam current control electrode, used for beam pulsing. Full beam power is obtained with the mod anode is at approximately midway between the anode and cathode voltages. The mod anode must never exceed 60% of the anode-to-cathode voltage.

The tube is designed to operate with a peak input beam power of 4.01 MW. With this input power, the tube is designed to operate with a maximum cathode pulse length of 2.1 ms at a PRF of 30 Hz. The start of the RF drive pulse should coincide with the flat portion of the dc pulse, i.e.

when the beam is fully on.

Refer to the Litton Industries L-3403 Klystron Installation and Operation Manual for complete details. Appendix B from that manual is copied below:

From Litton Manual, Appendix B  
L-3403 Klystron Maximum Operating Values

1.	Filament	
	a. Surge Current	22.5 amperes (max)
	b. Heat Time	15 minutes (min)
	c. Voltage (operating)	30 volts (adjust)
	d. Current (operating)	12 to 15 amperes
	e. Power (at tube)	450 watts (max)
2.	Anode Voltage (Eb)	120 kilovolts (max)
3.	Cathode Current	27 amperes (max)
4.	Mod-anode Voltage	Not to exceed 60% Eb Nominal 50% Eb
5.	Pulse Width	2.1 milliseconds (max)
	PRF	60 max. (See Note 1)
	Beam Duty Factor	6% (max)
6.	Coolant - Distilled Water	
	a. Collector Flow	50 gpm (min)
	b. Body Flow	7 gpm (min)
	c. Tuner Flow	1 gpm
	d. Output Transition Air Flow	250 cfm (min)
	e. Hydraulic Pressure	50 psi drop 100 psi max.
	f. Output Horn	20 cfm approx.
	g. Electromagnet - (See Note 2 below)	
7.	Focus Coil Settings	
8.	R.F. Drive Level	
	a. Average	24 watts (max)
	b. Pulse Peak	400 watts (max)
9.	Body Current	.250 amperes (max)

Note 1 - PRF X pulse width not to exceed maximum duty cycle of 6%

2 - Determine flow from Electromagnet instructions

## 5.02 Litton 5773 Klystrons

The L-5773 is an improved L-3403, designed for higher efficiency. All our L-5773s were obtained surplus from the decommissioned BMEWS transmitters at the Clear, Alaska Air Station. We have several copies of the original Litton Installation and Operation Manual for the L-3403, but the only documentation we have on the L-5773 is some acceptance test data. That data, from serial no. 0046, 11/8/2000, is copied below, and is quite complete. The first set of data was for

maximum power operation . The second set of data is for 80% of maximum rated power and reduced duty cycle, which was the mode of operation used at the BMEWS stations.

### **Maximum Power Tests 445 MHz**

Flow rates for 50psi differential pressure:

Collector: 50 GPM (50 min),

Body: 8.1 GPM (7 min)

Tuner: 6.0 GPM (1 GPM min)

Hydrostatic test @ 100 PSI: no leaks

Collector-to-body body resistance: 1k Megohms

Temperature, Top of RF outbox coax, 1" from body 37 deg. C (180 deg. C max)

Emission  $\Delta I_k$ : 0.5 (10% Max)?

Filament voltage 17 Volts

Filament current 13.3 Amps

Heater power 17 x 13.3 - 359W (405 W max)

Focus Coil Currents (2-7.5A)

#1: 1A; #2,3,4: 5.0A; #5: 4.8A; #6: 6.0A; #7: 4.0A; #8: 6.0A

Beam pulse length 2100usec (maximum allowed)

PRF 30Hz (60Hz max) [? No such limit was specified for the L-3404. We often run a 1kHz PRF.]

Duty factor: 6%

RF input pulse length 2000usec (maximum allowed)

Anode voltage 95kV (maximum rated anode voltage is 98kV)

Mod anode voltage 48.5kV= 51% anode voltage (nominally 50% of anode voltage; 60% max)

Cathode current 2.02A (2.4A max)

RF input power 41.7W pk (400W pk max)

RF output power **1.39 MW** pk

Gain: 45.2dB (35 dB min)

Efficiency: 47.8% (40% min)

Mod Anode current 2.5mA (12MA max) (must mean Modulator Supply Current)

Body current (Avg) 164mA (500mA max)

### **80% Maximum Power Tests 445 MHz (BMEWS operating parameters)**

Beam pulse length 2100usec (maximum allowed)

PRF 27Hz (60Hz max) [? No such limit was specified for the L-3404. We often run a 1kHz PRF.]

Duty factor 5.4%  
 RF input pulse length 2000usec (maximum allowed)  
 Anode voltage 90kV (maximum rated anode voltage is 98kV)  
 Mod anode voltage 46.8kV= 52% anode voltage (nominally 50% of anode voltage; 60% max)  
 Cathode current 1.71A (2.4A max)  
 RF input power 49.2W pk (400W pk max)  
 RF output power **1.15 MW** pk  
 Gain: 43.7dB (35 dB min)  
 Efficiency: 44.38% (40% min)  
 Mod Anode current 2.5mA (12MA max)  
 Body current (Avg) 127mA (500mA max)

### 5.1 Klystron Frequency Shift

When the 430 MHz transmitter is used to make Doppler velocity measurements, a correction must be added to the apparent Doppler shift because the output frequency of the klystron amplifier is slightly lower than input frequency (430 MHz). This is a result of the beam velocity modulation used in the klystron and the droop in accelerating voltage that occurs as the capacitor bank is discharged. We can calculate the frequency shift as follows:

Suppose that a concentration of electrons leaves the input cavity at time  $t_1$ . Its time-of-arrival at the output cavity will be  $t_1 + D/v$ , where  $D$  is the length of the drift tube (about 2m) and  $v$  is the electron velocity (about  $c/2$ ). One period later, at  $t_1 + 1/430E6$ , the next concentration of electrons leaves the input cavity. Its time of arrival will be  $t_1 + 1/430E6 + D/(v + \Delta v)$  where  $\Delta v$  is the amount the beam velocity has changed in one period. The error in arrival times (w.r.t. 430MHz) is given by

$$\Delta t_{arrival} = D/(v + \Delta v) - D/v \approx -D\Delta v/v^2.$$

The frequency error is given in terms of this arrival time error by

$$\Delta f/f = -\Delta t_{arrival}/(1/f) = -f \Delta t_{arrival}$$

Therefore we can write

$$\Delta f = -f^2 \Delta t_{arrival} = f^2 D\Delta v/v^2.$$

Since  $mv^2/2 = qE$ , where  $E$  is the accelerating voltage, we have  $\Delta v/v = \Delta E/2E$  and

$$\Delta f = f^2 D\Delta E/(2Ev).$$

The voltage change in one cycle,  $\Delta E$ , is given by  $-I(f)/C_{PS}$  where  $C_{PS}$  is the value of the capacitor bank,  $37\mu\text{F}$ , and  $I$  is the beam current. If we assume the output power is  $2.5\text{MW}$ , the efficiency is  $35\%$ , and the power supply voltage is  $100,000$ , the current is given by  $I = 2.5 \times 10^6 / (0.35 \times 100,000) = 71\text{A}$ . Therefore  $\Delta E = -71(1/430 \times 10^6) / 37 \times 10^{-6} = -.0045$ .

Since the electron total energy is given by  $m_0 c^2 / \sqrt{1-v^2/c^2}$  and  $m_0 c^2 = .511\text{Mev}$ , the velocity can be written as

$$v = c \sqrt{1 - \left( \frac{.511,000}{E \times 511,000} \right)^2}$$

When the voltage is  $100,000$ , the velocity is  $v = .55c = .55 \times 10^8 \text{ m/s}$ .

Using these values for  $\Delta E$  and  $v$ , we find that

$$\Delta f = - (430 \times 10^6)^2 \times .0045 / (2 \times 100,000 \times 5 \times 10^8) = 50.4 \text{ Hz}$$

This corresponds to a Doppler velocity of

$$v_{\text{DOPPLER}} = c \Delta f / (2f) = 50.4(3 \times 10^8) / (2 \times 30 \times 10^6) = 17.6 \text{ m/s}$$



## 6. Final amplifier RF circuitry

The detailed circuit diagram for the RF connections in final amplifier is found on page 2 of Drawing No. 430\_107, the monitoring schematic. The final amplifier consists of an input power splitter which supplies drive power to the two klystrons and an output power combiner, a waveguide sidewall coupler made by MDL. This output combiner is a 4-port *hybrid junction*. The klystrons feed two of the ports. The third port is connected to the antenna, via a tuner and about 1500 ft. of WR2100 waveguide. The fourth port is connected to a load, the *waster load*.

Assuming that the waster load presents no reflection and that the tuner has been adjusted to remove any reflection at the antenna port, each klystron will look into a matched termination, no matter how the other klystron is tuned. This is the essential advantage of using a hybrid combiner; it allows the tubes to run in “parallel” without any mutual interaction.

When the relative phases of the klystron output waves are correct and the amplitudes are equal, all the power is sent to the antenna and no power is dissipated in the waster load. This requirement is not strict. If, for example, one klystron puts out twice as much power as the other (ratio of the amplitudes is .707) and the phase error is 20 degrees, 94% of the total power reaches the antenna and only 6% is dissipated in the waster load. Of this 6%, half is due to the phase error and half is due to the amplitude error. Note however, that if the phase error approaches 180 degrees, the power will be sent to the waster load rather than to the antenna. (This allows the waster to be used as a dummy load; one merely changes relative drive phases by 180 degrees).

The input power divider is also a hybrid junction; if there is no reflection from the driver amplifier (IPA) and no reflection from the small waster load on the input hybrid, any power reflected at the input of either klystron will never reach the input of the other klystron. As with the output circuit, the hybrid isolated the klystrons from each other so that there will be no interaction when the input cavities are tuned.

Both the input and output hybrids are 90-degree hybrids (*quadrature hybrids*), so the relative phases at the klystron inputs and outputs is nominally 90 degrees. The use of 90-degree hybrids, rather than 0 or 180 degree hybrids, has the advantage that the driver sees a reflectionless load, even if the klystron inputs are reflective, assuming that the klystrons have identical reflection coefficients. (This is also true at the output side; any wave reflected from the platform back down to the transmitter will be dissipated in the output waster load. However, the EH tuner between the output hybrid and the transmission line is adjusted so that no reflection arrives back at the output hybrid).



Lead walled vault contains the two klystrons. The access door is open. Input splitter (ring hybrid) is partly visible at the bottom left of the door behind its waster load. Above the waster load is the motor driven trombone section used to adjust the relative phases of the klystron drive signals.

Waveguide hybrid output combiner fed by corrugated waveguide sections from the top of the klystron vault. The coaxial output of the klystrons is converted immediately to waveguide.

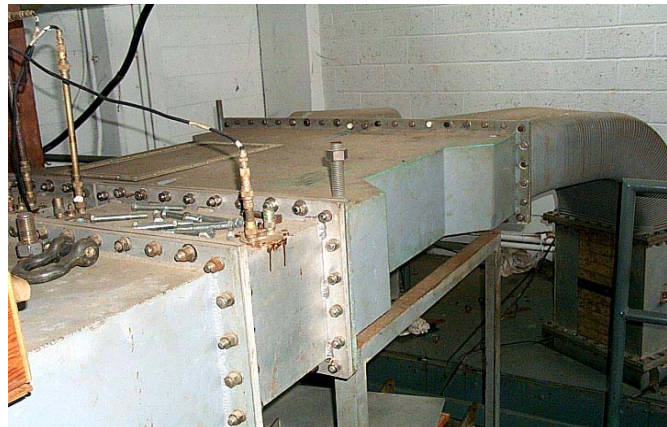

The input hybrid is actually a 180 degree hybrid (a coaxial “rat race”), but an extra 90-degree length coax at one of its outputs makes it effectively a 90-degree hybrid. This extra length is adjustable, a motorized trombone section. From the transmitter console this phase is fine tuned to minimize the power dissipated in the waster load. This adjustment allows compensation for phase error in the input and output hybrids and for relative phase shift between the klystrons due to non-identical tuning or operating conditions. The spring-loaded switch to shorten/lengthen the trombone is located at the transmitter console on the panel under the oscilloscope.

Both klystrons have four mechanically-tuned resonant cavities. All eight cavities are fitted with remotely-controlled tuning motors. The control levers for these motors are next to the trombone adjustment lever. They are normally covered by a metal box, as they are adjusted only when a klystron is replaced. Raise these paddle switches to increase the cavity resonant frequencies. Lower these paddle switches to decrease the cavity frequencies.

Meters on the console display reflected power at the input and outputs of each klystron, at the waster load, and at the output of the output combiner. These meters all use diode detectors mounted on directional couplers in the waveguides.

Other console meters indicate the beam current in each klystron, the total beam current, the total body current, the beam voltage, and the voltage tap for the modulator (approximately half the beam voltage).

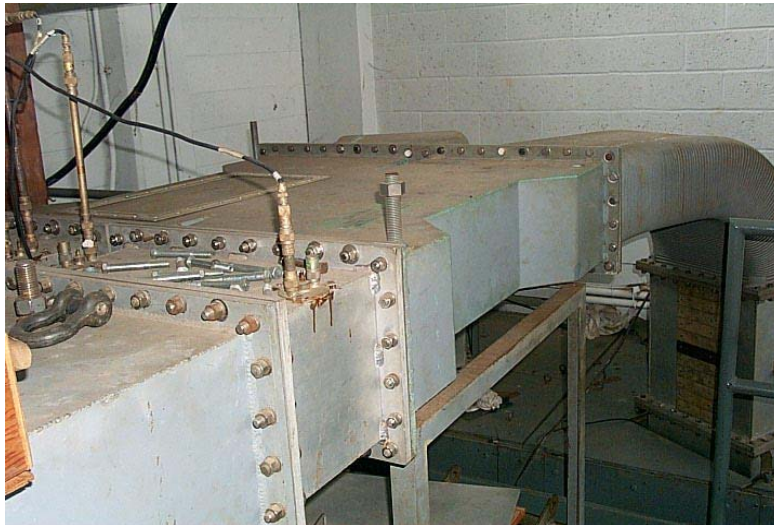

90-degree Hybrid Output Combiner

## 7. Harmonic Filter

The waveguide filter on the mezzanine absorbs second-harmonic energy. It is known as a “leaky wall” or “muffler” filter, and was designed and built by General Electric, primarily for the BMEWS radars, which used a Section 1 Filter in series with a Section 2 Filter. We have only a Section 1 unit, the 2nd harmonic absorber. (Section 2 absorbs the 3rd and 4th harmonics). This filter consists of a length of WR211 waveguide whose four walls have slotted openings, too short for 430 MHz leakage, but long enough to pass 860 MHz. Tapered absorbing structures (asbestos cement with a conductive coating) do the absorption. Aluminum boxes support and protect the absorbers and give the filter its cruciform cross-section. See the original General Electric manual for more information, as well as a GE reprint “Harmonic Suppression by leaky Wall Waveguide Filter” by Vernon G. Price, Richard H. Stone, and Viktor Met. This paper includes an extensive bibliography.



Second-harmonic filter, on the mezzanine, following the output combiner. The output of the filter (right side in the photo) feeds the EH tuner, a magic-T hybrid with motorized shorts in two of its four arms.

## 7.1 Antenna Tuner

Various mismatches in the platform-mounted waveguide circuitry produce a reflected wave which makes its way down the 1500-ft waveguide to the transmitter room. To protect the transmitter from this reflected wave, an antenna tuner is installed at the output of the transmitter. This “EH” tuner is a magic T hybrid, a 4-port microwave junction, as shown below in Figure 1. Motor-driven shorts are installed in Ports 3 and 4. The position of these shorts can be adjusted by operating joy stick switches at the transmitter console.

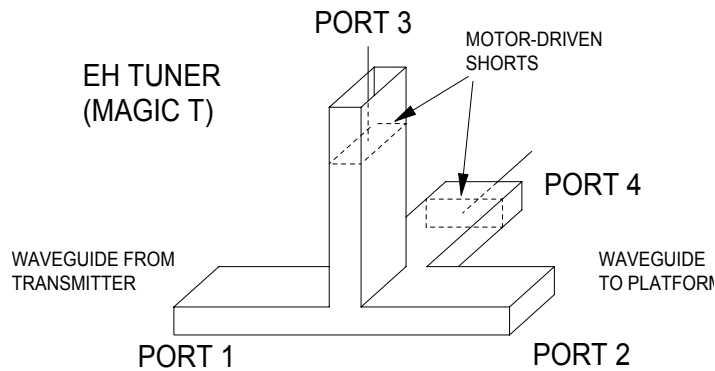

Figure 1 EH Tuner

It is interesting to see that this device is capable of presenting the transmitter with a perfectly matched load for any reflection coefficient appearing at the end of the waveguide. Figure 2 is a circuit diagram of the tuner, showing the four ports and the voltage transmission coefficients on the paths between these ports.  $\Gamma$  is the reflection coefficient at the end of the waveguide and  $\rho$  is the reflection coefficient seen by the transmitter.

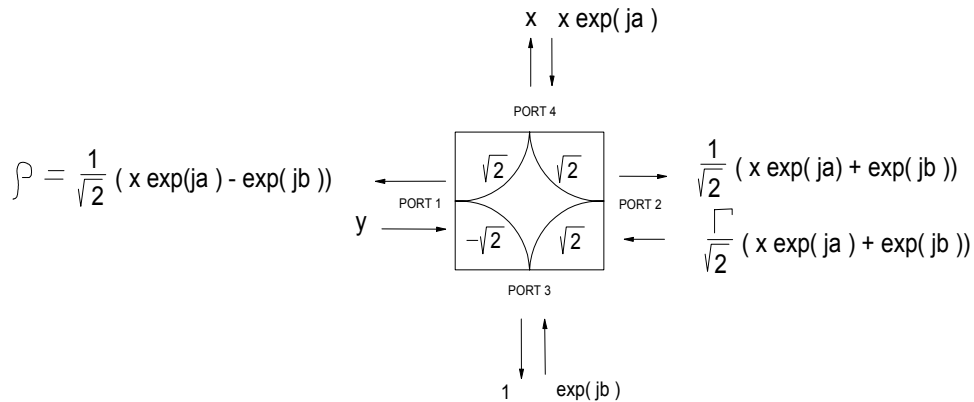

Figure 2 Circuit Diagram

The figure contains the essentials of the analysis. At each port, arrows show the direction of the incoming and outgoing waves. The amplitudes shown for these waves are derived as follows.

We can begin by assuming, arbitrarily, that the wave exiting Port 3 has an amplitude of  $1 + j0$ . This choice will determine all the amplitudes, including  $y$ , the amplitude of the incident wave from the transmitter. The short on this port causes a total reflection, so the amplitude of the wave reflected back into Port 3 can be written as  $e^{jb}$ , where  $b$  is determined by the position of the short.

The wave leaving Port 4 is still unknown. We denote its amplitude as  $x$ . Likewise, we will denote the amplitude of the incident wave from the transmitter as  $y$ . The amplitude of the wave reflected back into Port 4 is therefore  $x e^{ja}$ , where  $a$  is determined by the position of the short on Port 4.

From the figure, we see that wave leaving Port 2 is just  $2^{-1/2}$  times the sum of the waves entering Ports 3 and 4. This figure is indicated on the figure, together with  $\Gamma$  times this sum, which is the wave reflected back into Port 2.

The waves incident on Ports 3 and 4 determine the wave leaving Port 2, as shown on the figure. The wave incident on Port 2 is just the outgoing wave, multiplied by  $\Gamma$ . By inspection, we can now write expressions for the wave leaving Ports 4 and 3.

$$x = \frac{y}{\sqrt{2}} + \frac{\Gamma}{2} (x e^{ja} + e^{jb}) \quad 1)$$

$$1 + \frac{y}{\sqrt{2}} = \frac{\Gamma}{2}(xe^{ja} + e^{jb}) \quad 2)$$

Adding Equations 1 and 2,  $y$  is eliminated, leaving

$$x + 1 = \Gamma(xe^{ja} + e^{jb}) \quad 3)$$

Solving Equation 3) for  $x$ , we find

$$x = \frac{\Gamma e^{jb} + 1}{1 + \Gamma e^{ja}} \quad 4)$$

From the figure, we see that, in terms  $x$ , the wave leaving Port 1, i.e. the wave reflected back to the transmitter is given by

$$\rho = x \frac{e^{ja}}{\sqrt{2}} + \frac{e^{jb}}{\sqrt{2}} \quad 5)$$

Substituting Equation 4 to eliminate  $x$ , we find

$$\rho = \frac{e^{ja}(\Gamma e^{jb} + 1) + e^{jb}(\Gamma e^{ja} + 1)}{1 + \Gamma e^{ja}} \quad 6)$$

If the tuner is to make  $\rho = 0$ , the numerator of Equation 6 must vanish. This gives us

$$\frac{e^{ja}}{2} + \frac{e^{jb}}{2} = \Gamma \quad 7)$$

The phasors on the left-hand side of Equation 7 have magnitude  $1/2$ . The maximum magnitude of  $\Gamma$  is unity. It is easy to see that any  $\Gamma$  can be flanked by the pair of phasors in a way that satisfies Equation

7. See Figure 3, below.

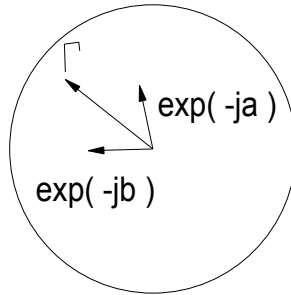

Figure 3 Canceling  $\Gamma$

Note that Equation 7 allows us to measure  $\Gamma$  by simply measuring  $a$  and  $b$ , the round-trip phase paths in the two shorting arms of the tuner. By fitting scales to the shorting arms, we could read  $a$  and  $b$ . To set the scales, we could simply disconnect the waveguide and substitute a shorting plate. Then a network analyzer would be placed at the transmitter side and the shorts adjusted to eliminate any reflection. At these positions,  $a$  and  $b$  must be  $\pi$ . The rate of change, in radians per inch, would be  $4\pi/\lambda_g$ , where  $\lambda_g$ , the guide wavelength at 430 MHz, is 36.265". (The factor of 4 rather than 2 is because the round trip distance to the short changes by two inches when the short moves one inch). Remote readouts at the transmitter console would make the calibrated tuner even more useful. After noting the values of  $a$  and  $b$ , the magnitude of  $\Gamma$  would be calculated from

**8. Dummy Load**  $|\Gamma| = \sqrt{\frac{1\% \cos(b \& a)}{2}}$  8)

The transmitter is equipped with a water-cooled dummy load. This load, on the mezzanine near the waveguide power combiner, can be rolled into place and bolted to the output of the combiner, after first removing the waveguide elbow that normally connects the combiner to the harmonic filter. The load can be used to make calorimetric measurements of the average output power, as it is equipped with a flow meter and has thermometers at its input and output. The dissipative element in the load is the water itself. The load is in series with the rest of the transmitter's water circuitry. To use the load, sodium nitrite,  $\text{NaNO}_2$ , is added to the cooling water to produce a resistivity of about 8000 ohm cm ( $125\mu\text{S}/\text{cm}$ ) at 57 deg C. This resistivity is quite temperature dependent; if the water temperature falls from 57 deg. C to 50



deg C(134F to 122F), the resistivity increases from 9000 ohm cm. It has been standard practice, over the cooling system with only distilled water (no salt), assumption that any foreign substance is undesirable As a result, the power combiner's waster load, which is dummy load, has undesirably high reflectivity. sodium nitrite is used in Navy boilers as a rust and the concentration required here is extremely low. the operations building measures about 350  $\mu$ S/cm).In poisonous, but the dilute solution should be quite nitrite is added to sausages to preserve the red color of decide to maintain the proper salt solution in the system, we should determine the corresponding value of the conductivity at room temperature, to facilitate measurement of the concentration when the system is not running.



8000 ohm cm to years, to run the under the for the system. identical to the However, preventative, (Tap water in bulk, the salt is safe.(Sodium the meat).If we

**Solution conductivity at 80 deg. F: \_\_\_\_\_  $\mu$ S/cm**

### **9. New Intermediate Power Amplifier (IPA)**

The original IPA (described in the old text, below) was replaced in March, 2004 by a pair of solid state amplifiers. Each amplifier can provide 500W at a duty factor of up to 10%. These amplifiers were made by Wavesat Inc., Model No. WPA-042044-57-47-P, as prototypes for a phased array. They were furnished to Arecibo by SRI. A controller was built for these units to provide the necessary gating (same as the the PA modulator pulse) and to allow selection of either or both amplifiers. A single amplifier is capable of producing full output when the final klystrons are tuned normally. However, if the tubes are detuned for greater bandwidth, the IPA amps can be used together, with a ring branch-line hybrid combiner. The amplifiers are flat from 420 to 440 MHz with an efficiency of about 38% Pulse rise and fall times are about 0.2usec. Gain is about 50 dB.

New IPA  
Dual 500W Solid-State Amps  
March, 2004

### *Old Intermediate Power Amplifier (IPA) (historic note)*

*This driver amplifier was the transmitter's bandwidth bottle neck (1 MHz BW). It was also the most reliable section of the transmitter, consisting of a single klystron which runs as a cw class-A amplifier. This tube was a "beam stick"; it's three cavities are external. Although the klystron had a mod anode, it was simply kept high rather than pulsed. The klystron drew about 0.5A at about 6kV, so the dissipation was a continuous 3 kW. The heat was withdrawn by a large fan in the top of the cabinet; no water cooling was used. No modifications were ever made to this IPA.*

## **10. Low-power RF and Pulse Circuitry**

This section of the transmitter has become somewhat complicated from evolutionary changes. A single TTL signal commands the modulator to turn on the beam current. The 100mW output from the exciter is gated on during the beam pulse. (Why gate the RF? The Litton klystron manual specifies that the RF pulse should "coincide with the flat portion of the dc pulse". But the RF pulse also needs to be gated so that there will be no stray 430 MHz signal present during the receiving intervals between pulses).

### **10.1 Synthesis of 430 MHz**

Two external reference frequencies, 100MHz and 10MHz are used by the transmitter. The 100 MHz signal is frequency doubled twice to produce 400 MHz. The 10MHz signal is tripled to produce 30 MHz. The 400 MHz and 30 MHz signals are then mixed to produce 430 MHz. RF gating is done both on the 400 MHz signal, just ahead of the mixer, and on the 430 MHz signal, after the mixer. The 4dBm output of the mixer is amplified to 21dBm max (100mW) to drive the solid state IPA. This circuitry resides in the "430 MHz Synthesizer / Low-Level Amplifier" chassis, except for the tripler, which is in the adjacent "Low-Level Modulator / Low Output Power Alarm" chassis. The mix of functions performed by these two chassis is as follows:

#### 430 MHz Synthesizer / Low-Level Amplifier Chassis

1. Synthesize 430 MHz from 100 MHz and 30 MHz
2. Gate the 430 MHz signal off except during the transmitter pulse

### Low-Level Modulator / Low Output Power Alarm Chassis

1. Produce 30 MHz from 10 MHz or select an external (stepped) 30 Mhz signal
2. Modulate the 30 MHz signal with a pulse, phase code, or other signal.
3. Provide an audible alarm when the transmitter output power has been off for more than 1second.

### **11. High Voltage Power Supply**

An adjustable power supply furnishes up to 4.4 amps at up to 120 kV (the rated voltage for capacitor bank). This is a negative supply, connected to the klystron cathodes. The bodies of the

klystrons are grounded. The basic power supply consists of a motor-driven variable transformer (G.E. Inductrol) operating at 4160V and feeding the high-voltage step-up transformer. The output of the step-up transformer is rectified and connected directly (no filter choke) to the 37.2 uF capacitor bank. The Inductrol is a 3-phase device (a gang of three single-phase variable transformers). There are actually two high voltage transformers. Each has its own full-wave rectifier set (six rectifiers per transformer), so the fundamental ripple component should be at 360 Hz. Measurements show that the principle ripple component is at 120 Hz.; the filter capacitors easily knock down the 360 Hz component, but are less effective at suppressing a 120 Hz component that results from slight imbalances in the transformer windings. The power supply was designed so that the rectifier sets could easily be reconnected in parallel, rather than in series, to furnish up to 75 kV at 8.8 amps. (The original Varian klystrons supported a cw mode which used reduced voltage, but the later Litton klystrons are not specified for anything but pulsed operation). The transformers have identical primary connections, but one secondary is a delta while the other is a wye. As a result, the 360 Hz ripple components are 30 degrees out of phase. Therefore, the parallel connection produced a 6-phase full wave circuit with a fundamental ripple component nominally at 720 Hz. (Nice in principle, but spoiled by the 120 Hz imbalance).



Inductrol



High voltage transformer  
(rectifiers on top)

The regulation of the power supply is specified as “approximately 12% no load to full load, excluding

the peak reading effect of extremely light loads. At 120 kV, the energy stored in the capacitor bank is 268,000 J. Even at the longest pulse length, 2.1 ms and full power, the energy extracted from the capacitor bank is only  $2.5E6 \times 1/35\% \times 2.1E-3 = 15,000$  J, or 5.6% of the stored energy. By the end of the pulse the voltage has therefore drooped by  $5.6/2 = 2.8\%$ .

This droop causes a shift in the output frequency (see Section 5). If the rectifiers ‘refresh’ the voltage during the pulse, the frequency shift will be erratic. However, if the transmitter is only pulsed between rectifier current pulses, all RF pulses will experience the same frequency shift.

### 11.1 Mod Anode Supply

The connection between the two rectifier banks provides the necessary half beam voltage needed to pulse the klystron mod anodes. This voltage can be increased by changing the tap connection on the Zener Tower. The voltage is the sum of the nominal 55kV, stored on C37, and the Zener Tower component, stored on C87.

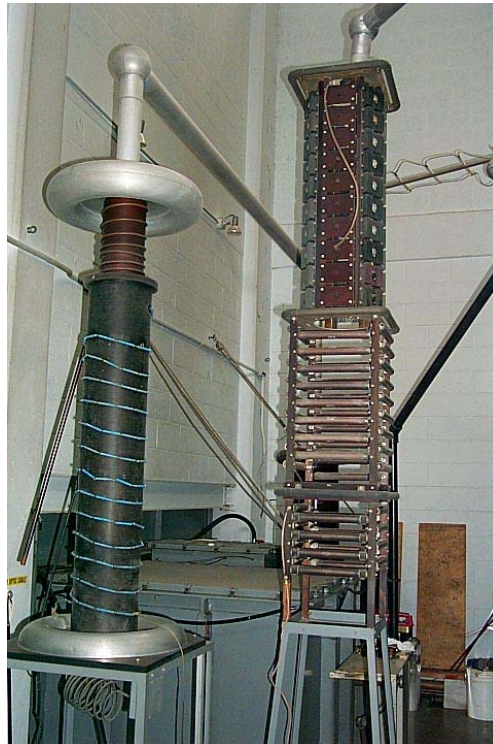

Zener tower (right) and high

voltage metering resistor (left)

## 12. Crowbar, Reflected Power Detectors and Arc Detectors

### 12.1 Crowbar

The crowbar circuit provides a fast discharge path for capacitor bank to divert the stored energy away from the klystrons. When a fault condition (normally an arc inside one of the klystrons) triggers the crowbar, charge stored in the capacitor bank is diverted to ground before the arc causes permanent damage to the klystron. (Even a limited arc can produce a sharp metal whisker in a klystron, but a whisker can be eroded away by gradual application of high voltage - "high potting" the klystron.)

The crowbar discharge takes place between two eleven-inch diameter stainless steel spheres. The voltage across the ionized gap is about 20V, independent of current. Thus the energy stored in the capacitor bank (up to 200,000 J) is almost entirely dissipated in the 4 Ohms of resistance in series with the capacitor bank. (This resistance is distributed in the form of 1000 Ohm resistor in series with each of the 248 capacitors:  $1000/248 = 4.03$  .

The arc is ignited by a pointed metal probe, whose tip is midway between the spheres. Normally the probe is held at a potential halfway between the voltages on the spheres. To fire the crowbar, a pulse transformer briefly raises the probe voltage by more than 100kV. An arc is produced between the probe and the top ball (which is at the negative B- bus potential). The probe is now forced to the B- potential, so an arc jumps to the other ball, which is connected to the B+ bus (essentially ground). There is now a conducting path between the balls to discharge the capacitor bank.

Only two fault conditions trigger the crowbar. The first is an abnormally long beam current pulse - a rare event that could be caused by a failure in the low-level pulse control circuitry or by the modulator failing to turn the beam off. The other, and much more frequent fault that triggers the crowbar is a sudden increase in klystron body current - i.e. the beginning of an arc within one of the klystrons (or from the B-supply bus to ground). The long-pulse detector, an analog RC integrator, is on Chassis A. The body current spike detector, a differentiator, is on Chassis B, together with the 5C22 hydrogen thyatron that discharges C803B through the primary of a pulse transformer



Crowbar discharge balls. Capacitors at left are part of the capacitor bank.

to produce a high voltage pulse at the secondary which ionizes the air between the metal spheres of the crowbar. Each capacitor in the capacitor bank has a 1k series resistor. These resistors limit the discharge current to safe values that will not blow up the crowbar or burst the capacitors.

( $100\text{kV}/1000 = 100$  amps per capacitor;  $100 \text{ amps} \times 248 \text{ capacitors} = 24,800$  amps total initial discharge current). Assuming voltage across the ionized crowbar gap is a constant 20V, the energy dissipated in the arc is only 80J out of the 200kJ dumped from the capacitor bank.

The 75-Ohm resistor, R25, in series with the klystron collectors, limits any klystron arc current, extinguishing the klystron arc as the crowbar lowers the voltage. Before the crowbar fires, the arc discharge current in the klystron is limited to  $100,000/75 = 1333$  amps. This 75-Ohm nichrome resistor is also inductive, so an arc probably will not reach the maximum current before the crowbar fires. Destruction of the 75-Ohm resistor (fuse action) results if the crowbar fails to fire.

It would be worthwhile to add indicator circuitry to the crowbar chassis that would latch the triggering event to tell whether a given crowbar firing was due to excessive pulse length, a body current spike (including current any spikes from anywhere on the the B- bus to ground), or just a spontaneous firing of the thyatron.

Two push buttons are provided for test firing the crowbar. One is located in side the right side cabinet door of the console. The other is located on the crowbar chassis.

## 12.2 Reflected Power and Arc Alarm/Shut-off Chassis

Since the klystrons can be damaged if they are connected to a reflective load, each klystron is equipped with a reflected power detector, a diode detector connected to a 50 dB coupler at the klystron output. Between the diode detector and the coupler there is a 2 dB pad, a filter, and additional attenuation due to the long coax lines between the couplers (on the mezzanine) and the diodes (inside the console). With a forward power of 1Mw, a reflection of -20dB produces a detected voltage of about 1.5V.

The detected voltages, one for each klystron, are connected to adjustable threshold detectors. This circuitry is in the console, in the Reflected Power and Arc Alarm/Shut-off Unit. Refer to the schematic diagram , dwg. 430\_124, "Reflected Power and Arc Alarm/Shut-Off Unit.

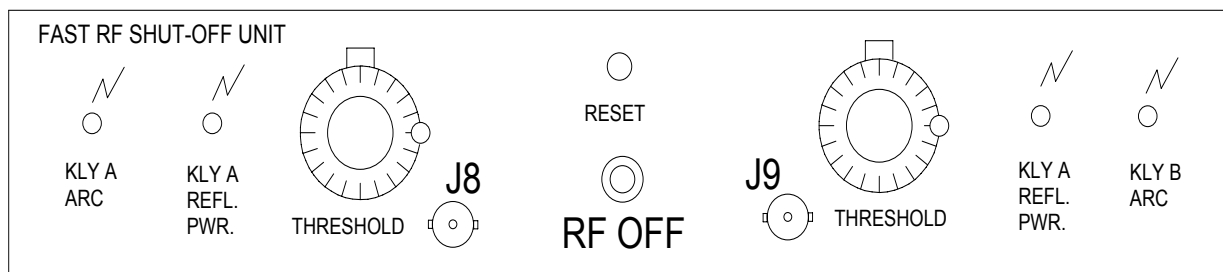

Excessive reflected power trips this unit, turning on the red KLY A REFL PWR or KLY B REFL PWR lights, and gating off the Synthesizer / Low-Level Amplifier Chassis. (See dwg. 430\_119, “Pulse Control Block Diagram”). While adjusting the EH tuner to minimize the reflected power, the threshold knobs can be turned fully counterclockwise to make the threshold high. If necessary, press “Reset” to turn off the red lights. Once the reflected power has been minimized, the thresholds can be adjusted to the proper protection level as follows: connect the console oscilloscope to one of the “Monitor” ports and adjust the threshold so that the observed voltage is always negative. If the reflected power increases enough to make the pulse rise above zero volts, the alarm will trip. Use the same procedure to adjust the reflected power threshold for the other klystron.

Whenever the unit is has been tripped, it must be reset (using the front panel “RESET” button) to re-enable the transmitter’s RF drive. A front panel “RF OFF” button provides the operator with a fast way to kill the RFdrive. When there is no RF power, the unit can be tested by turning the threshold knobs to “1” or below. The reflected power indicator LEDs should light.

### **12.2.1 Arc Detectors**

Each klystron is equipped with three photo-diodes at the coax-to-waveguide transitions. Signals from the three diodes are combined in a wired OR connection. Latched detectors - one for each klystron, are connected to the photo-diode triplets. When a detector is tripped, it opens a relay contact connected to the high voltage interlock chain and also sends a -30 volt pulse (30V to 0V) to the Reflected Power and Arc Alarm/Shut-off Unit. As after any event that breaks the interlock chain, the fault must be cleared before the high voltage can be again brought up. In this case, the console “PA Reset” button unlatches the relay in the arc detector, completing the interlock chain. RF drive must also be reset, by pressing the “Reset” button on the Reflected Power and Arc Alarm/Shut-off Unit.

The original manual states: The response time of the arc detector to a five joule arc at a distance of a foot is about 1 microsecond.” The Arc Detectors are shown in the schematic “Arc Detectors 430 MHz Transmitter”.

## **13. Modulator**

As explained earlier, the function of the modulator is to turn off the klystron beam current when it is not needed, i.e. when the RF drive pulse is off. Pulsing the beam on only when needed lowers the average input power by a factor of  $1/.06 = 16.7$  at the maximum duty factor of 6% and even more when the duty factor is smaller. Cutting off the beam current also eliminates noise that is generated by the beam even in the absence of RF drive. The klystrons contain a control element, the



“mod anode”, which can be biased to turn the beam current off or on. The mod anode is a capacitive load (75 pF/klystron); it draws no current, except while charging or discharging.

To understand the operation of the modulator, refer to Drawing 430\_116, "Simplified Modulator Schematic". The modulator is based on two high-power switch tubes. The upper switch tube, V301, turns the beam on by connecting the mod anodes to a -55kV tap on the power supply, a

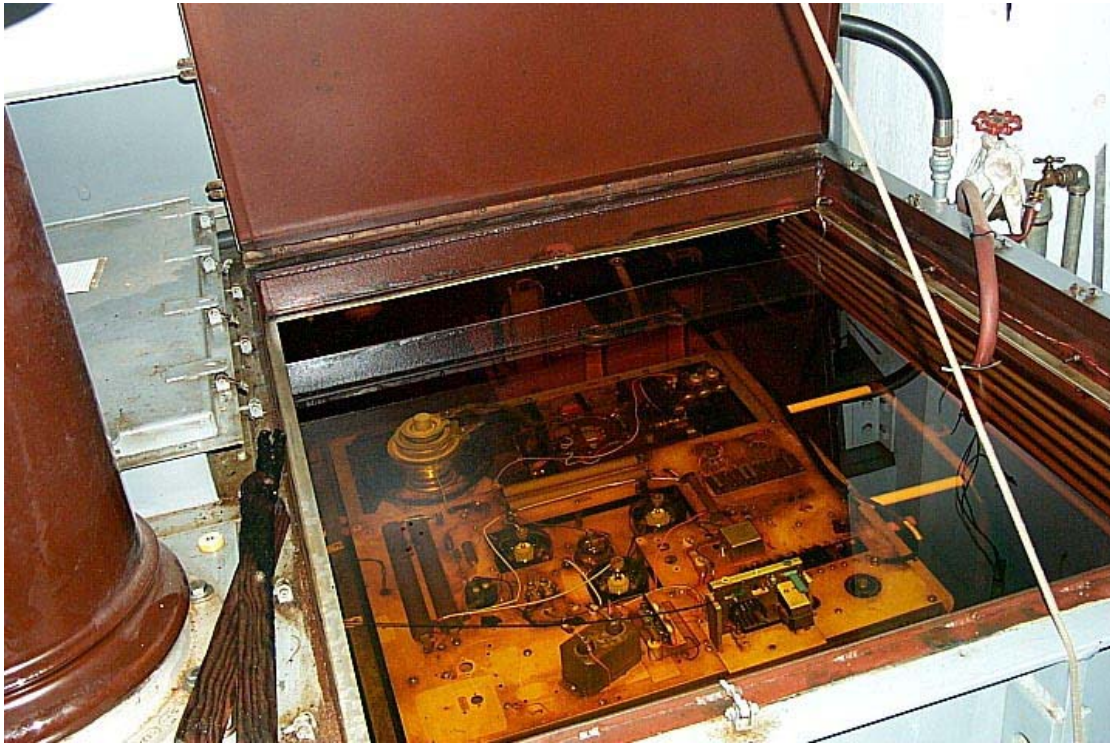

Floating deck chassis in oil tank. The hatch door is open. The buffer deck is in the left side of the tank, to the left of the oil-filled high voltage bushing.

voltage midway between cathode and anode potential. (This voltage is adjustable; see Section 13.3). The lower switch tube, V401 (the “tail clipper”), turns the beam off by connecting the mod anodes to a supply voltage of -115kV, 5kV lower than the power supply B- voltage. As in any totem pole circuit, it is important that both tubes must never be simultaneously turned on (“shoot through”). These tubes, Machlet type ML8038, can handle currents up to 175A and standoff voltages up to 125kV. Each switch tube dissipates 2665W in filament power (13.0V @ 205A). Since the upper tube must pull the mod anodes up from -115kV to -55kV, its cathode, rather than its plate, must be connected to the mod anodes. And since the tube's drive voltage (grid voltage) is referenced to its cathode, the chassis of its drive circuit must be tied to its cathode and hence to the mod anodes. Because this entire chassis is pulled up and down between -55kV and -115kV, it is known as the "floating deck". The two mod anodes in parallel are equivalent to a capacitor of  $2 \times 75\text{pF} = 150\text{pF}$ .

The modulator's job is to charge and discharge this capacitance. But the parasitic capacitance of the floating deck itself to ground is about 900pF. The modulator does much more work charging and discharging its own chassis, the floating deck, than the useful work it does in charging and discharging the klystron mod anodes! The charge and discharge currents are large; to charge 1050pF to 55kV in 1 microsecond, the average current during the microsecond will be  $CV/10^{-6} = 58$  Amperes.

### 13.1 Modulator Circuit Description (Floating deck charges mod anode up; buffer deck discharges it).

Referring to the Simplified Modulator Schematic, Dwg. 430\_116, the floating deck is at the top of the page. The cathode (filament) of the switch tube, V301, is tied (through a 9-ohm resistor) to the chassis of the floating deck and this chassis is tied to the klystron mod anodes. When the grid of the switch tube is made positive with respect to its cathode the tube conducts and pulls the floating deck up to its plate potential, the -55kV tap from the beam supply. The positive grid drive comes from a 2200V power supply on the floating deck. This grid drive voltage is applied by a cathode follower circuit made of two 4\_400A tubes in parallel (V303 and V304). The presence of light in the optical command fiber causes the grid voltage of V302 to fall. This tube turns off and its plate voltage rises from 500V to 1000V. The cathode follower delivers this plate voltage to the grid of V301, the switch tube, turning it on. A floating bias supply in series with the switch tube grid maintains the grid at about -1000V between pulses to keep it cut off. The operation of the clamp tube, V307 is explained later. Note that if V302 has low emission, the deck will remain on, causing 'shoot-through', i.e. both decks conducting at the same time.

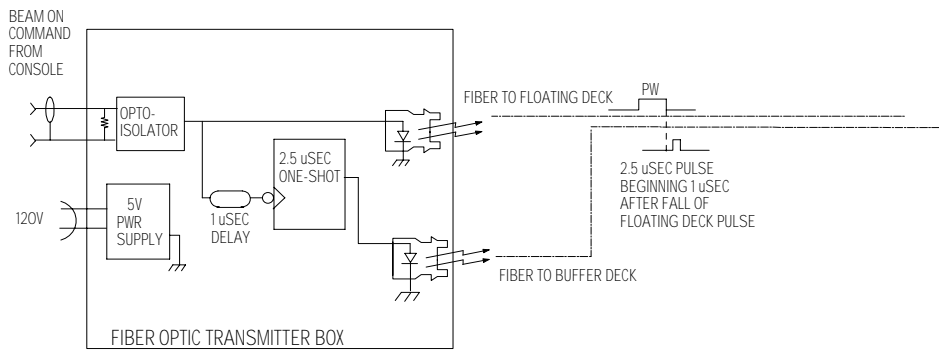
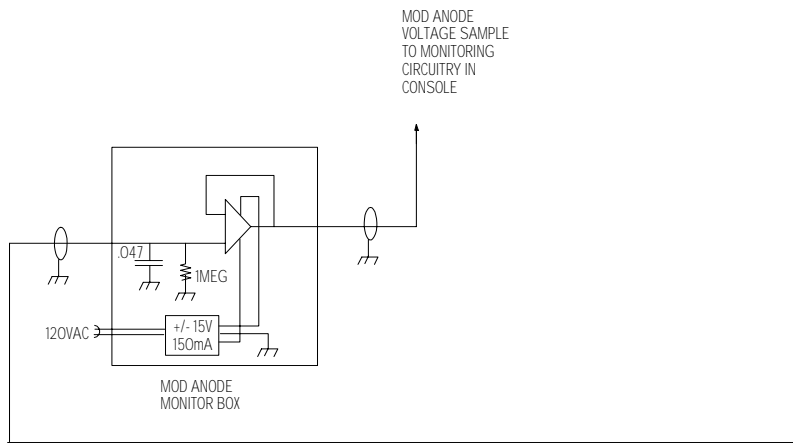

SIMPLIFIED MODULATOR SCHEMATIC: page 1 of 3

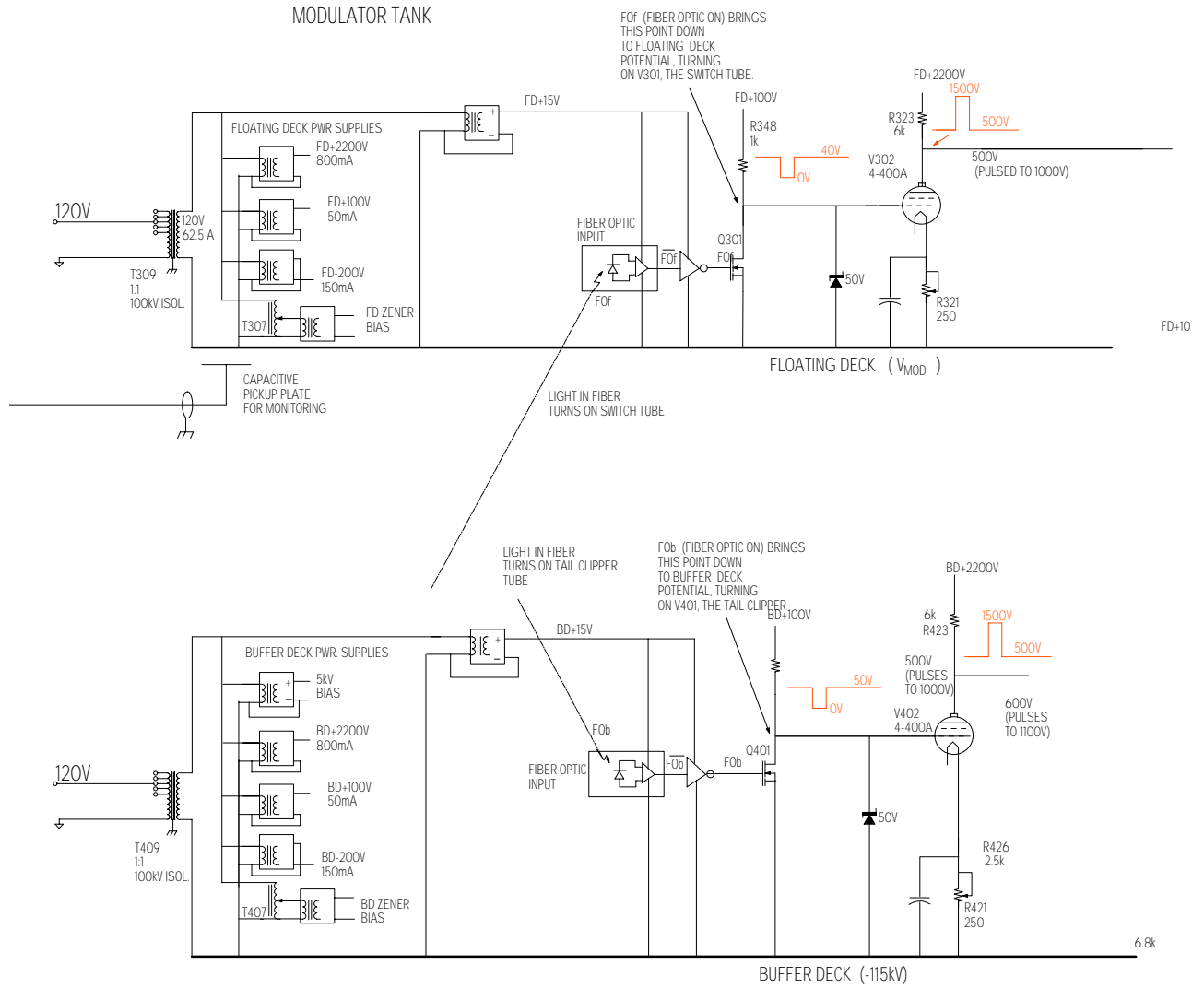

SIMPLIFIED MODULATOR SCHEMATIC: page 2 of 3

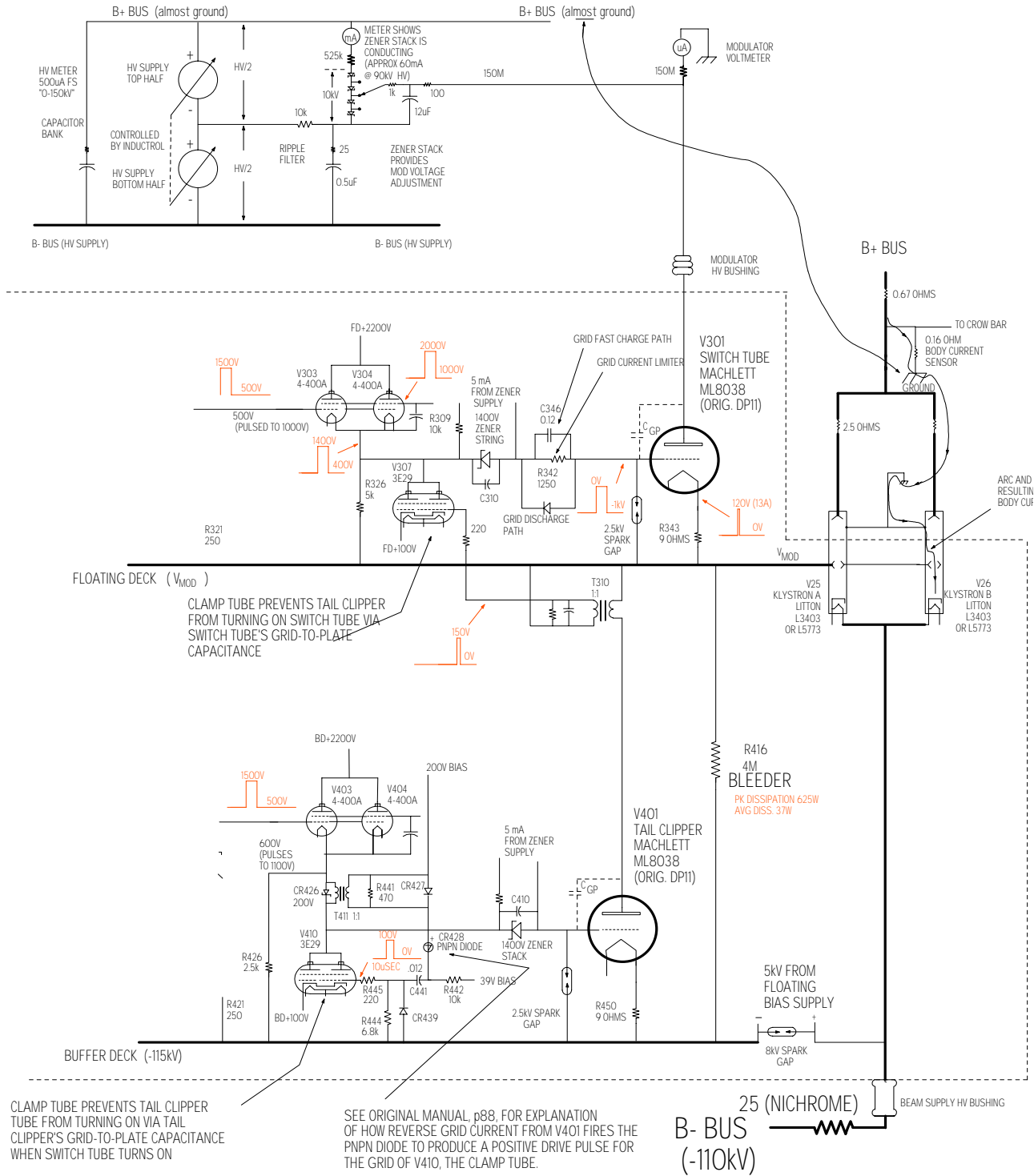

SIMPLIFIED MODULATOR SCHEMATIC: page3 of 3

The buffer deck is at the bottom of the simplified modulator schematic. Its switch tube, V401, pulls the mod anodes (and the floating deck) down to the potential of the buffer deck chassis (5000 volts lower than the beam supply B- voltage). This switch tube is known as the "tail clipper" because it is used only to produce a momentary pull down to discharge the capacitance of the mod anodes and the capacitance of the floating deck chassis. This discharge leaves mod anode (and floating deck) 5000 volts more negative than the klystron cathode, completely turning off the klystron beam current. Once the tail is clipped, the floating deck is then maintained low by the 4 Megohm hold-down resistor, R416, between the floating deck and the buffer deck. The drive circuitry for V401, the tail clipper, is almost identical to the drive circuitry in the floating deck, comprising a cathode follower (V404 and V403 in parallel) and a voltage amplifier (V402) to increase the signal from the fiber optic receiver. The buffer deck is turned on just after the floating deck is turned off and is kept on for a fixed 2.5 microseconds, which is enough to discharge the mod anodes and the floating deck. Note that if V402 has low emission, the buffer deck will stay on, causing "shoot-through", i.e. both decks conducting at the same time.

Each deck has a 3E29 as "clamp tube" to discharge its switch tube grid. To see why this is necessary, consider first V301, the floating deck switch tube. At the end of a pulse, the switch tube has been turned off by driving the grid negative. One microsecond later, the buffer deck tube, V401, starts its 2.5 microsecond pulse, pulling the floating deck down in voltage. As the floating deck is pulled down, the grid-to-plate voltage of V301 rises, so current must flow out of the grid. If there is not a low impedance path for this current, the grid to cathode potential will rise, trying to turn on V301 at the same time as V401: the dreaded "shoot-through" situation. The discharge path for the grid current is the 5k resistor, R326. Since the cathode follower is in parallel with this resistor, the combination is a low impedance path - until the grid current exceeds the bias current in the resistor. At that point, the cathode follower tubes turn off and the discharge path is the high impedance 5k resistor. It is necessary to provide a low impedance path that will stay active during the entire discharge. The clamp tube, V307, does this job. This tube is turned on automatically as current in the tail clipper tube, V401, flows through the primary of the transformer T310. The secondary winding applies a positive pulse to the grid of the clamp tube, activating the clamp turned on while the floating deck discharges.

The buffer deck clamp is similar. The pull-up of the floating deck tries to lift the grid voltage of V401, which would turn on V401 together with V301 (shoot-through). The scheme used to turn on the buffer deck clamp is more circuitous than the simple transformer used to turn on the floating deck clamp. As the floating deck begins to rise in potential, grid current wants to flow out of the grid of

V401, through to the plate-to-grid capacitance of that tube. This initial current flows through the primary of a one-to-one isolation transformer, T411. The voltage induced in the secondary triggers a one-shot, which supplies a 200volt, 20usec pulse to turn on the clamp tube. The clamp tube cathode is biased at +100V, so its grid bias rises to 100V and is held there by the grid-cathode diode action on the positive grid current (which is limited by R445). Note that the buffer deck clamp tube is not activated by the normal turn-on of the buffer deck because the charging current for the grid of V401 flows backward through the Zener diode CR426 which, acting as an ordinary diode, shorts the primary of T411. (Even without this diode action, the pulse produced at the transformer secondary would have the wrong polarity to trigger the one-shot. And, in any event, CR427 snubs the negative pulse).

### 13.2 Modulator Control

Both the floating deck and the buffer deck are controlled with optical fibers. These fibers provide isolation from chassis that are as much as 120 kV away from ground potential. The floating deck fiber is turned on and kept on during the time the klystron beam is to be on. The buffer deck fiber is turned on 1 usec after the floating deck fiber is turned off and is then turned off after a fixed 2 microsecond delay. Two microseconds is sufficient time for the buffer deck to discharge the combined capacitance of the mod anodes and the floating deck. We are presently installing an additional fiber to each deck. These fibers will activate the clamp tubes by external command, which will make it easier to test and trouble-shoot the decks individually. But the clamp tube turn-on circuits described above will be retained, “ORed” with the external commands, as backup protection.

### 13.3 Modulator Supply Voltage

The figure below shows how the modulator supply voltage is derived from the half-voltage point of the beam supply. This tap on the beam supply has ripple, which is filtered by R86 and C36. Adjustability is provided through a stack of 50 Zener diodes, each of 50 volts. The voltages indicated in the figure correspond to the operating condition for the never L5773 klystrons: 95kV beam supply, 48.5kV mod anode amplitude.

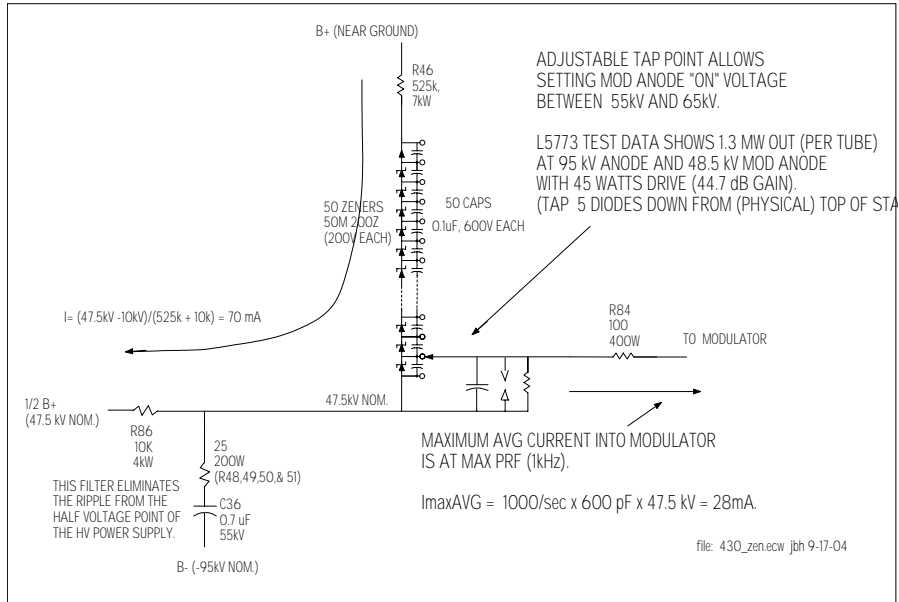

Oil purifier/filter in shelter next to one of the two stainless steel oil storage tanks.

### 13.4 Modulator Oil



A 2000 gallon tank of mineral oil (Texaco transformer oil, codigo 1515) provides high voltage insulation and convection cooling for the modulator. The buffer deck and floating deck are both submerged in this oil. Two 2500 gallon stainless steel tanks provide temporary storage space for the oil, which is pumped out of the modulator tank when the modulator circuitry is repaired or modified. The oil filtering and storage system is shown in the figures on the following pages.

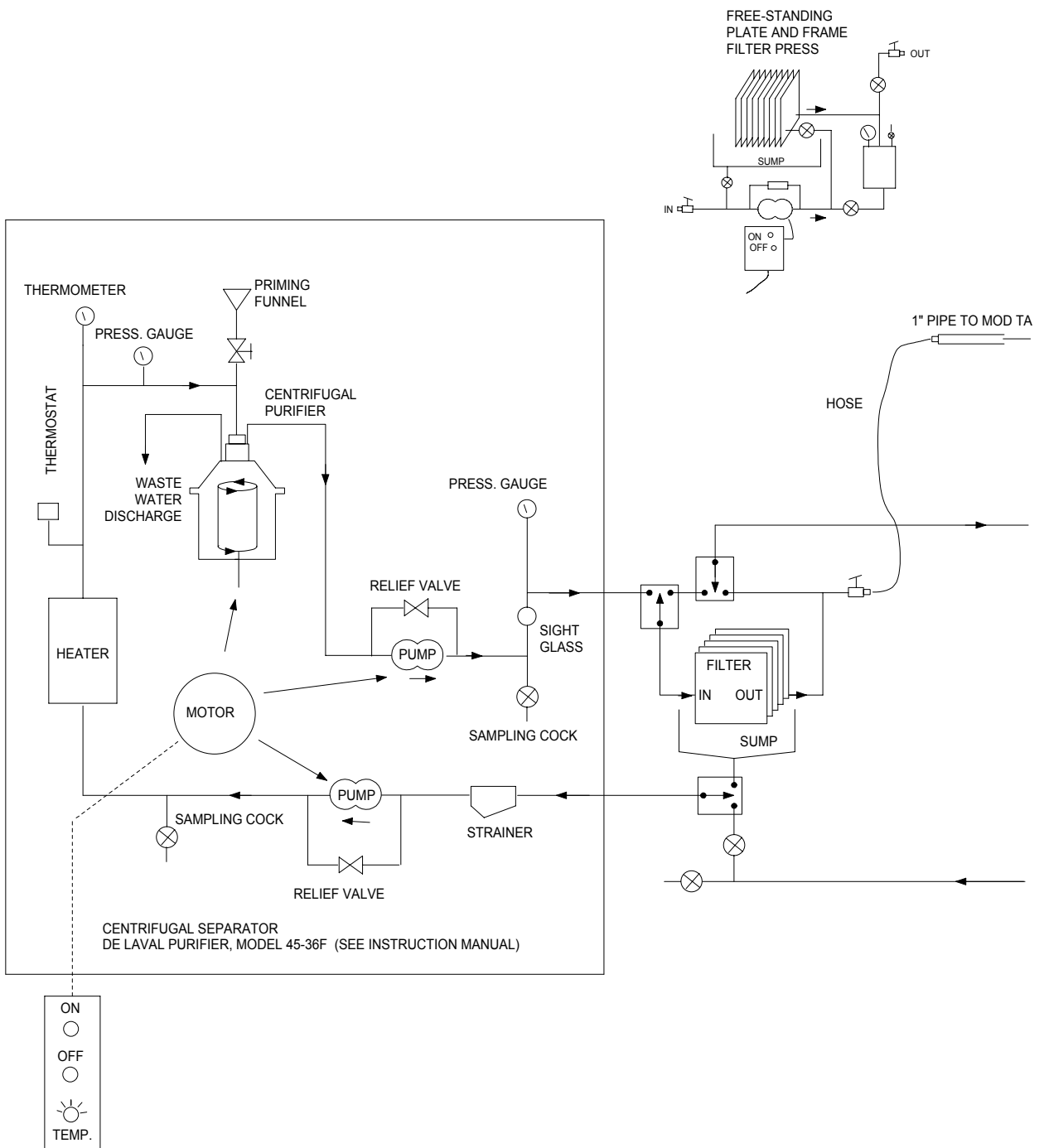

OIL FILTERING & STORAGE p. 1 of 2

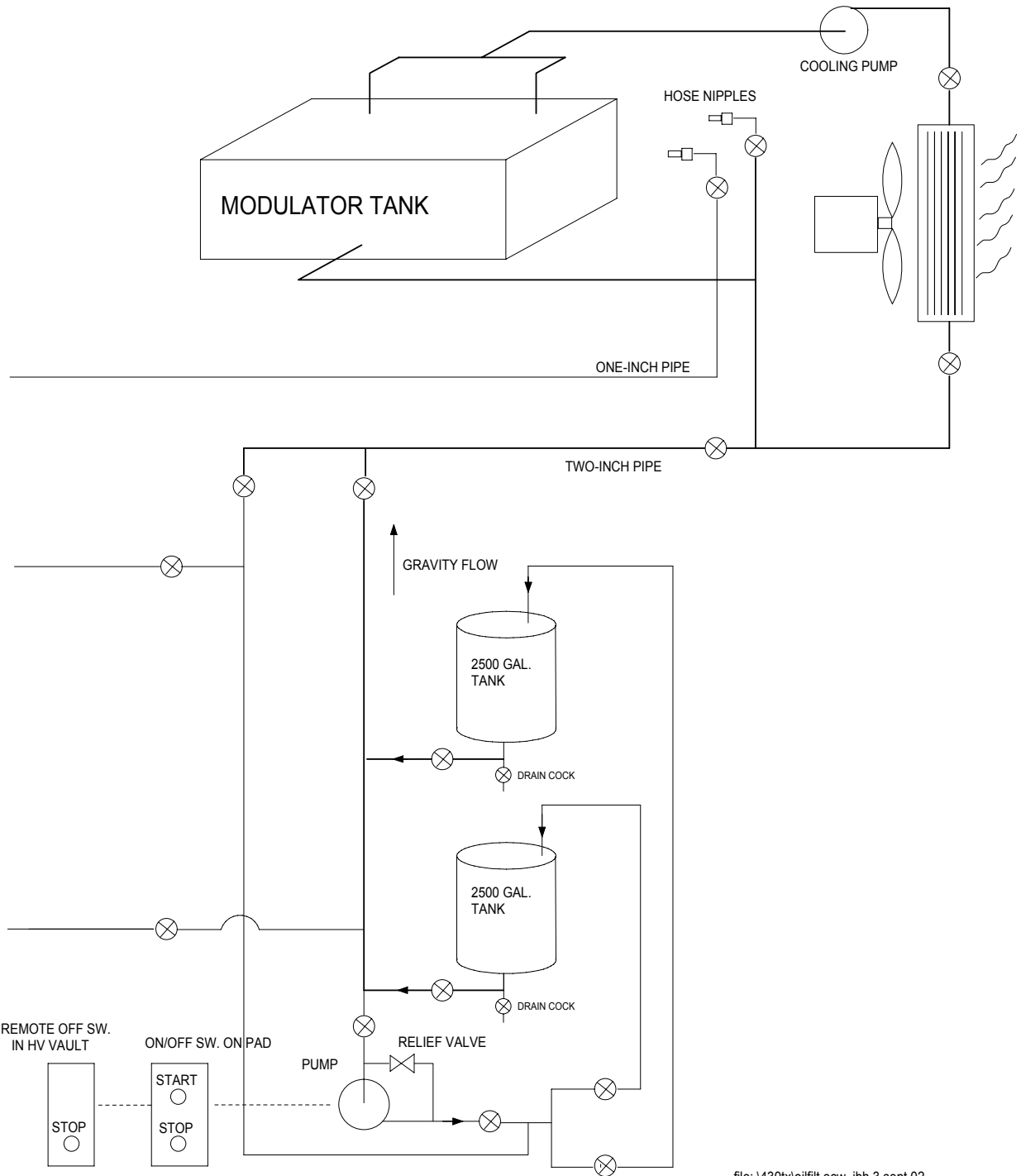

file: l430txloifilt.ecw jbh 3 sept 02

OIL FILTERING & STORAGE p.2 of 2

#### **14. Cooling System (see section 3.3)**

#### **15. Monitoring System**

Refer to the monitor system schematic, Dwg. No. 430\_107, which replaces the original drawing, J349C107. The ac and dc power metering is straight forward. The meters themselves are on the front panels in the control console or inside the console, behind the door on the right-hand side. Most of the metering circuitry is obvious. Less obvious metering is discussed below.

##### **15.1 AC line voltage monitor**

Three digital voltmeters are connected to the three phases of the transmitter's input power line, following a transformer step-down from 4160 volts. The transformer secondary has a wye connection, so each meter measures the voltage from one leg of the wye to the grounded center connection. The nominal reading for each phase is 120 V. A selector switch allows the meters to read "Commercial" or "Generator": the former means the meters are connected as described above to the input power line of the transmitter. The latter, "Generator", means that the meters are connected to the normal house power rather than the lines dedicated to the transmitter. When commercial power fails, the observatory generator does not supply power to the transmitter power lines, but does supply house power, hence "generator". This metering feature, not needed for transmitter operation, was supplied simply because there was not another set of meters in the control room to read the line voltage during emergency generator operation.

##### **15.2 Klystron solenoid magnet currents**

Each klystron has eight solenoid magnets to prevent divergence of the beam. A meter is provided for every magnet (16 meters). The original meters were meter relays with an adjustable auxiliary contact that would close if the current falls below the selected value. The opening of any one or more of the 16 contacts would operate a relay to open the interlock chain. The original meters, no longer available, are being replaced with ordinary meters, fitted with circuitry to provide the auxiliary contact feature.

This circuitry is on the last page of the metering system schematic, Dwg. No. 430\_107. A small push button below each meter lets the operator view the set point, which can be adjusted by a trim pot, accessible through a hole next to the push button. A red magic marker can be used on the glass to indicate the position of the set point. The meter circuitry includes a pulse stretcher; if there is a momentary interruption of the current (e.g. from a loose contact or connector), the meter will drop to a low value for about 1 second - long enough to be noticed by a sharp-eyed troubleshooter. (NOTE: AS OF 6-05, THESE 'METER RELAY' CIRCUITS HAVE STILL NOT BEEN INSTALLED).

### 15.3 Klystron filament power meters

Each klystron has a dynamic watt meter to monitor its filament power. These readings should thus be true power indicators, independent of the ac waveform.

### 15.4 Forward and reverse RF power metering

The transmitter is fitted with many directional couplers. Most are in waveguide. At least one is in coax, in the line between the IPA and the PA. Most of these directional couplers are fitted with diode detectors, and supply their respective meters or threshold detector circuits with dc voltages that represent average power. However six couplers bring their RF samples via coax cables to bulkhead connectors on the front of the console, where they can be connected to the built-in HP power meter or examined directly with a high speed oscilloscope. These six are total output power, waster load power, and forward and reverse powers at the outputs of each klystron. All six are derived from nominal 50 dB directional couplers. But to the 50 dB must be added the cable attenuation and the value of any attenuators inserted in the lines. The lines, RG9 coax, will contribute about 4 dB of loss (4.6 dB/100ft).

**Total forward power port:** This port contains a 15 dB attenuator, AT709. Thus its total coupling factor is around -69 dB, i.e. 50dB + 4dB + 15dB. 150kW would produce  $10 \log 150 + 60 - 50 - 15 - 4$  dBm = 12.8 dBm (19 mW).

**Total reflected power port:** This port circuit contains a 5 dB attenuator, AT708, so 15kW would produce a reading 12.8 dBm (19 mW).

**Klystron A and Klystron B forward power ports:** These ports contain 12 dB attenuators, AT704 and AT706, so 75 kW would produce 12.8 dBm (19mW).

**Klystron A and Klystron B reflected power ports:** These ports contain 2 dB attenuators, so 7.5 kW would produce 12.8 dBm (19 mW).

Obviously the designers arranged things so that when the HP power meter head is moved from one sample port to another, the expected readings will be about the same. The calibration of all these ports should be verified and recorded.

All the other directional couplers are connected directly to diode detectors. These ports should likewise be tested. It would be good to test first the diode detector/meter circuitry alone.

List of meters:

Meter	Function	Type	Location	Schem. ref.
M2	AC line voltage	0-150VAC		
M3	Kly A filament watts	0-1500W/relay	console	107,106
M4	Kly B filament watts	0-1500W/relay	console	107,106
M5	Kly A filament running time			
M6	Kly B filament running time			
<del>M7</del>	<del>Rectifier filament</del>			
<del>M8</del>	<del>Rectifier filament</del>			
<del>M9</del>	<del>Rectifier filament</del>			
M10	beam current	0-10A/relay	console	107,106
M11	body current	0-500mA/relay	console	107,106
M12	kly A coll. current	0-5A/relay	console	107,106
M13	kly B coll. current	0-5A/relay	console	107,106
M14	beam voltage	0-150kV/relay console		107,106
M15	Kly B vac-ion pressure			
M16	Kly B vac-ion pressure			
M17	cap. bank short detect.	50ma w/relay	Cap. bank	430_106, 430_107
M18	4160 VAC phase detect	0-150VAC/relay		430_106,430_107
M19	4160 VAC phase detect	0-150VAC		430_106,430_107
M20	208 VAC phase detect	0-150VAC		430_106,430_107
M21	208 VAC phase detect	0-150VAC		430_106,430_107
M22	mod. supply voltmeter		Console	430_107, 430_107

M101-24 IPA beam current

M102-24 IPA body current

M103-24 IPA collector volts

M104-24 IPA beam voltage

M201-24	IPA Pre-focus magnet current	Console
M202-24	IPA 1 <sup>st</sup> body magnet current	Console
M203-24	IPA 2 <sup>nd</sup> body magnet current	Console
M204-24	IPA 3 <sup>rd</sup> collector magnet current	Console

M601	kly A, magnet #1	0-10A/relay	Console	107
M602	kly A, magnet #2	0-10A/relay	Console	107
M603	kly A, magnet #1	0-10A/relay	Console	107
M604	kly A, magnet #1	0-10A/relay	Console	107
M605	kly A, magnet #1	0-10A/relay	Console	107
M606	kly A, magnet #1	0-10A/relay	Console	107
M607	kly A, magnet #1	0-10A/relay	Console	107
M608	kly A, magnet #1	0-10A/relay	Console	107
M609	kly B, magnet #1	0-10A/relay	Console	107
M610	kly B, magnet #2	0-10A/relay	Console	107
M611	kly B, magnet #3	0-10A/relay	Console	107
M612	kly B, magnet #4	0-10A/relay	Console	107
M613	kly B, magnet #5	0-10A/relay	Console	107
M614	kly B, magnet #6	0-10A/relay	Console	107
M615	kly B, magnet #7	0-10A/relay	Console	107
M616	kly B, magnet #8	0-10A/relay	Console	107

M701 dummy load power

M702 waster load power

M703 Kly A&B Output power

M704 Kly A&B Input power

M705 IPA input power

M706 IPA Output power Console 107

M707 HP power meter Console

## 16. AC Power Control Circuitry

A detailed description of the power and control circuitry begins on page 10 of the original manual. Refer to Drawing 430\_106, "AC power distribution overall". The transmitter is almost entirely powered by the 4160 volt 3-phase service that enters the main disconnect switch in the transmitter room on the wall of the high voltage vault (see figure below). This switch is normally on; it is turned off only for maintenance work.

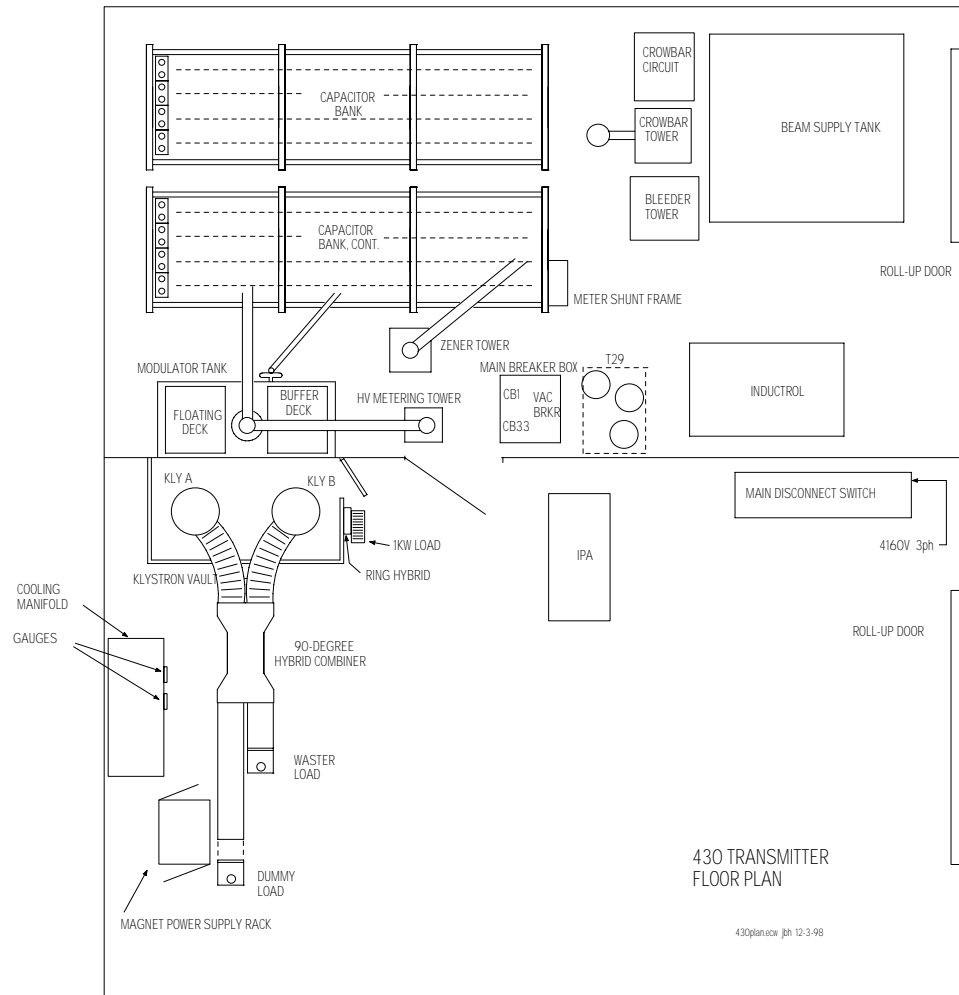

### Transmitter Room Layout

Power from the disconnect switch is routed to three single-phase transformers, where it is stepped down into three independent 120 V single-phase lines, “phA, phB, and phC”. These lines power most of the auxiliary equipment such as pumps, fans, control relays, and low-power control and exciter chassis. Power from the disconnect switch is also routed to the large oil circuit breaker in the switchgear rack, just inside the high voltage vault, to the right of the doorway as one enters. The oil circuit breaker supplies power only to the high voltage power supply. Following the oil circuit breaker is a faster disconnect system, the Jennings vacuum contactors, K001A, K002A, and K003A. This fast disconnect can be triggered by over current sensed in either of two phases (sensed by K66 and K65) or by the operator pressing PA HV OFF at the console, or by any of the many fault conditions that open the interlock chain.

### 16.1 Turn-on sequencing



A series of time delay relays and electro mechanical timers energize the transmitter circuits as follows:

Operator pushes the button *PA System On* . Relay K4 closes and one of its contact pairs turns on K6 and K8, which turn on the heat exchanger fans. The other contact pair on K4 shorts the push button, latching K4, which turns on the green lamp and applies power to K9, a 5-second time delay relay.

**5 seconds later**, K9 applies power to K7 and K13, which turn on the main pump and the booster pump and energizes K10, a 2-second time delay relay.

**2 seconds later**, K10 turns on K14, which once turned on the HV rectifier filaments, and K11, a 7-second time delay relay.

**7 seconds later**, K11 turns on K15, which energizes the magnets and energizes K12, a 2-second time delay relay.

**2 seconds later**, K12 turns on K20, which supplies power to the klystron filaments and energizes K24 and K25 which are 15 minute timers, to allow the filaments to warm up.

**15 minutes later**, the contacts of K24 and K25 to complete the interlock chain, turning on the orange lamp *PA HV READY*.

The operator can now push the button *PA HV On*. This will turn on and latch the red lamp *PA HV On* and close and latch the vacuum contactors in the 4160V 3-phase lines to the Inductrol. Assuming the IPA has been turned on, the operator can now raise the IPA's high voltage and then the PA's high voltage.

## **16.2 Power Tripping and Resetting**

About one hundred different conditions break the interlock chain (see dwg 430\_106, p5) and thereby trip the *PA HV ON* circuit (see dwg 430\_106, p2). Once the fault has been corrected, restoring continuity to the interlock chain, the operator can again turn on the high voltage. (Some fault situations require the operator to first press the *RESET* button).

## 17. Timing system

### 430 TX Timing Generator (mounted in the transmitter console)

#### 17.1.0 Introduction

This console-mounted unit (Figure 1) imposes protective limits or extensions, when needed, on the four external timing *request* signals, converting them into four equivalent timing *command* signals for the 430 MHz radar system. These limits or extensions are applied *a.* when the externally supplied requests violate specified limits and *b.* in the event of ac power dips. In addition to this protective circuitry, the unit includes an internal timing generator for stand-alone transmitter testing.

#### 17.2.0 Control Signal Requests

Four externally supplied TTL lines are used to control the radar timing. These lines (including their traditional names) are listed below in the usual order of activation.

##### **1. Receiver Protection Request (IPP)**

This pulse turns on the receiver protectors (monoplexers). Normally the computer raises this line about 5 microseconds prior to starting the RF pulse, to be sure that the receiver is fully protected before any RF (leakage) arrives. Protection Request should be maintained high throughout the RF pulse and lowered a few microseconds *after* the pulse to avoid hitting the receiver with echoes from close-in clutter and transmission line reflections. (If only a brief request is sent, followed in less than 25 microseconds by an RF Request, (as with the previous timing system) the unit will produce a protection command that stays high until 20 microseconds after the RF Request goes down).

##### **2. Beam Request (Pulse)**

The klystrons can produce power only when their beams are on. It is good practice to keep the beams off until the receiver protection is active, as the klystrons can emit a burst of noise when the beam turns on, even while the RF drive is still absent. When only the beams are on, the klystrons produce enough noise power to render the receiver useless and, in the event of a crowbar, the klystrons may produce a potentially damaging noise pulse). Thus Beam Request should be raised *no sooner than 2 usec after* Protection Request is raised and lowered *before* Protection Request is lowered.

##### **3. RF Request (RF Gate)**

This pulse applies RF drive to the klystrons. The RF Request should not be raised until the beam current is fully on, as specified by the klystron manufacturer. Note that RF Request can also be turned off and back on during the beam pulse, in order to transmit a burst of two or more shortpulses.

##### **4. Phase Request (Phase)**

This signal flips the phase of the transmitted signal by 180 degrees and is used to apply phase coding to the transmitted signal.

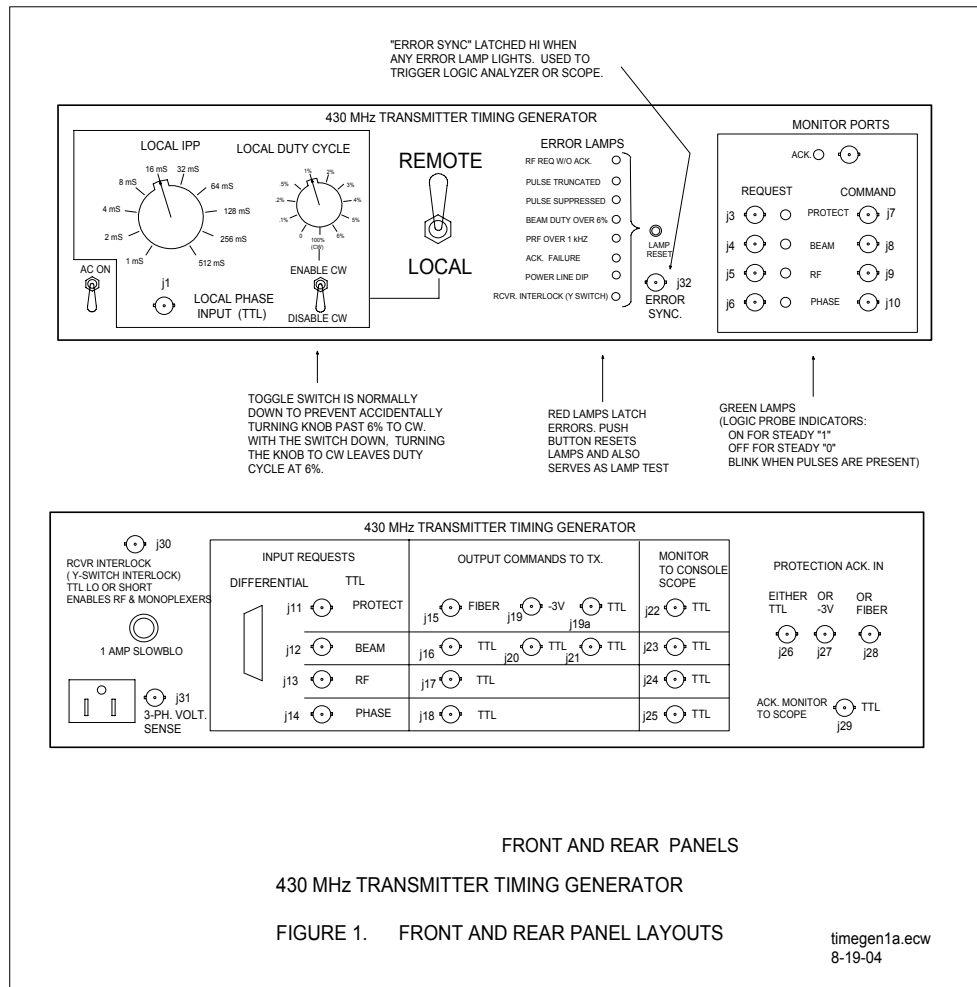

### 17.3.0 Signal

**Control Comma**

The request signals are converted into the command signals as follows:

1. *Receiver Protection Command* (sent to the platform-located monoplexers) The protection command is high if and only if any of the following are true:
    - a. Protection Request is high (the intended, i.e. nominal form of protection)
    - b. Beam or RF is high (automatic protection)
    - c. Protection Request has been raised in the last 80 microseconds: one can simply pulse the protection request and then rely on automatic protection. (This provides compatibility with the request format used with the former timing control system).
    - d. Beam or RF has been lowered in the last 5 microseconds (extended automatic protection)
    - e. Line voltage fault (an ac power dip is occurring)
  2. *Beam Command* (sent to the klystron beam modulator)
- The Beam Request is first sent through the PRF Limiter, a block which will ensure the average PRF will not exceed 1.04 kHz. (No more than 16 pulses are allowed between the

ticks of an internal 15.36 msec clock). The PRF-limited Beam Request is next sent through the Duty Factor Limiter, a block that ensures the beam duty factor will not exceed 6.25% (the beam will be truncated if it has been on for a total of 2.099 msec in any interval of length 33.6 msec). The output of this block is the *Granted Beam Request*. Normally, requests are legal and the Granted Beam Request is identical to the Beam Request. Finally, the Granted Beam Request, is OR'd with LOCAL.AND.CW, to form the Beam Command. The transmitter had a seldom used CW mode; setting this unit to "LOCAL" and its Duty Factor selector switch "CW" causes the receiver protection, rf, and beam commands all to be high. (An "CW Enable" toggle switch prevents accidental selection of "CW").

Note: A copy of the Beam Command is also sent to the Low-Level Modulator Chassis "unblank" (i.e. enable) the exciter. (The RF Command provides fast turn on and turn off, but, additional blanking is necessary to provide total suppression of feed-through during receive periods).

**3. RF Command** (sent to the low level RF drive circuits in the Freq. Synthesizer / Low-level Amp chassis and in the Low-Level Modulator chassis).

The RF command is the AND of the RF Request, the Protection Acknowledge signal, and a 2 usec delayed version of the Beam Command. This prevents driving the klystrons until the beam is fully on and, of course, prevents driving the klystrons when the receiver protection is not active. The RF Command is also forced low if a power dip is occurring.

**4. Phase Command**

The Phase Request is simply passed along to the Low-level Modulator chassis. The Phase Command LED on the front panel blinks when the Phase Cmd Request is toggling.

### 17.4.0 Overall Circuit Description

The transmitter commands described above are generated by the logic shown in Figure 2, a block diagram. In this figure, the normal signal paths are shown in bold. The individual blocks are described below

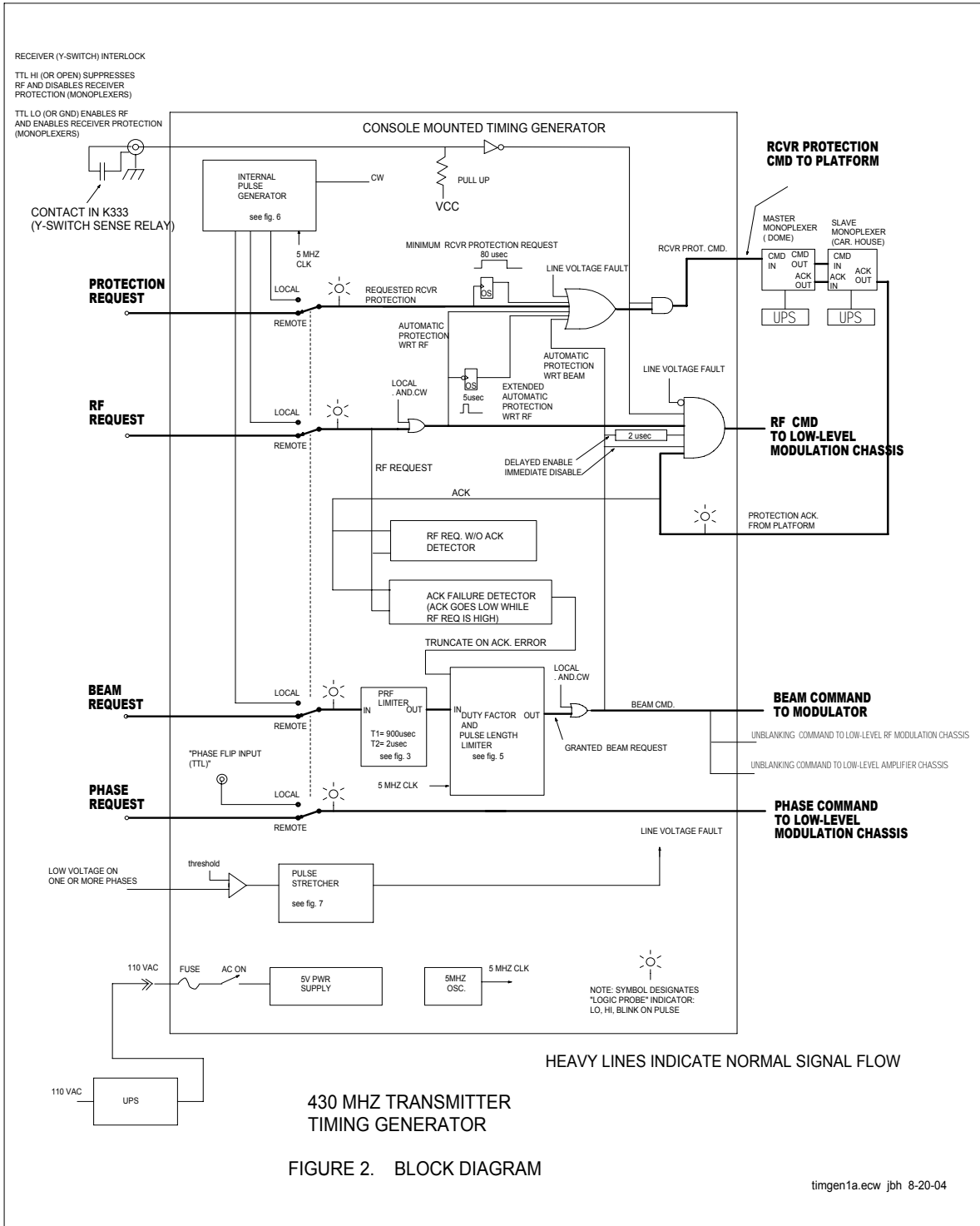

### 17.4.1 PRF Limiter

Figure 3 is a simplified schematic diagram of the PRF Limiter. The 5-bit ripple counter increments on the falling edge of the Beam Request. After 16 counts, Q5 goes high and the flip-flop is reset, turning off the output AND gate. Subsequent Beam Request are therefore suppressed until the next reset pulse arrives to set the counter back to zero. As long as there are never more than 15 pulses between resets, the Beam Request Out will be identical to the Beam Request In. Any time the PRF limiter activates, a red fault indicator LED is lit and latched.

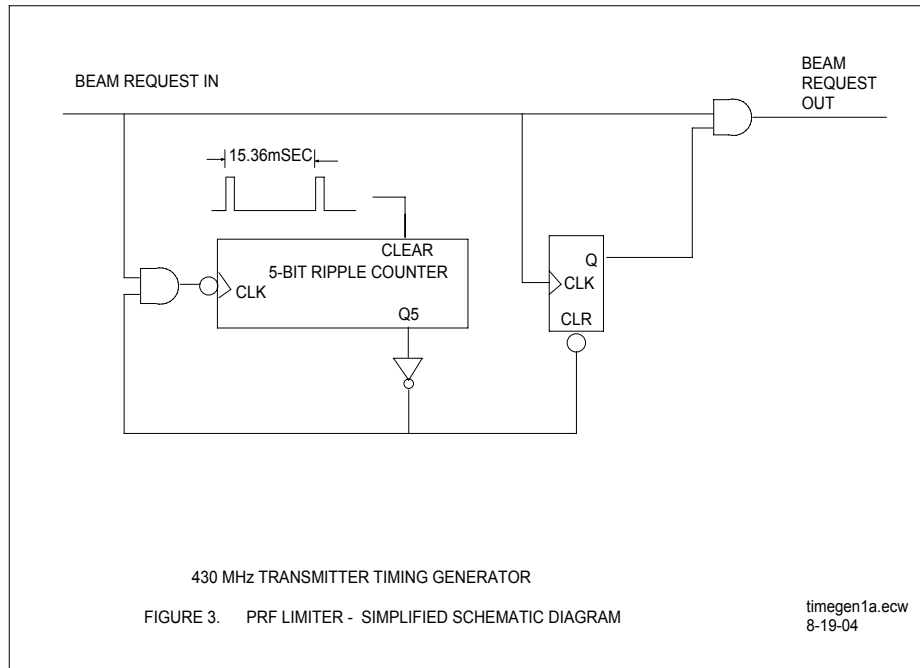

### 17.4.2 Beam Duty Factor Limiter

Figure 4, a simplified schematic diagram of this block, shows the duty factor and pulse width limiter. The circuit has one principle input, BEAM REQUEST, and one output, GRANTED BEAM REQUEST. Note that the heart of this circuit is the flip-flop FF1 and the AND gate U1 at the upper right corner. When FF1 is high, the beam request is granted (gated). In normal operation, FF1 remains high. The Up/Down counter counts down between pulses, usually all the way to zero, where it stops. It counts up at a 5MHz rate during pulses. If the count reaches 10496, FF1 will be reset, turning off the GRANTED BEAM REQUEST. While the GRANTED BEAM REQUEST remains low, the counter counts down at a rate of  $1/15 \times 5\text{MHz}$ . The next BEAM REQUEST will turn FF1 back on. If the counter has reached zero, the new pulse can be as long as 2.099 msec (producing a count of 10496). If the counter has not reached zero, the new pulse must be shorter, or it will be truncated. Thus the average duty factor is forced not to exceed  $1/(1+15)$ , i.e. 6.25%.

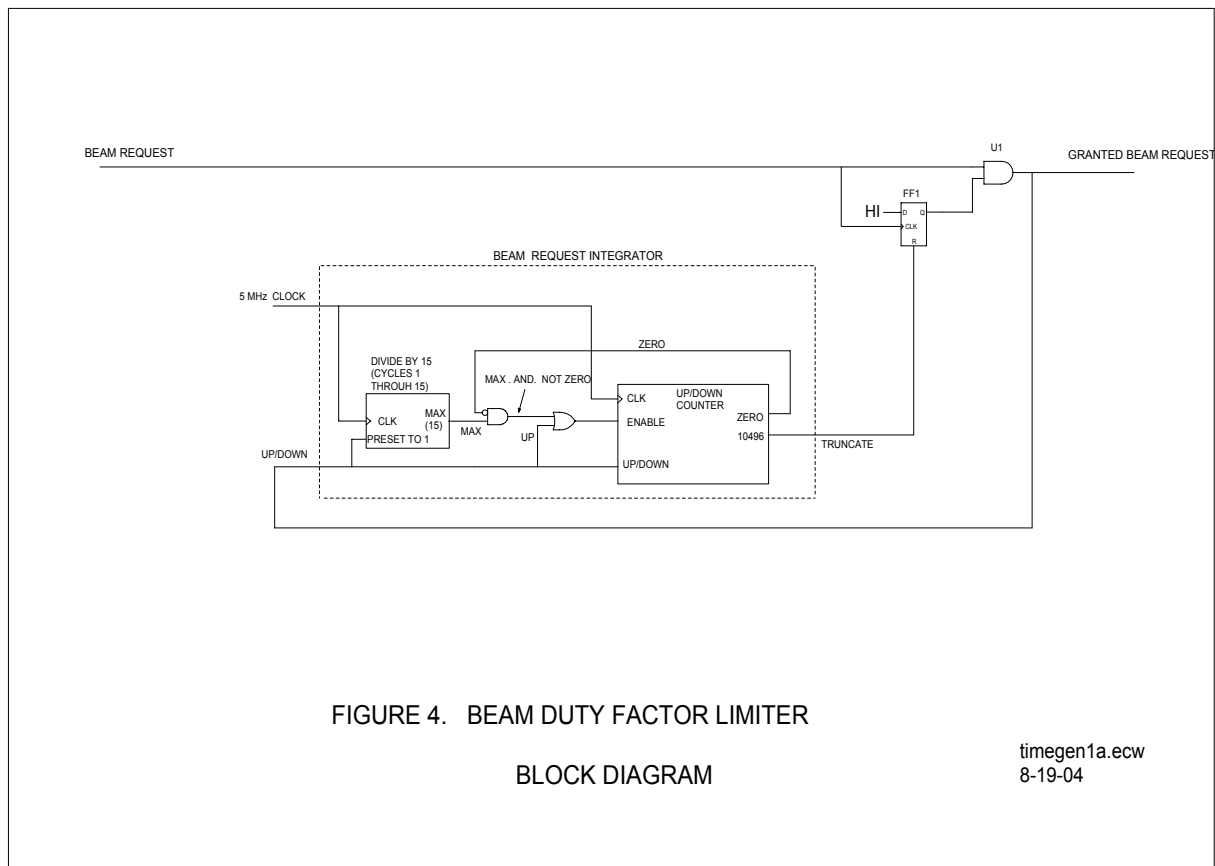

This

module has a secondary input, which, if pulsed, will truncate a pulse by directly resetting FF1. This input is fed from the ACK Failure Detector, which provides a pulse if ACK goes down while RF Request is high, e.g. when there is a fault in the cable taking the Protection Cmd signal to the platform or in the cable bringing the ACK down from the platform.

### 17.4.3 Internal Pulse Generator

This unit produces local versions of the four control pulses, and is used for stand-alone testing

of the transmitter. Refer to Figure 5, a block diagram of the Internal Pulse Generator.

This generator is based on two counters: the PRF counter and the Pulse Length Counter. Both counters are free running; they cycle continuously. The PRF counter, a straight binary counter, is clocked at 1 MHz. Its successively divided outputs are the inputs to a 10-position PRF Selector switch. The selected output rate clocks the Pulse Length Counter, which is a 3-decade counter that cycles continuously from 000 to 999. The same clock is used to clock a D-type flip flop, whose output is the generated pulse. The flip flop is turned on when the counter state is 000 and is turned off when the counter state is 001, 002, ..... 060, which correspond to duty cycles from .001 to .060 (0.1% to 6%). Note that a 0% duty factor (beam off) is also provided. When the duty factor selector is set to 0%, the D input of the flip flop is held continuously low.

The output of the flip-flop is delayed by 24 usec by means of a 24-bit shift register clocked at 1 MHz. The shift register input and output signals are combined in some simple logic to produce the LOCAL

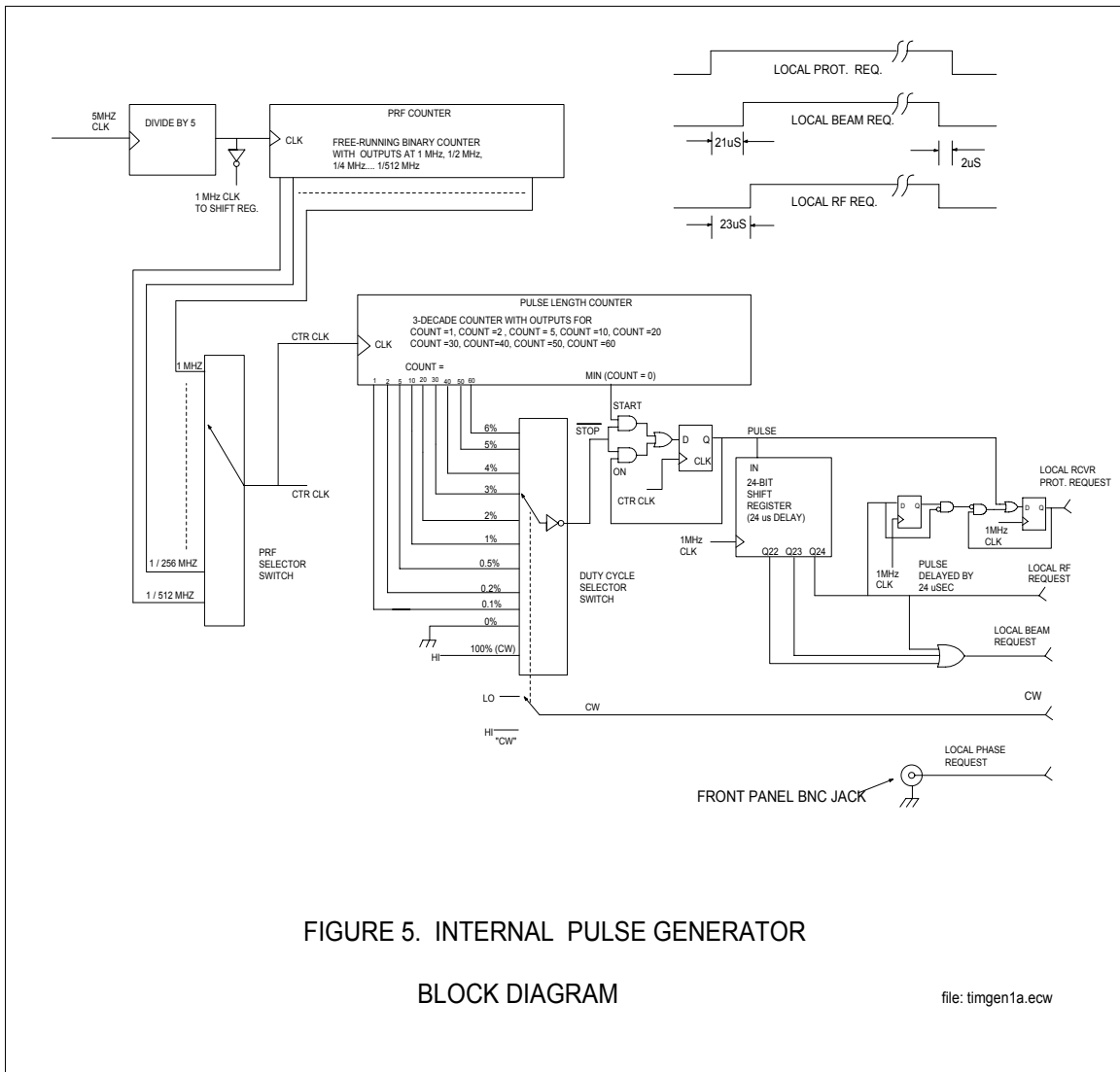

FIGURE 5. INTERNAL PULSE GENERATOR  
BLOCK DIAGRAM

file: timgen1a.ecw



RF REQUEST pulse (which has the selected duty factor), the LOCAL PROTECTION REQUEST pulse, which begins 23 usec earlier, and the LOCAL BEAM REQUEST pulse, which begins 2 usec earlier. The beam and rf requests fall at the same time. The protection request falls 2 usec later. The LOCAL PHASE REQUEST is derived from a front panel BNC jack. For most testing, nothing will be plugged into this jack (no phase modulation).

#### **17.4.4 Power Line Dip Protector**

This circuitry produces a “line voltage fault” signal (1-bit) as soon as any one of the three power line phases falls below a threshold of 85 Vrms. The fault simultaneously blanks the transmitter (suppressing the RF Command), turns off the beam command, and applies receiver protection (turning on the monoplexers). Any sensed brownout is stretched an additional 1.5 seconds, so even the briefest power dip will produce a 1.5 second blanking. Whenever this blanking occurs, a red indicator lamp is lit and latched.

#### **17.4.5 Antenna Interlock**

A rear panel BNC inputs accepts a TTL signal, which, when LOW, inhibits the transmitter (turning off the RF pulses) and disables the receiver protection. This is used for radio astronomy observations where the transmitter must be inhibited to prevent receiver damage and the receiver protection must be removed so that the monoplexer doesn't periodically interrupt the received signal. This signal is provided from the 430 MHz Mode/Protection panel in the receiver racks.

#### **17.4.6 Ack(nowledge) Failure Detector**

Circuitry is provided to detect any instance of the Ack line falling low while the RF Request is high. This would be the case if there is a break or intermittent connection in the cables carrying the Protection Request to the platform or the cables bringing the Acknowledge signal back down from the platform. In the event of such an Ack Error, the pulse is truncated and a red indicator lamp is lit and latched. The monoplexers have built-in pulse stretchers, so, if the problem is in the cabling, the receiver will remain protected for about 20 microseconds after the Ack Error has truncated the transmitter pulse. (Protection is need for an extended interval while the failure indication propagates to the timing generator, the RF cut-off reaches the platform, and even longer, until reflections subside in the long waveguide run).

A similar circuit detects any instance of RF Request going high when Protection Request is low. Such a failure would indicate faulty request timing, and lights a latched error lamp. The design of the unit (see Figure 2) ensures that protection will automatically be added before the RF request is passed to the transmitter as a command.

#### **17.4.7 UPS for the Timing Generator**

This unit is installed with its own UPS, just as each of the two upstairs monoplexer drivers has its own UPS.

### **18. Receiver Protection**

We can count on no more than about 25 dB of isolation from the turnstile junction. Therefore the pulse

power leaving the turnstile's receiver port is about  $2.5 \text{ MW} - 25 \text{ dB} = 7900 \text{ W}$ . The job of the monoplexer is cut this feed through down to, say,  $1 \text{ mW}$  to prevent burning out, or severely overloading, the receiver. This implies a monoplexer attenuation of better than  $69 \text{ dB}$ .

### 18.1 430 Monoplexer - Theory of Operation

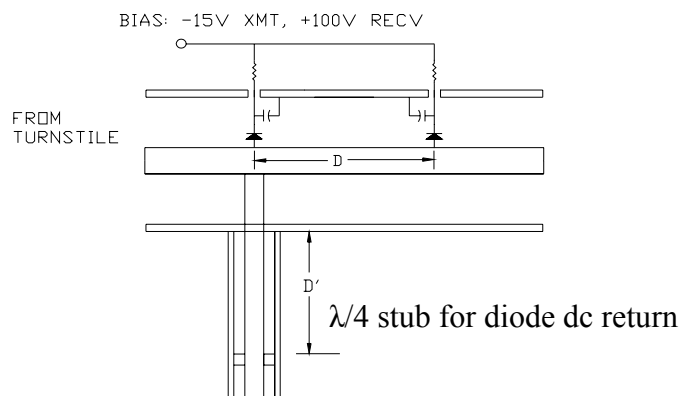

The monoplexer is shown above in simplified form. This device is put at the input to the receiver. When the diodes are forward biased, their resulting low impedance (about  $1/10 \text{ ohm}$ ) shorts the inner and outer conductors of the coaxial feed line. This short reflects the leakage power from the turnstile (about  $1 \text{ kW}$ ) to protect the receiver from burnout.

There are two diode "stations" along a  $50\text{-ohm}$  line, separated by a distance  $D$ . Each station has 4 diodes to provide a better short. If a single diode station provided, say,  $50 \text{ dB}$  of isolation, then adding a second station a quarter wave from the first would increase the isolation to  $2 \times 50 + 6 = 116 \text{ dB}$ . A quarter-wave separation provides the maximum isolation.

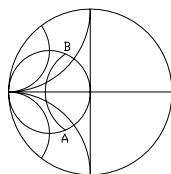

For receiving, the diodes are reverse biased. Their low resistance disappears but they still present a capacitance of about  $2.1 \text{ pF}$ . Four diodes in parallel increase this to  $8.4 \text{ pF}$  which, at  $430 \text{ MHz}$  is a reactance of  $44 \text{ ohms}$ . This reactance, shunted across the  $50\text{-ohm}$  produces a reflection coefficient shown as point  $A$  in the Smith Chart. Moving along the transmission line from point  $A$ , we arrive at point  $B$  (the mirror image of point  $A$  about the  $x$ -axis) where an identical station will bring us back to

the center

of the chart, i.e. eliminate the reflection. If the capacitance had been very small, point A would have been very near the y-axis. The separation on the chart would have been 180 degrees and the physical separation would have been 90 degrees - the separation that gives the best isolation when the diodes are in the transmit state. No compromise is made; the separation is determined by the angle between *A* and *B* so that there will be no mismatch on receive. For our 8-diode monoplexer, the separation is only 31 degrees.

We can analyze the circuit to determine the isolation as a function of the diode ON resistance and the distance between the diode stations. The equivalent circuit is shown below at the left. A simplified version is shown at the right.

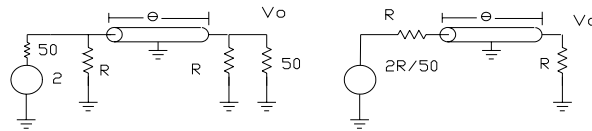

The source is made to be 2 Volts so that the output voltage,  $V_o$ , will be 1 Volt when the resistors  $R$  are infinite in value (no attenuation). Since the  $R$  will be much less than 50, the circuitry to the left of the transmission line has a Thévenin equivalent voltage source of  $2R/50$  and an impedance of  $R$ . This Thévenin equivalent is shown in the simplified circuit. Again, since  $R \ll 50$ , we can ignore the 50 ohm load (the receiver) in calculating the output voltage. The output voltage can be calculated as follows: The cable and the resistor at the right-hand end present an impedance given by  $Z = 50(R + 50 j \tan \theta) / (50 + R j \tan \theta)$ . The current flowing into  $Z$  is given by  $I = (2R/50) / (Z + R)$ . The power delivered to  $Z$  is given by  $P_{wr} = |I|^2 \text{Re}(Z)$ . This power is equal to  $|V_o/R|^2 \text{Re}(R)$ . Solving for  $|V_o|^2$  we find

$$|V_o|^2 = |(2R/50)/(Z+R)|^2 |R|^2 \text{Re}(Z)/\text{Re}(R)$$

where  $Z = 50(R + 50 j \tan \theta) / (50 + R j \tan \theta)$ . In this formula, the value of  $R$  can be complex, to include diode reactance. The attenuation is given simply by  $10 \log(|V_o|^2)$  and is plotted below in dB vs. diode station separation for three values of  $R$ .

file:430mpxr2.mcd

$\theta := 0, 1..4$

$$Z(R, \theta) := 50 \cdot \left( \frac{R + j \cdot 50 \cdot \tan(\theta)}{50 + j \cdot R \cdot \tan(\theta)} \right)$$

$$P_{wr}(R, \theta) := 10 \cdot \log \left[ \left( \left| \frac{\frac{2 \cdot R}{50}}{R + Z(R, \theta)} \right| \right)^2 \cdot \frac{(|R|)^2}{\text{Re}(R)} \cdot \text{Re}(Z(R, \theta)) \right]$$

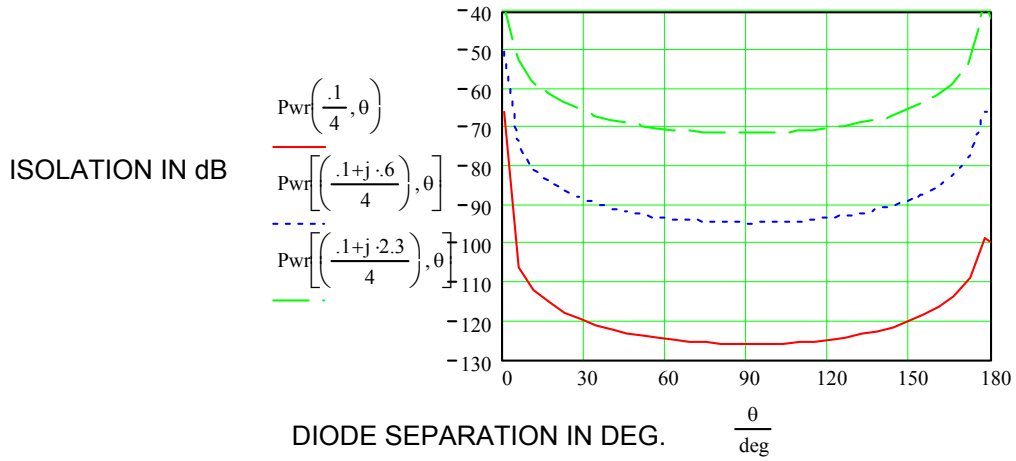

When the diode impedance is taken as  $0.1/4 + j0$  (four diodes of  $0.1 + j0$  ohms in parallel, as at each end of our 8-diode monoplexers), the theoretical isolation reaches 120dB. If we add 0.6 ohms of reactance to each diode, corresponding to the 630pF bypass capacitors (metal segment plate with mica insulation), the isolation drops to 88dB. The measured value, however, is about 66 dB. As shown in the third curve, this is the value we would expect to measure if each diode had a reactance of 2.3 ohms. This corresponds to an inductance of only 0.85nH, which could be attributable to the 1/4" length of the stud-mounted diodes. It could also be attributable to the fact that the diodes don't directly contact the center conductor of the coaxial line. Instead, at each diode station, the center conductor becomes a thin disc, i.e. a radial transmission line. The diodes contact the disk at a radius that is about twice that of the center conductor. This section of radial transmission line might account for the apparent reactance.

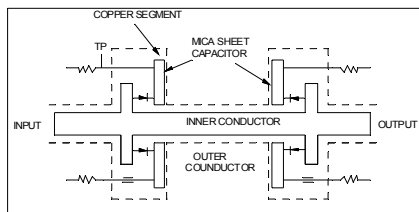

We have no documents describing the original monoplexer design, which was done at Sylvania in Waltham Ma. Did the designer take into account the radial transmission line and attempt to resonate out its impedance by carefully selecting the thickness of the mica insulation in the bypass capacitors?

### 18.1.1 Monoplexer power handling capability

The monoplexers should be able to withstand an incident wave of 50kW cw, and maybe up to 800kW with a 6% duty factor. Power handling is determined by the input diode station, where four diodes in parallel short the input line. If the incident power is  $P_{INC}$ , the current through the short will be given by  $I_{RMS}^2 = 4 P_{INC} / Z_0$  where  $Z_0$  is the impedance of the line (50 ohms) and the factor of 4 is due to the fact that the reflected wave produces a current equal to the incident current. Each diode, when forward biased, has an RF resistance of 0.1 ohms, so the resistance of the four diodes in parallel is 0.025 ohms. The maximum average power dissipation of each of these stud-mounted diodes is 25 watts, for a total dissipation of 100W. Putting this together, we have  $.025 I_{RMS}^2 = 100$  or  $.025(4 P_{INC} / Z_0) = 100$ , from which  $P_{INC} = 50,000$  cw or  $50,000/.06 = .83$ MW when pulsed with a 6% duty factor..

### 18.1.2 Failure modes

The monoplexers have had frequently failures. There are three obvious failure modes: *a.* the turnstile isolation is too low, maybe only momentarily due to a stray reflection near the feed , overloading the monoplexer, *b.* the control circuitry has failed to switch the monoplexer into the isolation state when a transmitter pulse occurs, and *c.* the monoplexer driver has not applied enough bias current to the diodes to reflect safely the incident power. Nominally we protect against *b.* and *c.* by generating an *acknowledge* signal at the monoplexer. This signal is high when the monoplexer is in the protective state as determined by the total current drawn by the PIN diodes. The acknowledge signal is sent back to the transmitter where the control circuitry is designed to suppress the transmitter pulse unless or until the acknowledge signal is high.. New pulse control circuitry (see section 17), together with a UPS should make this protection more reliable. As for Mode *a.*, we could (and should) monitor the power incident on the monoplexers. Directional couplers can provide power samples. These samples can be processed with a peak hold power detector. We could also install a second peak hold detector at each monoplexer to measure the (nominally zero) that has occurred while the monoplexer is in the protect state. This would detect failures from Mode *b.*

Finally, we could test the monoplexer isolation at the beginning of every radar run using a test signal.

The test signal should be attenuated by about 70 dB when the monoplexer is commanded on. One possibility for the test signal is the birdie generator at the bottom of the bowl. Another possibility is to inject a cw signal into the wave guide downstairs. This has the added advantage of testing the combined isolation of the turnstile and the monoplexer.

### 18.1.3 Monoplexer current vs. voltage

Voltage	8 diode monoplexer current	6 diode monoplexer current	4 diode current (input stations, output station of 8-diode monoplexer)	2 diode current (output station of 6-diode monoplexer)
1.00	0.63	0.47	0.32	0.16
1.20	1.04	0.78	0.52	0.26
1.30	1.27	0.95	0.64	0.32
1.40	1.49	1.12	0.75	0.37
1.50	1.72	1.29	0.86	0.43
1.90	2.64	1.98	1.32	0.66
2.10	3.11	2.33	1.56	0.78
2.30	3.57	2.68	1.79	0.89
2.50	4.09	3.07	2.05	1.02

### 18.2 Monoplexer Drivers

The driver circuit must apply a positive voltage (+150 is used) to put the monoplexer into its receive state, and a negative voltage (-5v) to put the monoplexer into its protect state. The positive voltage need not supply current, except while the monoplexer is being pulled up. But, since this

pull-up must be fast (approx 1 usec) if short range targets are to be detected, the pull-up current can be appreciable, several amps. Thus a substantial pull-up transistor is needed. The negative voltage need not be applied quickly (except that extremely slow application would require that the IPP be increased) but, since considerable current is required from the negative supply (the PIN diode current), the pull down transistor must also be substantial.

High power mosfets are mostly N channel devices so it seems advantageous to use identical N-channel devices for pull-up and pull-down.

### **18.2.1 Monoplexer driver: theory of operation** (Refer to the schematic diagram: 430mxdr6.ecw)

The driver has three circuit sections: a switch section, a simple 150V power supply, and a logic section. It also contains a commercial 5V power supply.

#### Switch Section

The Switch section contains totem pole circuit in which Q2 pulls the monoplexer up to +150V or Q5 pulls the monoplexer down to -5 volts. While Q5 is off, diode D2 opens, letting R6 turn on Q2 to pull the monoplexer up to 140 volts. A push-pull complementary pair, Q3 and Q4, drives the gate of Q5. Fast turn-on of Q2 requires that R6 have a low value, but too low a value results in high dissipation when the transmitter duty factor is 100%; in this situation there is a steady 160 V across R6. The transistor Q9 is in parallel with R6, and is used to speed up Q2's turn-on. The gate signal for Q5 is capacitively coupled to Q9's base so that the signal that turns off Q5 will help turn on Q2.

#### 150V Supply

The 150V supply simply back-biases the monoplexer, putting the monoplexer into its pass through state for receiving.

#### Logic Section

The monoplexer is commanded to the blocking state (receiver input shorted to ground) by illuminating the optical fiber input *Command In*. For compatibility with the old drivers, a -3 volt logic *Alternate Command In* is provided. If the *Command Input* is used, the *Alternate Command* input should be left disconnected or at zero volts. When the *Alternate Command* input is used, the *Command In* should be disconnected or left un-illuminated.

A fiber *Command Out* is provided so that the command can be daisy-chained to the second monoplexer from the first monoplexer (the "first" is the one that receives the command from the control room and sends the *Acknowledge* signal back to the control room). For compatibility with the old drivers, a -3V *Alternate Command Out* is also provided.

A fiber *Acknowledge Out* and a -3V *Alternate Acknowledge Out* are provided to signal the transmitter that receiver protection is active (current is flowing in the monoplexer PIN diodes). R19 sets the threshold of the current detector. It should be adjusted so that, with normal PIN diode current (1/2 amp/diode), the differential voltage at the input of U7 is about .15 volt. If a single

diode stops conducting, the differential voltage will change by  $.5 \text{ amps} \times .2 \text{ ohms} = .10 \text{ volt}$ . More than one open diode will not be tolerated; the acknowledge pulse will not be produced.

A one-shot is provided to keep the monoplexer on by approximately 20 microseconds after the command pulse falls. In the event that the command pulse fails and falls, the protection is extended 20 microseconds. The transmitter will turn off before the one-shot times out because the acknowledge signal is actually the AND of ‘PIN diode current’ and the command signal.

When both drivers are used, the second one (slave) passes its acknowledge signal back to the first driver where it is ANDed to produce the acknowledge signal fed back down to the transmitter. Inspection of the schematic diagram on the front panel will show that the switch on the first driver must be set in the *Master* position while the switch on the second driver must be set to the *Slave* position. A commercial linear 5V , 6A power supply inside the driver chassis supplies -5 volts. One of our present monoplexers uses 6 PIN diodes and requires 3 amps of forward current. Our other monoplexer uses 8 diodes and requires 4 amps.

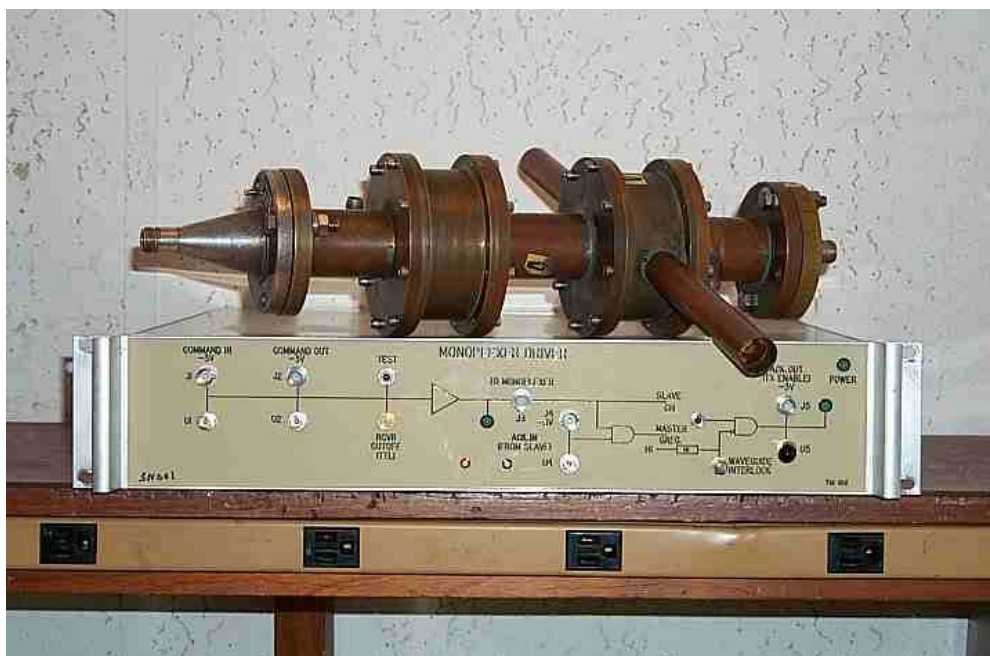

Monoplexer and monoplexer driver. The side arms at the input diode station have adjustable  $\lambda/4$  shorts which provide some tunability and ground the center conductor for dc to provide a return path for the current in the PIN diodes.



**19: Waveguide run to platform, rotary and linear joints**

The waveguide run from the transmitter to the platform is approximately 1300 ft. long and consists of about 180 flanged sections - straight sections, bends, and corrugated flexible sections. The table below describes the components and their quantities that make up the wave guide run from the transmitter to the slotted line for the carriage house. This table corresponds to the original system; the addition of the power splitter, the second slotted line, and the half-height waveguide run from the dome linear joint to the feed room is not included. (to be done). Note that the length is missing for some of the components (bends).

SUMMARY OF WAVEGUIDE RUN TO CARRIAGE HOUSE

SEE DWG.

file: waveguide.xls

SYMBOL	DESCRIP.	LENGTH (IN)	QTY	QTY X LENGTH
A	STRAIGHT	143.625	85	12208.125
B	STRAIGHT	125.625	1	125.625
C	STRAIGHT	68.21875	1	68.21875
D	STRAIGHT	132.875	1	132.875
E	STRAIGHT	60	2	120
F	STRAIGHT	53.5	1	53.5
G	STRAIGHT	40	1	40
H	STRAIGHT	108	1	108
J	STRAIGHT	18	3	54
K	STRAIGHT	52.5	1	52.5
L	STRAIGHT	24	1	24
M	STRAIGHT	57.5625	1	57.5625
N	STRAIGHT	67	1	67
P	STRAIGHT	75.75	1	75.75
Q	STRAIGHT	71	1	71

R	STRAIGHT	81.25	7	568.75
S	STRAIGHT	71.75	1	71.75
Y	STRAIGHT	59.8125	1	59.8125
U	STRAIGHT	120	1	120
V	STRAIGHT	16.5	1	16.5
W	STRAIGHT	47.75	1	47.75
X	STRAIGHT	68.875	1	68.875
Y	STRAIGHT	9.625	1	9.625
Z	STRAIGHT	12.5	1	12.5
AA	STRAIGHT	12.4375	1	12.4375
BB	STRAIGHT	9.6875	1	9.6875
CC	STRAIGHT	13.5	1	13.5
DD	STRAIGHT	14.125	1	14.125
EE	STRAIGHT	23.25	1	23.25
FF	STRAIGHT		1	
GG	STRAIGHT	66.5625	1	66.5625
HH	STRAIGHT	78	1	78
JJ	STRAIGHT	32.25	1	32.25

flex	FLEX SECTION	16	27	432
ZA	H BEND (MITER)	15	5	75
ZB	E BEND (SWEEP)	24	10	240
ZC	E BEND (SWEEP)		1	
ZD	H BEND (MITRE)		1	
ZE	H BEND (MITRE)		1	
ZF	H BEND (MITER)		3	
ZG	E BEND (SWEEP)		1	
ZH	E BEND (SWEEP)		1	
ZI	E BEND (SWEEP)		1	
ZJ	E BEND (SWEEP)		1	
ZK	E BEND (SWEEP)		1	
ZL	E BEND (SWEEP)		1	
ZM	E BEND (SWEEP)		1	

total length in ft 1269.210938  
no. pcs. 181

**Sequence of waveguide components, beginning from the transmitter**

(The order is component number; code, component number; code, etc. Note that flex sections are not numbered).

1 ZA Flex

2-3 A, 4 B, 5 ZB, Flex  
 6 A, 7 C, Flex  
 8 ZC, 9-11 A, 12 D, Flex  
 13 ZD, 14-20 A, 21 Zb, 22 E, 23 ZE, Flex  
 24 F, Flex  
 25 ZF, 26 E, Flex  
 27 ZG, 28-30 A, 31 G, 32 A, 33Hj, 34 J, 35-43 A, Flex  
 44 K, 45 A, Flex  
 46 L, 47-49 A, 50 ZH, Flex  
 51-52 A, 53 M, 54 ZB, 55N, 56 Zb, 57 J, 58 ZA, Flex  
 59 P, Flex  
 60 Za, 61 A, Flex  
 62 Q, 63 A, Flex  
 64067 A, Flex  
 68 R, 69-74 A, Flex  
 75 R, 76-81 A, Flex  
 82 S, 83 A, Flex  
 84-85 R, 86-89 A, Flex  
 90 r, 91-96 A, Flex  
 97 R, 98-103 A, Flex  
 104 R, 105-110 A, Flex  
 111-115 A, Flex  
 116 ZB, 117 T, 118 AB, 119 U, 120 ZI, 121 V, 122 A, 123 ZJ, 124 ZB, Flex  
 125 A, 126 W, Flex  
 127 ZB, 128 A, Flex  
 129 ZK, 130 ZA, 131 J, 132 ZA, 133-135 A, 136 X, Flex  
 137 ZL, 138 Y, 139 Z  
 Rotary Joint  
 140 AA, 141 BB, 142 ZM, 143 CC, 144 AB, 145 DD, 146 EE 147 EE 148 GG  
 149 A, 150 HH, 151 ZB, 152 JJ, 153 ZF, Flex  
 154 ZF  
 Slotted line

4            B  
 5            ZB  
 FLEX  
 6            A  
 7            C  
 FLEX

The total length of the waveguide is approximately 1400 ft, depending on the position of the carriage house. The theoretical loss of 1400 of aluminum WR2100 is 0.48 dB. We measured the loss from the transmitter room to the carriage house to be 1.25 dB, leaving 0.77 dB to be accounted

for in the harmonic filter, the corrugated waveguide sections, the rotary joint, the five-probe tuner, the slotted line, and the traveling collector.

Waveguide runs above the catwalk from the base of tower T12 to the platform.

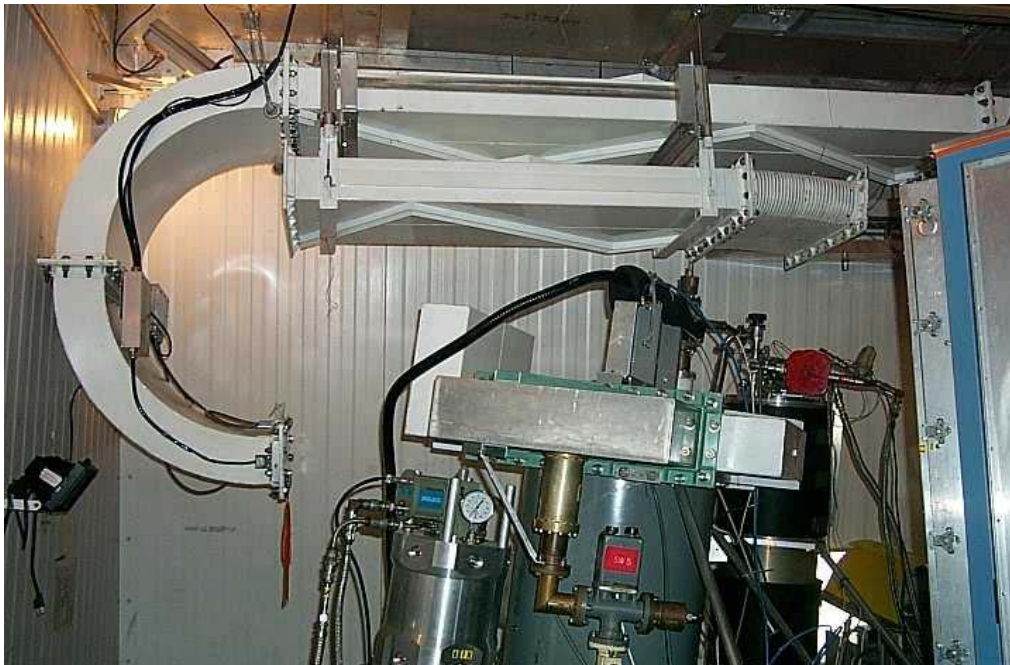

Half-height transmitter waveguide connection in the dome. For radar operation, the straight/flex section stowed below the ceiling waveguide run is lowered and bolted into place, connecting the 180-degree bend to the turnstile.

## 19.1 Rotary Joint

The rotary joint, at the center of the platform, has been absolutely reliable since it was installed. It is actually a dual-channel rotary joint, handling both the WR2100 waveguide and a 9" coaxial line (which was needed when a high power 40 MHz transmitter was also in service). The electrical design is fairly conventional: the TE<sub>10</sub> mode in the rectangular waveguide is transformed to the TM<sub>01</sub> mode in the circular part of the joint and then back to TE<sub>10</sub> at the output rectangular waveguide. The fact that the circular waveguide has a concentric pipe at its center (the outer conductor of the coaxial line) hardly changes the TM<sub>01</sub> mode, whose electric field lines are radial, whether the circular guide is empty or has a round conductor along the center line, making it a coaxial waveguide. (Note that while the waveguide is coaxial, the mode used is the TM<sub>01</sub> waveguide mode and not the TEM coaxial mode).

Grease fittings are provided for the ball bearings, and it appears that these have used regularly.

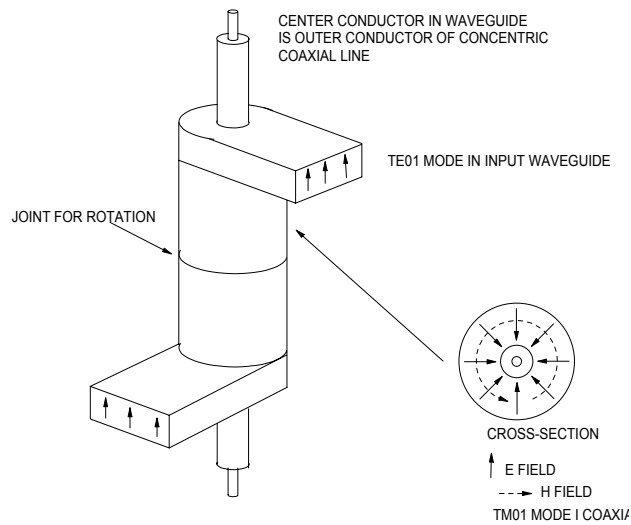

Dual Channel Rotary Joint - Waveguide and coax

The circular waveguide section is a coaxial waveguide. The center conductor forms the outer conductor for a coaxial TEM mode second channel. Choke joints and bearings not shown.

At present, only the waveguide portion is used; the center conductor has been removed from the coaxial line, leaving an open hole through the center post of the rotary joint.

## 19.2 Linear Joints

The linear joints extend from the central power divider to the dome and the carriage house. Each linear joint is made of a slotted waveguide and a traveling probe. The slotted waveguide has the same rectangular dimensions as WR2100, i.e. 21" x 10.5". But one broad wall contains a skirted slot, wide enough to pass a half-height waveguide (see figure below).

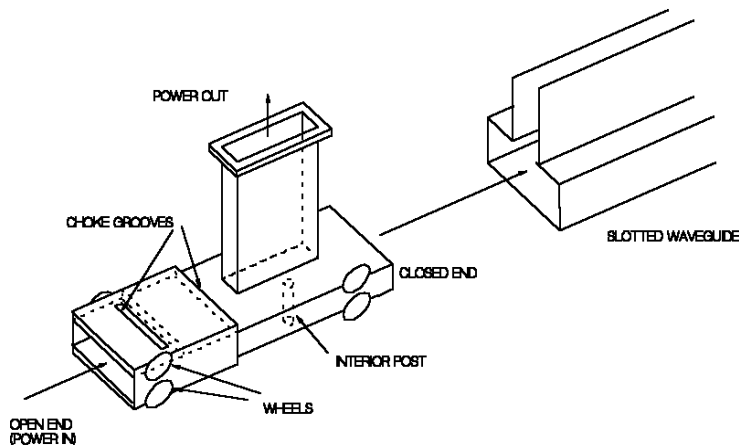

Linear Joint: Slotted waveguide with traveling probe.  
Note the figure is inverted; the output wave guide points downward, through the slot.

The probe is mostly within the slotted waveguide, taking the form of a wheeled waveguide component, which is both a right angle bend and a 90-degree twist. (Note that the figure is inverted; the half-height “power out” waveguide and the slot point downwards into the dome or carriage house). The downward pointing output waveguide is attached to the dome or carriage house so that, as the azimuth angle is changed, the probe is pushed or pulled along inside the slotted waveguide.

Since the slot is on the centerline of the waveguide, something must be included to break the symmetry between the input and output guides. Otherwise no power would be transmitted through the device. (The up/down electric field lines in the input waveguide wouldn't be able to decide whether to point left-to-right or right-to-left in the output waveguide). An interior post at one side of the output waveguide serves to break the symmetry and can be positioned so that there is no reflection at all. Nevertheless, an inductive tuning post is installed in the output waveguide so that the device can be fine tuned.

Double choke joints at the top and bottom of the input section prevent blow-by.



Unpacking the collector (the moving part of the linear joint).



Collector (upside down) Main body and output stack are half-height waveguide. Input scoop is a  $\lambda/4$  matching transformer. Choke joint cavities at top and bottom of scoop prevent blow-by.

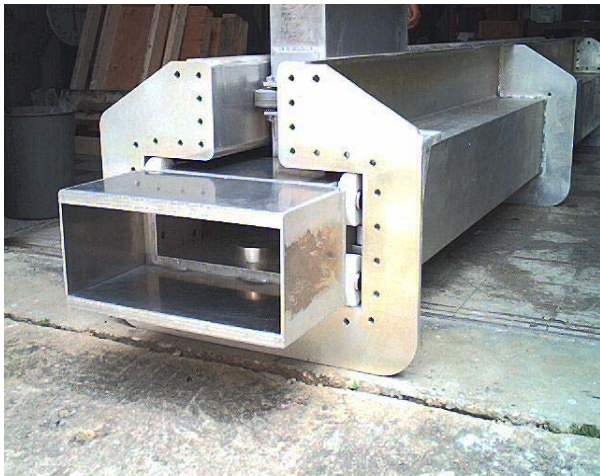

Collector rolls on polypropylene wheels inside slotted waveguide. Wheel well reflections are canceled with hockey puck post.





START OF SLOTTED WAVEGUIDE  
RUN TO THE DOME

START OF SLOTTED WAVEGUIDE  
RUN TO THE CARRIAGE HOUSE

Mitered right angle waveguide bends beneath the power splitter feed the slotted waveguides for the dome and the carriage house.

### 19.3 Waveguide Reflections

In most transmitter/feed line/antenna situations, care is taken to eliminate standing waves, in order to avoid extra feed line loss or voltage breakdown. Feed line loss is usually not a problem; for a fixed amount of radiated power, a VSWR of 2:1 only increases a line's loss by 1/8 over the loss with a perfect 1:1 VSWR. Our system should normally have a VSWR lower than 2:1. As for breakdown, our WR2100 waveguide sections can handle many tens of megawatts, but some other components, such as the linear joints, operate with much lower margins, which is one reason for us to keep standing waves low. Another reason is that the klystrons can be damaged by quite small amounts of reflected power. The EH tuner at the transmitter output lets us present the klystrons with a reflectionless load - as long as the feed is at a fixed azimuth angle. However, an reflections produced out past the linear joint will change in phase as the feed moves along the azimuth arm. Thus the EH tuner would have to be adjusted continuously if the azimuth angle is changing - not a practical solution.

Most of our waveguide system consists of straight sections, gentle curves, and tuned miter bends, which should be essentially reflectionless. The potential spots for reflection are the rotary joint, the transition from straight waveguide into slotted waveguide, the "collector" that travels in the slotted guide, and the turnstile/feed antenna combination. The collectors have been carefully tuned in the lab to minimize reflection, since any reflection from them will change in phase as the collector moves, as explained above. For the same reason, the reflection from the turnstile/horn should be made as small as possible. Simple tuners in the carriage house and dome would permit this, but are not used at present. The only tuner on the platform is a 5-stub tuner at the transition from the standard waveguide to the slotted waveguide.

Note also that our system is not equipped with a directional coupler at the downstairs end of the waveguide, just after the EH tuner. Such a coupler should be installed as a monitor, so we can readily detect the presence of a large reflected wave, as would be produced, for example, by a broken flex section.

### 19.4 5-Probe Tuner

The 5-probe tuner (at the input to the slotted waveguide) consists of a length of waveguide having five capacitive probes, mounted at intervals of about  $3/8 \lambda$ . Moderate amounts of reflection can be eliminated with such a device with only modest penetration of each probe, so the device can handle high power. (Textbook double probe tuners can require very large insertion depths to cancel only small reflections and thus have limited power handling capability). Considering the action of this tuning device as plotted on a Smith Chart, it seems that one can use the following tuning procedure: Begin with all the probes withdrawn. Then, starting at the load end, each probe is adjusted in sequence to minimize the reflection as seen at the input. If the reflection happens to be equivalent to a shunt capacitance at the load end, the first probe will be left all the way out.

## Section 20: Platform power divider

This 3-port device is a junction between the transmitter waveguide from downstairs, the waveguide going to the Gregorian dome, and the waveguide going to the carriage house. It provides an infinitely variable splitting ratio; any desired fraction,  $f$ , of the power can be sent to the dome and the remainder,  $(1-f)$ , will go to the carriage house. As long as there are no reflections in the dome and carriage house waveguides, the splitter will present a matched load to transmitter waveguide. Figure 20.1 shows how two adjustable shorts are used to control the power division ratio.

**Caution:** When the splitter is set at one extreme, so that the power goes nominally just to the carriage house, we still take the precaution of bolting a plate over the open waveguide as it enters the dome. Note that the waveguide run between the splitter and this plate will act as a high Q resonant cavity if its electrical length, as determined by the position of the dome along the elevation rail, is an odd number of quarter wavelengths. In this case, even with the splitter set for the carriage house, a large standing wave can be present in this line. Workers near the slotted part of the line could be exposed to excessive radiation. This is one of the reasons that personnel should be off the platform when the 430 radar is running..

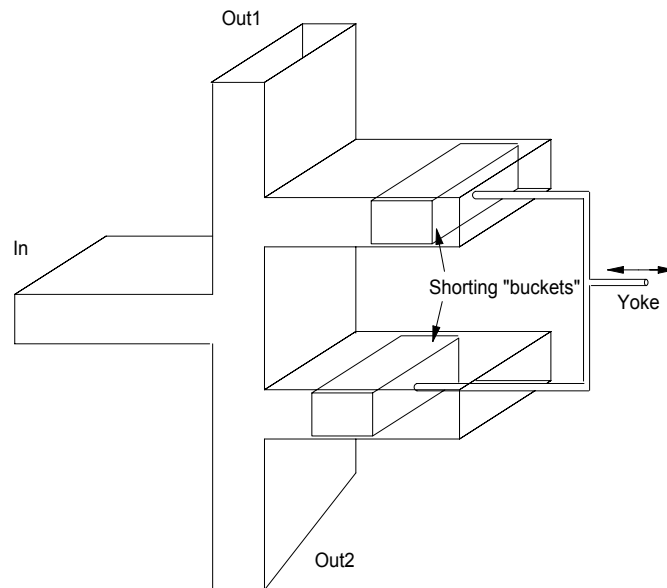
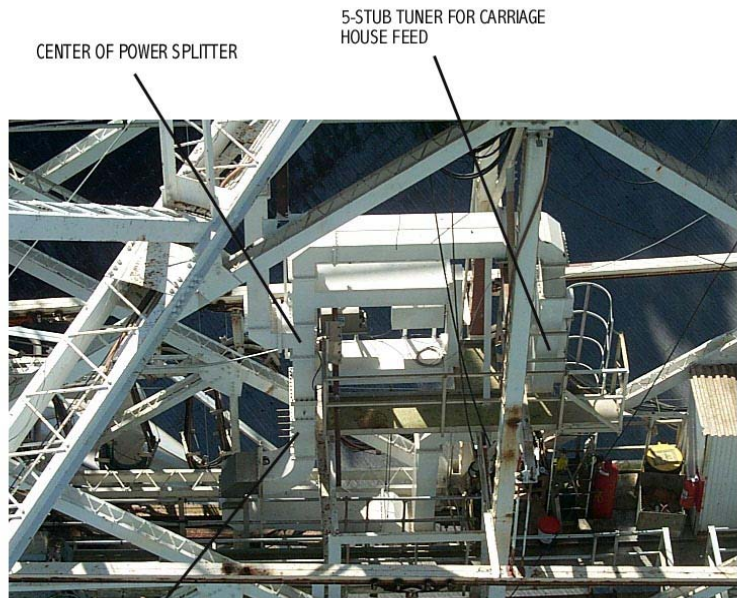

Figure 20.1 Infinitely-Variable Waveguide Power Splitter

This splitter is made of so-called waveguide *series Tees* ( E-plane Tees). If one imagines the waveguides to be parallel wire transmission lines, with the wires running down the centers of the broad walls, these T's can be seen to be series rather than shunt connections. An equivalent circuit is shown below in Figure 20.2, with ordinary open wire transmission lines in place of the waveguide sections.



Power splitter and 5-probe tuners amid structural beams on the platform.

5-STUB TUNER FOR DOME FEED

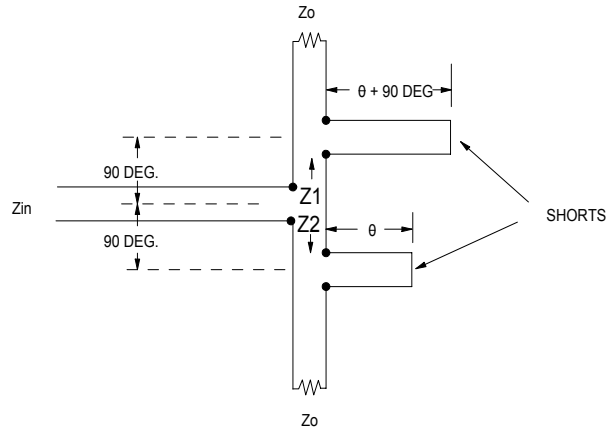

Figure 20.2 Equivalent Transmission Line Circuit

Looking at the figure, we see that the input impedance is the sum of  $Z_1$  and  $Z_2$  because of the series connection of the input T. Each of the arms is a 90-degree section, terminated by a load in series with a stub. The impedance of the bottom arm's termination is therefore  $Z_o + j Z_o \tan(\theta)$  and the impedance of the top arm's termination is  $Z_o + j Z_o \tan(\theta + 90)$ . The impedances  $Z_1$  and  $Z_2$  are the reciprocals of the top and bottom termination impedances, inverted by the 90-degree sections of line. Thus we can write

$$Z_{in} = Z_1 + Z_2 = \frac{Z_o}{1 + j \cot \theta} + \frac{Z_o}{1 - j \tan(\theta)} = Z_o, \quad 1)$$

where we have used the identity  $\tan(\theta + 90) = -\cot(\theta)$ . Note that  $Z_{in}$  is identically equal to  $Z_o$  for any value of  $\theta$ ; the device presents a perfect match.

Since the input impedance is constant, independent of  $\theta$ , the current will be independent of  $\theta$ . The power delivered to the top and bottom leads will be proportional to the real parts of  $Z_1$  and  $Z_2$ . Thus we can write

$$P_1 = \frac{1}{1 + \cot^2 \theta} = \cos^2 \theta \quad 2)$$

and

$$P_2 = \frac{1}{1 + \tan^2 \theta} = \sin^2 \theta. \quad 3)$$

which are plotted below in Figure 20.3

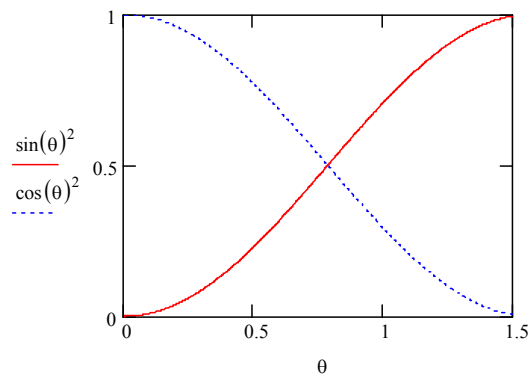
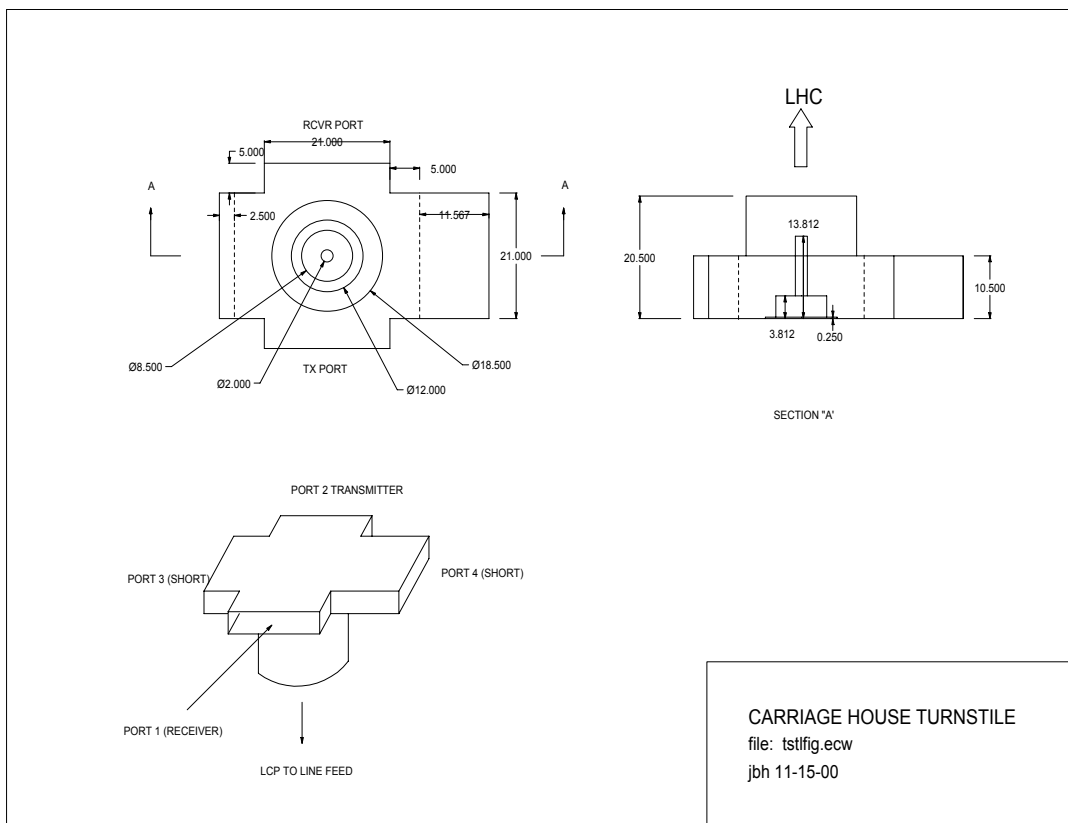

Figure 20.3 Dome and Carriage House power vs. power divider's short position

## 21. Turnstile Junctions (passive diplexers)

### 21.1 Basic operation

The transmitter waveguide connects to one of the four side ports of the turnstile junction. The adjacent side ports are terminated with shorts whose lengths differ by  $\lambda_{\text{guide}}/4$ . Power flowing into the transmitter port exits entirely from the circular waveguide port and is circularly polarized. (i.e. the two orthogonal TE<sub>11</sub> output waves differ in phase by 90 degrees). None (ideally) of the transmitter power leaks out the receiver port, so the receiver will not vaporize. The circular waveguide is connected directly to the feed horn (at the dome side) or to the line feed (at the carriage house side). Return signals (echos from the ionosphere or from other single reflection targets) will have the opposite sense of circular polarization. As they enter the turnstile from the circular waveguide, their power is steered entirely to the receiver port (the side port opposite the transmitter port).



In practice it is impractical to achieve more than 25 or 30 dB isolation between transmitter and receiver ports. With 25 dB isolation and 2.5 MW into the transmitter port, 7905 watts will exit the receiver port, so additional receiver protection is needed. This protection is provided by a PIN diode *monoplexer*, which, when forward biased by the *monoplexer driver*, effectively shorts the transmission line into the receiver, reflecting the several 7.9 kilowatts of leakage back into the turnstile junction before it can reach the receiver.

## 21.2 Theory of turnstile operation

The device was invented and patented by Robert H. Dicke, who fully described its operation in Principles of Microwave Circuits, R.H. Dicke and E. M. Purcell, Rad Lab Series, Volume 8. The circular port supports two orthogonal modes, these modes are indicated on figure below as "Port 5 and "Port 6". (The arrows indicate the electric field direction for these modes. At the rectangular ports, there is only one mode possible, and its electric field is perpendicular to the broad wall of the guide). If one begins with the bare turnstile, i.e. the rectangular and circular waveguides structure, it will be found that power applied to a side port will appear at the other side ports and also at Port 5 or Port 6.

(Note, for example, that from symmetry, power applied to Port 1 cannot exit Port 5). However, one can "tune" the device by inserting a structure of concentric posts, as shown in the preceding figure. With the appropriate tuning structure, the junction will have the following properties:

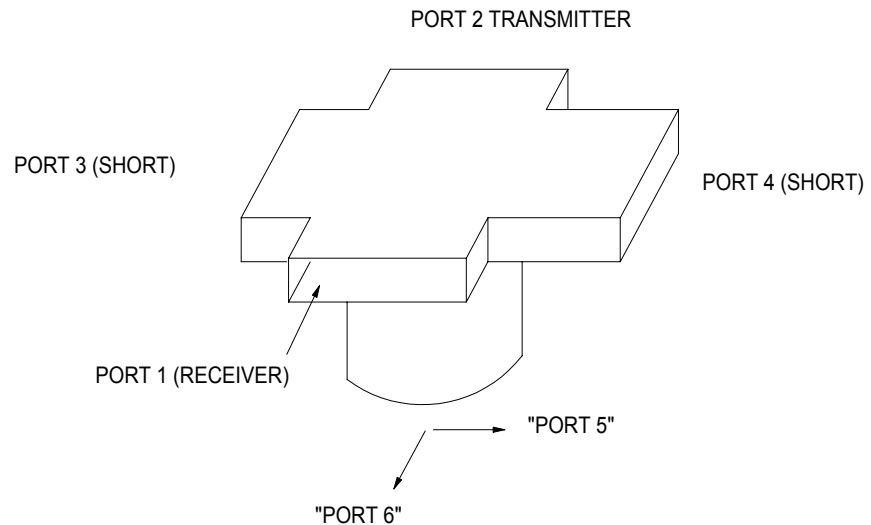

1. All ports will be matched, i.e. none of the power incident on any port will be reflected, providing the other ports are connected to matched loads.

2. Power incident on a side port will split three ways: 25% will flow to each adjacent side port and 50% will flow to either Port 5, or Port 6, as explained above. The opposite side port is isolated: no power flows to it..

Suppose we have built and tuned a turnstile junction. We now install shorts on the two unused sidearms and we make the length of these shorts differs by 90 degrees. Now we apply power to the transmitter port. Half this power proceeds out Port 6, as discussed above. One quarter of the power goes to each shorted side port and is reflected back into the turnstile. The reflections, as they reenter the turnstile, differ in phase by 180 degrees, due to the round trip through the 90-degree path difference. Thus the reflected waves cancel at both the transmitter port and at the receiver port (maintaining the isolation of the receiver). But each reflection also sends half of its power into Port 5. These voltages are in phase, so the total power arriving at Port 5 is equal to half the transmitter power.

In summary, the installation of the shorts on the sidearms has transformed the 6-port turnstile into a 4-port diplexer.



### 21.3 Length of the turnstile side shorts

So far, the only requirement placed on the side shorts is that their electrical lengths differ by 90 degrees. But, for the device to act as a “self diplexer”, the output wave must have circular polarization, i.e. the phase of the wave leaving Port 5 must differ by 90 degrees from the wave leaving Port 6. This is the same as saying that the wave entering Port 3, after being reflected from the side short at that port, differ in phase by 90 (or 270) degrees from the phase incident on Port 2, the transmitter port. If we know the the phase path, in degrees, between the transmitter port and an adjacent side port (i.e. the phase path between any two adjacent side ports), we can calculate the absolute lengths for the shorts. This phase path can be measured directly with a network analyzer or calculated using a finite element modeling program. If we do not know this phase path, we can fit the turnstile with adjustable shorts. The adjustment procedure would be first to set one short at an arbitrary position, say fully in, and set the other short farther out by  $\lambda_{\text{guide}}/4$ . We can verify that the separation is correct by noting that feed through to the receiver port is minimized. Next we vary the positions of the shorts, while maintaining the  $\lambda_{\text{guide}}/4$  difference, to circularize the polarization leaving the circular waveguide. One way to do this is to put a metal cap over the circular waveguide. The cap provides a totally reflecting short which will change the sense of the circular polarization, causing the reflection to leave via the receiver port. If we put a matched load on the receiver port, we simply adjust the shorts until there is no reflection seen at the transmitter port.

21.4 Sense of the polarization: right-hand circular or left-hand circular? The turnstile pictured below, produces left-circular polarization. After reflections from the tertiary, secondary, and primary mirrors, the radiated polarization is right-circular.

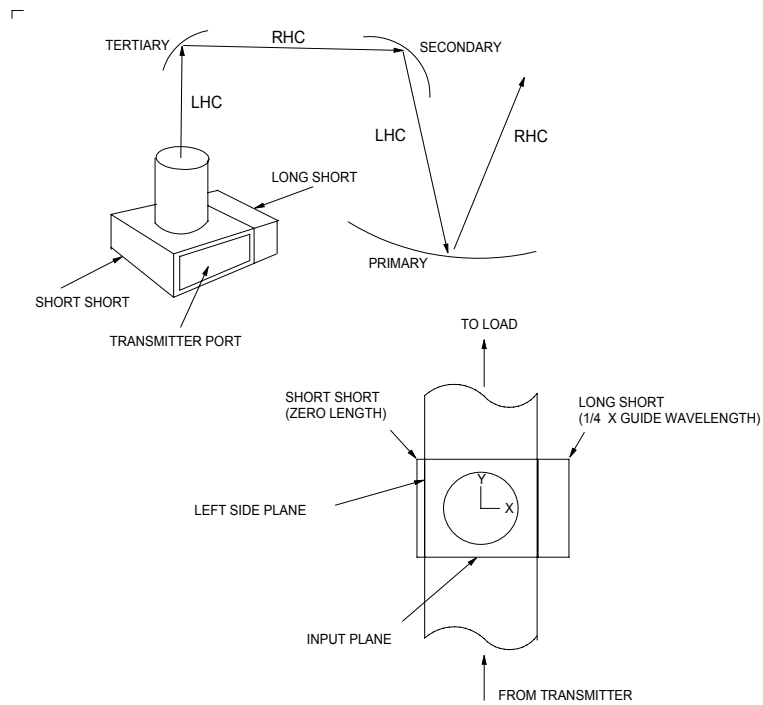

TURNSTILE, AS VIEWED LOOKING INTO THE CIRCULAR PORT.

FILE: cirpol.ecw

We consider the polarization of the wave coming out of the turnstile. We will take the phase of the y-component to be the phase at the input plane. In our S-band turnstile, the phase path from the input plane to the left side plane is almost exactly 270 degrees, as shown by lab measurements and by HFSS simulation. The wave making this left turn is then shifted another 180 degrees when it reflects from the short. The total phase of the x-component is therefore 270+180 = 90 degrees. Expressing the x and y components, we have

$$E_x = \text{Re}(e^{j\omega t - \pi/2}) = \cos(\omega t - \pi/2) = \sin(\omega t)$$

$$E_y = \text{Re}(e^{j\omega t}) = \cos(\omega t)$$

The E vector, as seen when the wave is *approaching* us, thus rotates in the *clockwise* direction. (As t increases from zero,  $E_x$  goes from zero to a positive number while  $E_y$  begins to decrease). By definition (IRE, IEEE) this is *left-circular* polarization. The tertiary, secondary, and primary reflectors each reverse the polarization so the telescope finally transmits *right-circular* polarization.



Dome turnstile junction. Side ports are half-height waveguide. Side shorts are fixed. Note concentric post tuning structure.

## **22. Safety and protection systems.**

Section 22.1 discusses personnel safety. Section 22.2 discusses the circuitry to protect the transmitter itself.

### **22.1.1 Personnel Safety systems & hazards: high-voltage, radiation, X-ray, Chemical**

With its high-voltage, high-power, and high places, this transmitter is potentially lethal.

Appropriate precautions must be taken to avoid electrical shock and radiation exposure - both RF and X-ray. Chemical hazards are less likely; the original PCB capacitors have been replaced by non-PCB capacitors, and the oil in the modulator tank has always been mineral oil. Nevertheless, this oil, (Texaco codigo 1515 transformer oil) runs at a high temperature, over 120 F, and with the very large exposed surface, gives off enough vapor to cause uncomfortable lung irritation. No beryllium oxide ceramics are used in the klystrons or other tubes, but, in any event, these tubes are never opened and even accidental breakage would not likely produce any beryllium oxide dust.

### **22.1.2 High voltage vault**

The high-voltage vault contains the 100,000-volt dc power supply, the capacitor bank, the modulator, the crowbar and crowbar trigger generator, and other associated transformers and switch gear. Except for a roll-up door to the outside, which can only be opened from the inside, there is only one entrance to the high-voltage vault. This entry door has a small window which provides a view of the obviously hazardous high-voltage equipment. The key that opens this door is the same key (attached to a large metal tag) that must be inserted in the lock switch on the console to operate the transmitter. Interlock circuitry allows the transmitter to operate only when the vault door is tightly closed and the tagged key is installed in the console. While the door is open, the tagged key cannot be removed from the door lock. The door lock actually has two keys, side by side. Both keys are needed to lock the door. When an engineer or technician is working in the vault, he may want to keep the second (untagged) key in his pocket to prevent anyone from accidentally locking him inside the vault and turning on the transmitter.

### **22.1.3 Entering the high voltage vault**

As explained above, the transmitter will normally be off before the vault door is opened, simply because the key to open the door can only be removed from the console when the console switch is in the off position. Moreover, when the transmitter is off, metal bars in the high voltage vault drop down to maintain a short-circuit on the capacitor bank, eliminating the most obvious high-voltage hazard. Even without the shorting bars, the two bleeder resistor stacks across the capacitor banks will discharge it in a few minutes. Nevertheless, one must always assume that these protection devices may have failed. Therefore, upon opening the door, always grasp the insulated handle of the tethered shorting bar (shorting cane) and touch its hooked metal tip to Point #1, the metal corona ball at the top of the high-voltage metering tower (the tower nearest the door). No arc should result. Leave the cane hooked to the top coronal ball. Take the second (longer) shorting cane from the floor, proceed into the vault and touch the metal tip of the cane to Point #2, the high voltage bus (the tubular aluminum rail that runs around the capacitor bank). Again, no arc should result (note that the rail and the corona ball are part of the same aluminum structure). Touch this cane to the lower corona ring (Point #3) and the upper corona ring (Point #4). Leave this cane

hooked to the upper corona ring. Remember to unhook both shorting canes before exiting and locking the vault.

#### **22.1.4 Capacitor bank safety**

Each of the 248 capacitors is connected to the high voltage bus by a 1000-ohm, 100 watt resistor. When one of these resistors must be removed for cleaning or replacement, it should be assumed that the resistor may have become an open circuit, leaving the capacitor charged and dangerous. Therefore, before touching one of these resistors, touch the tip of one of the tethered shorting canes to the capacitor terminal. Remember also that a nominally discharged capacitor may, when disconnected, develop a hazardous voltage due to dielectric absorption. Therefore, before removing the resistor, connect a shorting wire from the capacitor terminal to the capacitor bank frame. Leave this wire in place until the resistor or its replacement has been reinstalled.

#### **22.1.5 Modulator safety**

The modulator is totally enclosed by its steel tank and presents no hazard until the tank-top doors are lifted open. When the modulator must be worked on, lift both doors. (The left-hand door is over the Buffer Deck and the right-hand door is over the Floating Deck).

When the oil level has been pumped down to reveal the decks, clip a jumper from ground (the tank) to the Buffer Deck chassis and another jumper from ground to the Floating Deck Chassis. Keep a grounding cane ready ground any point that will be touched in the course of changing or adjusting a component. Touch the grounding cane to every exposed point, especially if you will be climbing into the tank. Also, before entering the tank, turn off the transmitter's main power switch (large brown box on the wall outside the vault) to be doubly sure that the ac prime power is not present. Remember that both decks contain numerous capacitors. Every capacitor is supposed to have a bleeder resistor. Nevertheless, bleeders might be open or even missing. If touching the grounding cane to any point draws a spark, use the schematic diagrams to determine which capacitor still had charge and replace the corresponding bleeder. The characteristics and safety information for the Texaco 1515 transformer oil is attached to the end of this section.

#### **22.1.6 Crowbar safety**

The crowbar circuit produces a high-voltage pulse on the sharp probe between the two discharge balls. When the transmitter is off, a high-voltage vacuum relay grounds the plate of the 5C22 Thyatron tube, used to produce this pulse. Nevertheless, before working on the crowbar circuit, use grounding canes and jumpers to ensure that no capacitors remain charged.

#### **22.1.7 X-ray hazards**

Because the high-voltage supply produces up to 120,000 volts, X-rays can be produced in by the klystrons. For this reason, the klystron vault is shielded with slabs of lead. Still, measurements have shown that some radiation is present outside the vault at the top and bottom ends of the tubes. Radiation hazard warning stickers are placed on the klystron vault near the door of the high-voltage vault and on the mezzanine, near the top of the klystron vault. Stay clear of these areas when the transmitter is in operation.

### 22.1.8 RF radiation hazards

No hazardous RF radiation levels should exist near the transmitter. All the RF energy should be confined inside the klystrons and inside the waveguide transmission line. Of course, periodic tests should be made with the NARDA radiation detector to be sure that none waveguide plumbing is leaking from cracks or loose flanges. When the line feed was the only transmitter feed, we allowed personnel to work on the platform, except around the top of the carriage house near the collector, where the excessive RF fields were measured. Now, with the dual beam system (transmission possible from both the carriage house and the dome), **personnel are not allowed on the platform while the transmitter is in use, no matter whether the dome feed is in use or not.** There is considerable spill over from the horn in the dome, producing large fields inside and even above the dome. Even if all the power is being steered to the carriage house, the design of the power splitter allows large standing waves to build up in slotted waveguide nominally not in use, depending on the position of the dome. When bolt-in transmitter waveguide section is not installed in the dome, we take the precaution of bolting a plate over transmitter end of the gap. Note that the waveguide run between the splitter and this plate will act as a high Q resonant cavity if its electrical length, as determined by the position of the dome along the elevation rail, is an odd number of quarter wavelengths. In this case, even with the splitter set for the carriage house, a large standing wave can be present in the this line. Workers near the slotted part of the line could be exposed to excessive radiation. This is one of the reasons that personnel must be off the platform, no matter the mode of operation.

## 22.2 Transmitter Protection Systems

### 22.2.1 Arc Detectors (See Section 12.2)

### 22.2.2 Reflected Power Alarm (See section 12.2)

The Reflected Power Alarm is misnamed, in that its primary function is to remove the klystron RF drive as soon as excessive reflected power is sensed at the output of either klystron. A second TTL signal (normally low) is provided to actuate an audible alarm..

Refer to the schematic diagram “Reflected Power and Arc Alarm Shut-off”. Reflected power is sensed by 50 dB directional couplers at the output of each klystron. These signals are further attenuated by a 2 dB pads and also by cable loss between the mezzanine and the console. Diode detectors in the console provide dc signals for the two sensing circuits in the console-mounted Reflected Power and Arc Alarm Shut-off chassis. These circuits are straightforward: the detected signal, a negative voltage, feeds current into the summing point of a conventional inverting op amp. A local positive bucking current is adjusted so that the output of the op amp remains negative unless the reflected power increases. BNC monitor ports are provided so that the operator can see how closely the op amp outputs approach zero. Comparators follow the op amps; any positive excursion triggers a comparator and latches a flip-flop. The flip-flops for the two comparators are ORed to form the output signal. A front panel push button is provided to reset the flip-flops. A “Test” button is provided to inject a signal equivalent to a -3V signal from the detectors (roughly the signal expected when the reflected power is 15 dB below 1MW of forward power).

### 22.2.3 Crowbar

The Crowbar circuit is described in Section 12. Note that this circuit, by itself, can be lethal. Use appropriate care when servicing it; use temporary jumpers across high voltage capacitors.

22.2.4

MSDS for the Texaco 1515 mineral oil used in the modulator tank

## Material Safety Data Sheet

### 24-Hour Emergency Telephone Numbers

HEALTH : ChevronTexaco Emergency Information Center (800) 231-0623 or (510) 231-0623

TRANSPORTATION : CHEMTREC (800) 424-9300 or (703) 527-3887

Emergency Information Centers are located in the U.S.A. International collect calls accepted.

## SECTION 1 PRODUCT AND COMPANY IDENTIFICATION

### TEXACO Transformer Oils

**Product Number(s):** 00600, 01515, CPS220600, CPS221515

**Synonyms:** TEXACO Transformer Oil, TEXACO Transformer Oil Inhibited

#### Company Identification

ChevronTexaco Global Lubricants  
6001 Bollinger Canyon Road  
San Ramon, CA 94583  
United States of America

#### Product Information

Product Information: 800-LUBE-TEK  
email : lubemsds@chevron.com

## SECTION 2 COMPOSITION/ INFORMATION ON INGREDIENTS

COMPONENTS	CAS NUMBER	AMOUNT
Distillates, hydrotreated light naphthenic	64742-53-6	40 - 60 %weight
Distillates, hydrotreated middle	64742-46-7	40 - 60 %weight

## SECTION 3 HAZARDS IDENTIFICATION

### IMMEDIATE HEALTH EFFECTS

**Eye:** Not expected to cause prolonged or significant eye irritation.

**Skin:** Contact with the skin is not expected to cause prolonged or significant irritation. Contact with the skin is not expected to cause an allergic skin response. Not expected to be harmful to internal organs if absorbed through the skin.

**Ingestion:** Not expected to be harmful if swallowed.

**Inhalation:** Not expected to be harmful if inhaled. Contains a petroleum-based mineral oil. May cause respiratory irritation or other pulmonary effects following prolonged or repeated inhalation of oil mist at airborne levels above the recommended mineral oil mist exposure limit. Symptoms of respiratory irritation may include coughing and difficulty breathing.

#### SECTION 4 FIRST AID MEASURES

**Eye:** No specific first aid measures are required. As a precaution, remove contact lenses, if worn, and flush eyes with water.

**Skin:** No specific first aid measures are required. As a precaution, remove clothing and shoes if contaminated. To remove the material from skin, use soap and water. Discard contaminated clothing and shoes or thoroughly clean before reuse.

**Ingestion:** No specific first aid measures are required. Do not induce vomiting. As a precaution, get medical advice.

**Inhalation:** No specific first aid measures are required. If exposed to excessive levels of material in the air, move the exposed person to fresh air. Get medical attention if coughing or respiratory discomfort occurs.

#### SECTION 5 FIRE FIGHTING MEASURES

##### FIRE CLASSIFICATION:

OSHA Classification (29 CFR 1910.1200): Not classified by OSHA as flammable or combustible.

**NFPA RATINGS:** Health: 0 Flammability: 1 Reactivity: 0

##### FLAMMABLE PROPERTIES:

**Flashpoint:** (Cleveland Open Cup) 295 °F (146 °C) (Min)

**Autoignition:** NDA

**Flammability (Explosive) Limits (% by volume in air):** Lower: NDA Upper: NDA

**EXTINGUISHING MEDIA:** Use water fog, foam, dry chemical or carbon dioxide (CO<sub>2</sub>) to extinguish flames.

##### PROTECTION OF FIRE FIGHTERS:

**Fire Fighting Instructions:** This material will burn although it is not easily ignited. For fires involving this material, do not enter any enclosed or confined fire space without proper protective equipment, including self-contained breathing apparatus.

**Combustion Products:** Highly dependent on combustion conditions. A complex mixture of airborne solids, liquids, and gases including carbon monoxide, carbon dioxide, and unidentified organic compounds will be evolved when this material undergoes combustion.

#### SECTION 6 ACCIDENTAL RELEASE MEASURES

**Protective Measures:** Eliminate all sources of ignition in vicinity of spilled material.

**Spill Management:** Stop the source of the release if you can do it without risk. Contain release to prevent further contamination of soil, surface water or groundwater. Clean up spill as soon as possible, observing



precautions in Exposure Controls/Personal Protection. Use appropriate techniques such as applying non-combustible absorbent materials or pumping. Where feasible and appropriate, remove contaminated soil. Place contaminated materials in disposable containers and dispose of in a manner consistent with applicable regulations.

**Reporting:** Report spills to local authorities and/or the U.S. Coast Guard's National Response Center at (800) 424-8802 as appropriate or required.

## SECTION 7 HANDLING AND STORAGE

**General Handling Information:** Avoid contaminating soil or releasing this material into sewage and drainage systems and bodies of water.

**Static Hazard:** Electrostatic charge may accumulate and create a hazardous condition when handling this material. To minimize this hazard, bonding and grounding may be necessary but may not, by themselves, be sufficient. Review all operations which have the potential of generating an accumulation of electrostatic charge and/or a flammable atmosphere (including tank and container filling, splash filling, tank cleaning, sampling, gauging, switch loading, filtering, mixing, agitation, and vacuum truck operations) and use appropriate mitigating procedures. For more information, refer to OSHA Standard 29 CFR 1910.106, 'Flammable and Combustible Liquids', National Fire Protection Association (NFPA 77, 'Recommended Practice on Static Electricity', and/or the American Petroleum Institute (API) Recommended Practice 2003, 'Protection Against Ignitions Arising Out of Static, Lightning, and Stray Currents'.

**Container Warnings:** Container is not designed to contain pressure. Do not use pressure to empty container or it may rupture with explosive force. Empty containers retain product residue (solid, liquid, and/or vapor) and can be dangerous. Do not pressurize, cut, weld, braze, solder, drill, grind, or expose such containers to heat, flame, sparks, static electricity, or other sources of ignition. They may explode and cause injury or death. Empty containers should be completely drained, properly closed, and promptly returned to a drum reconditioner or disposed of properly.

## SECTION 8 EXPOSURE CONTROLS/PERSONAL PROTECTION

### GENERAL CONSIDERATIONS:

Consider the potential hazards of this material (see Section 3), applicable exposure limits, job activities, and other substances in the work place when designing engineering controls and selecting personal protective equipment. If engineering controls or work practices are not adequate to prevent exposure to harmful levels of this material, the personal protective equipment listed below is recommended. The user should read and understand all instructions and limitations supplied with the equipment since protection is usually provided for a limited time or under certain circumstances.

### ENGINEERING CONTROLS:

Use in a well-ventilated area.

### PERSONAL PROTECTIVE EQUIPMENT

**Eye/Face Protection:** No special eye protection is normally required. Where splashing is possible, wear safety glasses with side shields as a good safety practice.

**Skin Protection:** No special protective clothing is normally required. Where splashing is possible, select protective clothing depending on operations conducted, physical requirements and other substances in the workplace. Suggested materials for protective gloves include: Nitrile Rubber, Viton.

**Respiratory Protection:** No respiratory protection is normally required.

If user operations generate an oil mist, determine if airborne concentrations are below the occupational exposure

limit for mineral oil mist. If not, wear an approved respirator that provides adequate protection from the measured concentrations of this material. For air-purifying respirators use a particulate cartridge. Use a positive pressure air-supplying respirator in circumstances where air-purifying respirators may not provide adequate protection.

**Occupational Exposure Limits:**

Component	Limit	TWA	STEL	Ceiling	Notation
Distillates, hydrotreated naphthenic	light OSHA PEL	5 mg/m3			
Distillates, hydrotreated naphthenic	light ACGIH TLV	5 mg/m3	10 mg/m3		
Distillates, hydrotreated naphthenic	light ACGIH	5 mg/m3	10 mg/m3		

**SECTION 9 PHYSICAL AND CHEMICAL PROPERTIES**

Attention: the data below are typical values and do not constitute a specification.

**Color:** Colorless

**Physical State:** Liquid

**Odor:** Petroleum odor

**pH:** NA

**Vapor Pressure:** NDA

**Vapor Density (Air = 1):** >1

**Boiling Point:** >392 F (>200 °C)

**Solubility:** Soluble in hydrocarbons; insoluble in water

**Freezing Point:** NA

**Melting Point:** NDA

**Specific Gravity:** 0.88 @ 15.6 °C / 15.6 °C

**Viscosity:** 8.8 cSt @ 40 °C (Typical)

**Evaporation Rate:**

**SECTION 10 STABILITY AND REACTIVITY**

**Chemical Stability:** This material is considered stable under normal ambient and anticipated storage and handling conditions of temperature and pressure.

**Incompatibility With Other Materials:** May react with strong oxidizing agents, such as chlorates, nitrates, peroxides, etc.

**Hazardous Decomposition Products:** None known (None expected)

**Hazardous Polymerization:** Hazardous polymerization will not occur.

## SECTION 11 TOXICOLOGICAL INFORMATION

### IMMEDIATE HEALTH EFFECTS

**Eye Irritation:** The eye irritation hazard is based on evaluation of data for similar materials or product components.

**Skin Irritation:** The skin irritation hazard is based on evaluation of data for similar materials or product components.

**Skin Sensitization:** The skin sensitization hazard is based on evaluation of data for similar materials or product components.

**Acute Dermal Toxicity:** The acute dermal toxicity hazard is based on evaluation of data for similar materials or product components.

**Acute Oral Toxicity:** The acute oral toxicity hazard is based on evaluation of data for similar materials or product components.

**Acute Inhalation Toxicity:** The acute inhalation toxicity hazard is based on evaluation of data for similar materials or product components.

### ADDITIONAL TOXICOLOGY INFORMATION:

This product contains petroleum base oils which may be refined by various processes including severe solvent extraction, severe hydrocracking, or severe hydrotreating. None of the oils requires a cancer warning under the OSHA Hazard Communication Standard (29 CFR 1910.1200). These oils have not been listed in the National Toxicology Program (NTP) Annual Report nor have they been classified by the International Agency for Research on Cancer (IARC) as; carcinogenic to humans (Group 1), probably carcinogenic to humans (Group 2A), or possibly carcinogenic to humans (Group 2B).

## SECTION 12 ECOLOGICAL INFORMATION

### ECOTOXICITY

The toxicity of this material to aquatic organisms has not been evaluated. Consequently, this material should be kept out of sewage and drainage systems and all bodies of water.

### ENVIRONMENTAL FATE

This material is not expected to be readily biodegradable.

## SECTION 13 DISPOSAL CONSIDERATIONS

Oil collection services are available for used oil recycling or disposal. Place contaminated materials in containers and dispose of in a manner consistent with applicable regulations. Contact your sales representative or local environmental or health authorities for approved disposal or recycling methods.

## SECTION 14 TRANSPORT INFORMATION

The description shown may not apply to all shipping situations. Consult 49CFR, or appropriate Dangerous Goods Regulations, for additional description requirements (e.g., technical name) and mode-specific or quantity-

specific shipping requirements.

**DOT Shipping Name:** NOT REGULATED AS A HAZARDOUS MATERIAL FOR TRANSPORTATION UNDER 49 CFR

**DOT Hazard Class:** NOT APPLICABLE

**DOT Identification Number:** NOT APPLICABLE

**DOT Packing Group:** NOT APPLICABLE

**Additional Information:** NOT HAZARDOUS BY U.S. DOT. ADR/RID HAZARD CLASS NOT APPLICABLE.

## SECTION 15 REGULATORY INFORMATION

**SARA 311/312 CATEGORIES:**

1. Immediate (Acute) Health Effects:	NO
2. Delayed (Chronic) Health Effects:	NO
3. Fire Hazard:	NO
4. Sudden Release of Pressure Hazard:	NO
5. Reactivity Hazard:	NO

### REGULATORY LISTS SEARCHED:

4_I1=IARC Group 1	15=SARA Section 313
4_I2A=IARC Group 2A	16=CA Proposition 65
4_I2B=IARC Group 2B	17=MA RTK
05=NTP Carcinogen	18=NJ RTK
06=OSHA Carcinogen	19=DOT Marine Pollutant
09=TSCA 12(b)	20=PA RTK

No components of this material were found on the regulatory lists above.

### CHEMICAL INVENTORIES:

AUSTRALIA: All the components of this material are listed on the Australian Inventory of Chemical Substances (AICS).

CANADA: All the components of this material are on the Canadian DSL or have been notified under the New Substance Notification Regulations, but have not yet been published in the Canada Gazette.

PEOPLE'S REPUBLIC OF CHINA: All the components of this product are listed on the draft Inventory of Existing Chemical Substances in China.

EUROPEAN UNION: All the components of this material are in compliance with the EU Seventh Amendment Directive 92/32/EEC.

JAPAN: All the components of this product are on the Existing & New Chemical Substances (ENCS) inventory in Japan, or have an exemption from listing.

KOREA: All the components of this product are on the Existing Chemicals List (ECL) in Korea.

PHILIPPINES: All the components of this product are listed on the Philippine Inventory of Chemicals and Chemical Substances (PICCS).

UNITED STATES: All of the components of this material are on the Toxic Substances Control Act (TSCA) Chemical Inventory.

**NEW JERSEY RTK CLASSIFICATION:**

Under the New Jersey Right-to-Know Act L. 1983 Chapter 315 N.J.S.A. 34:5A-1 et. seq., the product is to be identified as follows:

PETROLEUM OIL (Lubricating oil)

**WHMIS CLASSIFICATION:**

This product is not considered a controlled product according to the criteria of the Canadian Controlled Products Regulations.

**SECTION 16 OTHER INFORMATION**

**NFPA RATINGS:** Health: 0 Flammability: 1 Reactivity: 0

**HMIS RATINGS:** Health: 0 Flammability: 1 Reactivity: 0

(0-Least, 1-Slight, 2-Moderate, 3-High, 4-Extreme, PPE:- Personal Protection Equipment Index recommendation, \*- Chronic Effect Indicator). These values are obtained using the guidelines or published evaluations prepared by the National Fire Protection Association (NFPA) or the National Paint and Coating Association (for HMIS ratings).

**REVISION STATEMENT:** This is a new Material Safety Data Sheet.

ABBREVIATIONS THAT MAY HAVE BEEN USED IN THIS DOCUMENT:

- |      |   |                           |     |   |                                  |
|------|---|---------------------------|-----|---|----------------------------------|
| TLV  | - | Threshold Limit Value     | TWA | - | Time Weighted Average            |
| STEL | - | Short-term Exposure Limit | PEL | - | Permissible Exposure Limit       |
|      |   |                           | CAS | - | Chemical Abstract Service Number |
| NDA  | - | No Data Available         | NA  | - | Not Applicable                   |
| <=   | - | Less Than or Equal To     | >=  | - | Greater Than or Equal To         |

Prepared according to the OSHA Hazard Communication Standard (29 CFR 1910.1200) and the ANSI MSDS Standard (Z400.1) by the ChevronTexaco Energy Research & Technology Company,

100 Chevron Way, Richmond, California 94802.

## 22.4.5

**Testing the modulator oil for voltage breakdown: from**  
**<http://www.nttworldwide.com/tech2208.htm>**

### Dielectric Breakdown Voltage

#### Background:

The dielectric breakdown voltage is a measure of an insulating fluids ability to withstand a high electric field stress without breaking down. It can also indicate the presence of water or other contaminants in the oil; however, a high dielectric breakdown voltage does not necessarily prove the absence of contaminants. The dielectric breakdown voltage is not a constant of the material being tested like the dielectric constant but it is a statistical process and as a result repetitive determinations have to be done. The results can also be dependent on the design of the electrodes, the spacing of the electrodes, the wave form of the applied voltage, and the rate of rise of the applied voltage. There are two methods recognized by ASTM for this method. The first method uses disk electrodes with a voltage ramp of 3000 V/s (ASTM D 877) and the second method uses spherical electrodes with a voltage ramp of 500 V/s (ASTM D 1816).

#### Procedure:

The details of the entire procedures for determining the dielectric breakdown voltage of oil using disk electrodes are given in the ASTM D 877 standard and for the spherical electrodes in the ASTM D 1816 standard and both are only briefly mentioned here.

The disk electrode system utilizes 25 mm diameter square-edged disks separated by 2.5 mm. The cell is filled with oil to cover the electrodes to at least a depth of 20 mm and the sample is allowed to set for at least 2 minutes without agitation. A 60 Hz sinusoidal wave voltage is applied at a ramp rate of 3000 V/s until breakdown occurs as indicated by passage of a current through the sample of 2 to 20 mA. This occurrence is used to trip a relay within 3 to 5 cycles that stops the voltage ramping and maintaining the breakdown voltage. A series of determinations are done, which are then treated statistically to yield the final value.

The spherical electrode system utilizes electrodes that have a 25 mm radius and are spaced either 1 or 2 mm apart. The cell should be filled with enough oil to cover the top of the electrodes with at least 13 mm of oil. The cell shall be equipped with a propeller to circulate the oil in a downward direction during the testing procedure. A 60 Hz sinusoidal wave voltage is applied at a ramp rate of 500 V/s until breakdown occurs as indicated by a passage of current through the sample of 2 to 20 mA. This occurrence is used to trip a relay that stops the voltage ramping and maintains the value of the breakdown voltage. A series of determinations are done, which are then treated statistically to yield the final value.

#### Significance:

The more uniform electric field of the spherical electrode system makes this method more sensitive to the presence of water or other conducting particulate material in the fluid. It is for this reason that the oil must be circulated during the measurement to insure that any particles are uniformly suspended in the oil. The two different ASTM methods have different purposes and should be used accordingly. The ASTM D 1816 method is recommended for testing filtered, degassed, and dehydrated oil prior to and during the filling of power systems rated above 230 kV and for testing of samples from units that are in service. This method should not be used for acceptance testing of insulating fluids. The ASTM D 877 method should be used for acceptance testing and it should not be used for units in service.

The IEEE has suggested guidelines for dielectric breakdown voltages depending on the type of oil and unit it is being used in (IEEE C57.106-1991). Some representative values are given below:

Type of Oil/Unit	Dielectric Breakdown Voltage		
	D-877	D-1816 1mm gap	D-1816 2mm gap
Shipment of New Oil from Refinery	30 kV min.	Not Spec.	Not Spec.
New Oil Received in New Equipment			
< or = 69 kV	30 kV min.2	20 kV min.	40 kV min
69 - 288 kV	30 kV min.	30 kV min.	48 kV min.
> 345 kV	30 kV min.	30kVmin	60kVmin

New Oil for Circuit Breakers

	30 kV min.	Not Spec.	Not Spec.
--	------------	-----------	-----------

Suggested Limits for Oil used

in Circuit Breakers	25 kV min	Not Spec.	Not Spec.
---------------------	-----------	-----------	-----------

Copyright © 1996-1998 NTT. All Rights Reserved.



## **23. Maintenance**

### **20.1 Modulator Tank**

The insulating oil should withstand 28Kv per 1/10" or better. Check level in cathode well.

### **20.2 Klystron Replacement Procedure**

This section copied from a memo written by Engineer Domingo Albino. Refer also to the L-3403 Litton Klystron "Installation and Operation Manual".

Klystron Replacement Procedure

#### **1 Equipment Disassembly**

- 1.1 Turn off Vac-ion pumps at console (Varian Pump Control Unit)
- 1.3 Turn off main 4160 Switch (brown box on the IPA side of the wall between the IPA and HV vault.
- 1.4 Start draining water from cooling system. Water can be drained by disconnecting the hose from the 250 gallon tank and opening the drain valve located at the main pump. In case there is not enough distilled water in the tank, the system can be drained into the 250 gallon tank. The water is drained to a level where there are no spills from the klystron hoses.
- 1.5 Check the oil tanks for water condensation by opening the valve located at the bottom of each tank and letting the liquid run out until oil comes out. Close the valve.
- 1.6 Inspect oil processing system. Clean if necessary.
- 1.7 Open valves at klystron oil tank and along the oil pipe as needed to open a path through the pump and into one of the oil tanks. make sure that the return valves at the bottom of the tanks are close.
- 1.8 Start the oil pump. Listen for oil going into the selected tank. In about two hours the oil will be drained.
- 1.9 By this time outside help from the maintenance group should have arrived to start undoing the waveguide installation on top of the klystron tank.

#### **2. Disassembly of the waveguide**

- 2.1 Disconnect the RF and control cables going to the waveguide transformer. Save screws and RF parts for reuse.
- 2.2 Unbolt the corrugated sections at their flanges. Use hand tools; vibration from power tools could break the ceramic output window of the klystron. The corrugated pieces can be stored on the mezzanine.
- 2.3 Unbolt the RF transformer section. Save the hardware for reuse. Store the transformer out of the way.
- 2.4 Use the crane and sling to hold the lead plate in front of the klystron enclosure. Unbolt the plate from inside the cabinet and lower it to the floor CAREFULLY.
- 2.5 Remove top hat box and place it on the floor.

#### **3. Klystron disassembly**

- 3.1 Make sure Vac-ion power supplies are OFF. Disconnect the high voltage plug for the vac-ion pumps at the klystrons.
- 3.2 Disconnect air hoses coming from the fan turbines at the klystron end.

- 3.3 Unbolt and remove the rings in the front side of the waveguide transition. Unbolt and remove the half ring at the rear side of the RF transition. Save all hardware.
- 3.4 Remove front RF gasket and save for reuse.
- 3.5 Disconnect air duct from RF transition by unstrapping vibration damping tape.
- 3.6 Make sure all RF cables and RF [parts such as attenuators, loads, and DC blocks have been removed and saved for reuse. The RF transition must be ready to be pulled out. Double check for overlooked connections or loose bolts and nuts. RF input cable coming in at floor level must be disconnected.
- 3.7 Pull out RF transition, CAREFULLY. Do not rub it against the klystron's ceramic window.
- 3.8 Check for water level. If already below the hose connection elevation, pull out cooling water hoses at klystron end. (5 hoses)
- 3.9 Pull out vac-ion pump connector.
- 3.10 Disconnect RG17 cable which connects to collector.

#### 4. **Motors**

- 4.1 Loosen the micro switch actuating ring.
- 4.2 Rotate the sprocket wheel CCW until it hits the end.
- 4.3 Unscrew the two bolts holding the motor to the klystron body.
- 4.4 Rotate the motor ccw until it comes out completely.

Note: the following instructions apply to motors 1,2, and 3, counting from the bottom up.

- 4.5 Disconnect control cables. AC power must be off.
- 4.6 Open the front drive chain at the break link. Put it aside, saving all hardware.
- 4.7 Loosen the micro switch actuator ring.
- 4.8 Unscrew the two bolts holding the motor to the klystron body.
- 4.9 Rotate the motor clockwise just enough to allow lessening a socket head screw in the plate base of the motor.
- 4.10 Rotate the sprocket wheel CCW to take the motor out. Then unscrew the plunger drive out.
- 4.11 Save the chain and motor pair together. They form different sets: do not mix.

#### 5 **Instructions for motor No. 4**

- 5.1 Disconnect the control cables.
- 5.2 Open the drive chain at the break link and save all hardware.
- 5.3 turn motor and mount until they come out completely from the cavity socket.

Note: Check oil level. If it has run down to where the pump starts sucking air, stop it. There is a stop switch near the door inside the high voltage vault. If the oil needs reprocessing it can be started now by recirculating it in the same tank.

#### 6. **Klystron pull out**

- 6.1 Connect the lifting sling and crane to the eye bolts on the klystron flange. Lift vertically, taking care that the ceramic window does not contact anything. Watch for the magnet and keep it from hitting the roof of the cabinet. Observe the rings in the klystron body and don't let them bind against the magnet casing. When the tube is high enough to clear the

cabinet window, pull it out slowly and move it out observing as it goes along the coaxial line. Watch for air connection in the coaxial line. when the tube is out, away from the cabinet, position it on the rack at the mezzanine.

- 6.2 Disconnect the sling and attach it to the replacement klystron.
  - 6.3 Insert the new tube into the magnet assembly and socket; be careful of ceramic, magnet, and body rings. Rotate tube to position it so that tuners align with motor mounting holes in magnet casing.  
Hint: Test mount motor #4 to check alignment. Mount motor and base by turning motor mount until the push rod shaft screws into cavity socket. Motor can be left attached to klystron.
  - 6.4 Inside oil tank, connect a voltmeter in parallel with the klystron filament. See Fig. 1
  - 6.5 Break the cable connection at the filament transformer and connect an ammeter in series with the filament. This meter should be of the shielded movement type such as the Weston Model 904. Use a blower (500 CFM available) to cool the klystron cathode ceramic while doing the filament test.
  - 6.6 Filament voltage and current must then be adjusted to match the manufacturer's specifications.
  - 6.7 Let the klystron warm up for about 20minutes and readjust for specified voltage and current.
  - 6.8 Turn off filaments, take out the meters, and reconnect the filament.
  - 6.9 Connect hoses to klystron and start refilling the water system. Check for leaks. have rags at hand for any spills. Do no let water enter the oil tank! Circulate the water to make sure there are NO leaks in the system.
  - 6.10 After fixing any water leaks, start re-assembly of the waveguide and output connections. When installing waveguide transition , make sure that its weight is not carried by the klystron output window. Shim it against the cabinet. Fill u klystron tank with oil. To do this, open the valves at the bottom pipe coming from the oil container, through the pump, and back tot he pipe going into the klystron tank. When the oil is above the switch tubes' upper connections, the power can be turned on at the modulator to heat up and displace any air trapped in the oil. As soon as the pump starts pushing air through, stop the pump and close all vales. Now you are ready for aging the klystron
  - 6.11 Connect Vac-Ion pump high voltage connector and turn on the power supplies.
7. Aging resistor connection: See applicable instructions.
  8. Aging procedure: See applications instructions for HV aging, Pulse agin, RF aging and tuning procedure

## 9 **Motor Installation**

- 9.1 Instructions for motor No. 1,2, and 3
  - 9.1.1 Install the cavity push rod by screwing it into the cavity nut.
  - 9.1.2 Place the motor at the free end of the push rod. Mount the switch actuator ring on the rod, and insert the rod through the back opening in the motor mount. Now turn the sprocket wheel on the push rod until the motor mount hits the cavity mounting face.
  - 9.1.3 The push rod has a key way; position it in place with the key screw in the motor mount.
  - 9.1.4 Bolt the motor mount to the klystron body with two long screws.

- 9.1.5 Position the micro switch actuator to. activate the micro switches two turns before hitting the mechanical stops of the cavities in both directions.
- 9.1.6 Install the chain and connect the AC power cables.
- 9.2 Motor No. 4
- 9.2.1 This motor must be in place already. If it is out, place push rod shaft into the cavity socket and turn complete assembly 90 degrees (motor and mount) until the motor mount hits the klystron body. Hold with the available bolts to the klystron.
- 9.2.2 Be sure to adjust micro switch actuator ring to actuate the switches two turns before hitting the ends.
- 9.2.3 Install the drive chain and connect the AC power cables.

## 20.2 Klystron Aging and Tuning Procedures

This section copied from a memo written by Engineer. Domingo Albino.

See Figure below (temporary changes to power supply for tube aging).

- 1.1 Disconnect mod anode HV cable at the 75 KV bushing.
- 1.2 Remove the multiplier resistor at the 75 kV bushing. This bushing is located on the skirt of the oil tank, enclosed in a plexiglass box. Dress the wiring away from all grounded surfaces.
- 1.3 Connect a jumper between the 150 kV bushing (large brown bushing on top of the oil tank) and the floating deck. A strap with battery clips is available for this connection.
- 1.4 Remove the section of the protective nichrome fuse resistor on top of the capacitor bank.
- 1.5 Place the 15M, 200W resistor (in fiberglass casing) in place of the high voltage fuse resistor section. The 15M resistor can be found lying on a beam on top of the capacitor bank.
- 1.6,7 Disconnect J57, the body current cable and J56, the PW monitoring cable going to the crowbar. Both J56 and J57 are located at the skirt of the capacitor bank at the side looking toward the beam transformer.
- 1.8 At the half voltage point on top of the capacitor bank, remove the four 100 Ohm, 100 watt resistors (R84) and the four 100K, 200W resistors which form R52. These are located in an isolated rack on top of the capacitor bank.
- 1.9 Disconnect filter capacitor C87 (12uF 10kV).
- 1.10 Remove the round bar beneath R52.
- 1.11 Disconnect ground return to zener reference stack.
- 1.12 (No longer applicable)
- 1.13 Turn off the mod deck circuit breaker at the skirt of the klystron tank under the rat-race dummy load.
- 1.14 To age the klystron, turn on the HV and raise it slowly. If you are looking at the oscilloscope in the mod-anode position, you will notice sharp trace changes whenever an arc occurs inside the klystron. Stop at the voltage where arcing begins and then increase slowly in steps of about 2kV. Stop for a couple of minutes at each voltage level where an arc occurs, before continuing. Take the

voltage up to 115kV and leave it there for about 10 minutes. When no more arcs are detected, lower the voltage and restore the power supply connections to the normal operating configuration.

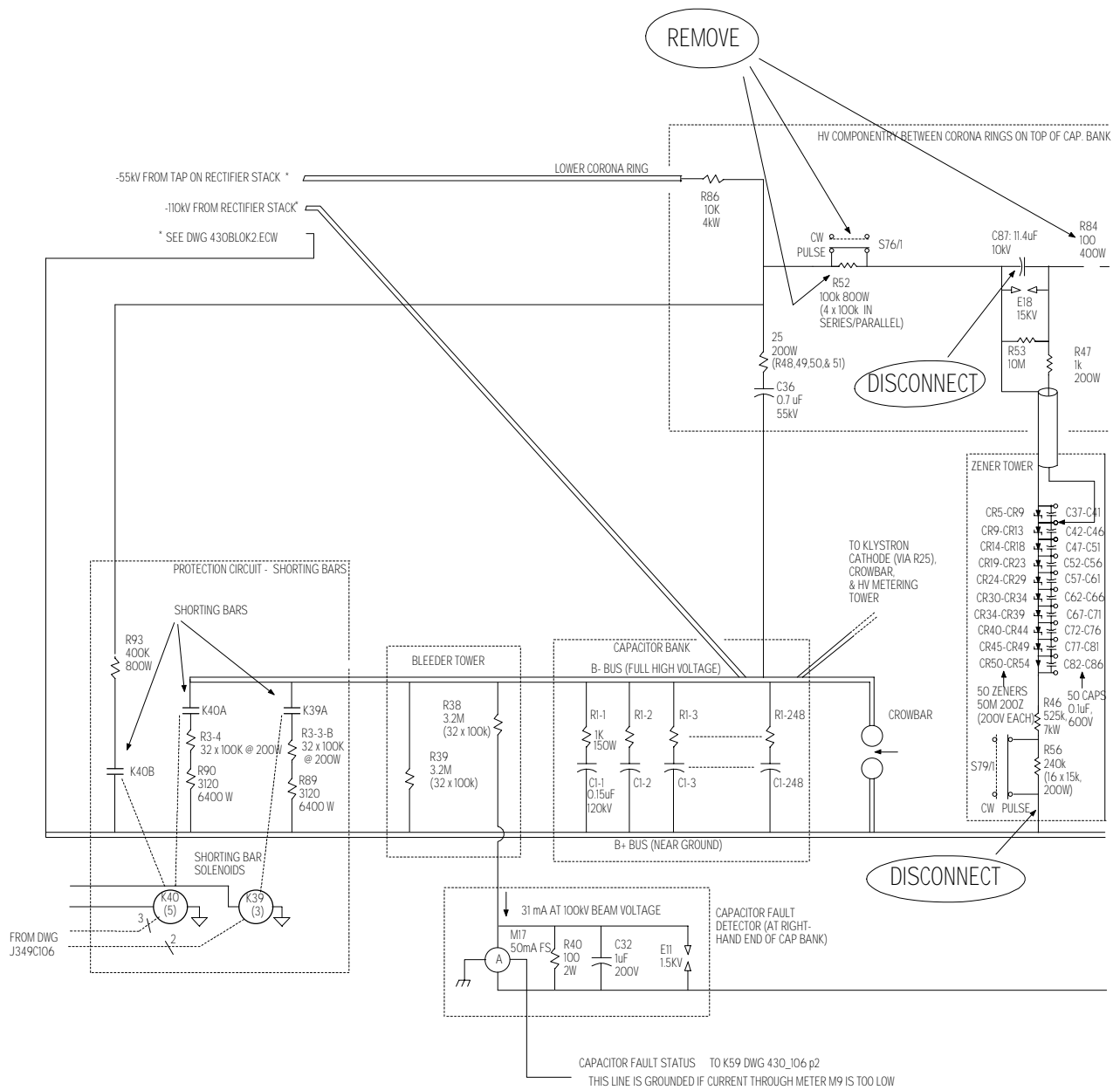

TURN OFF MODULATOR VIA BREAKER NEAR DOOR OF KLYSTRON VAULT

# KLYSTRON AGING SET-UP

## PAGE 1 OF 2

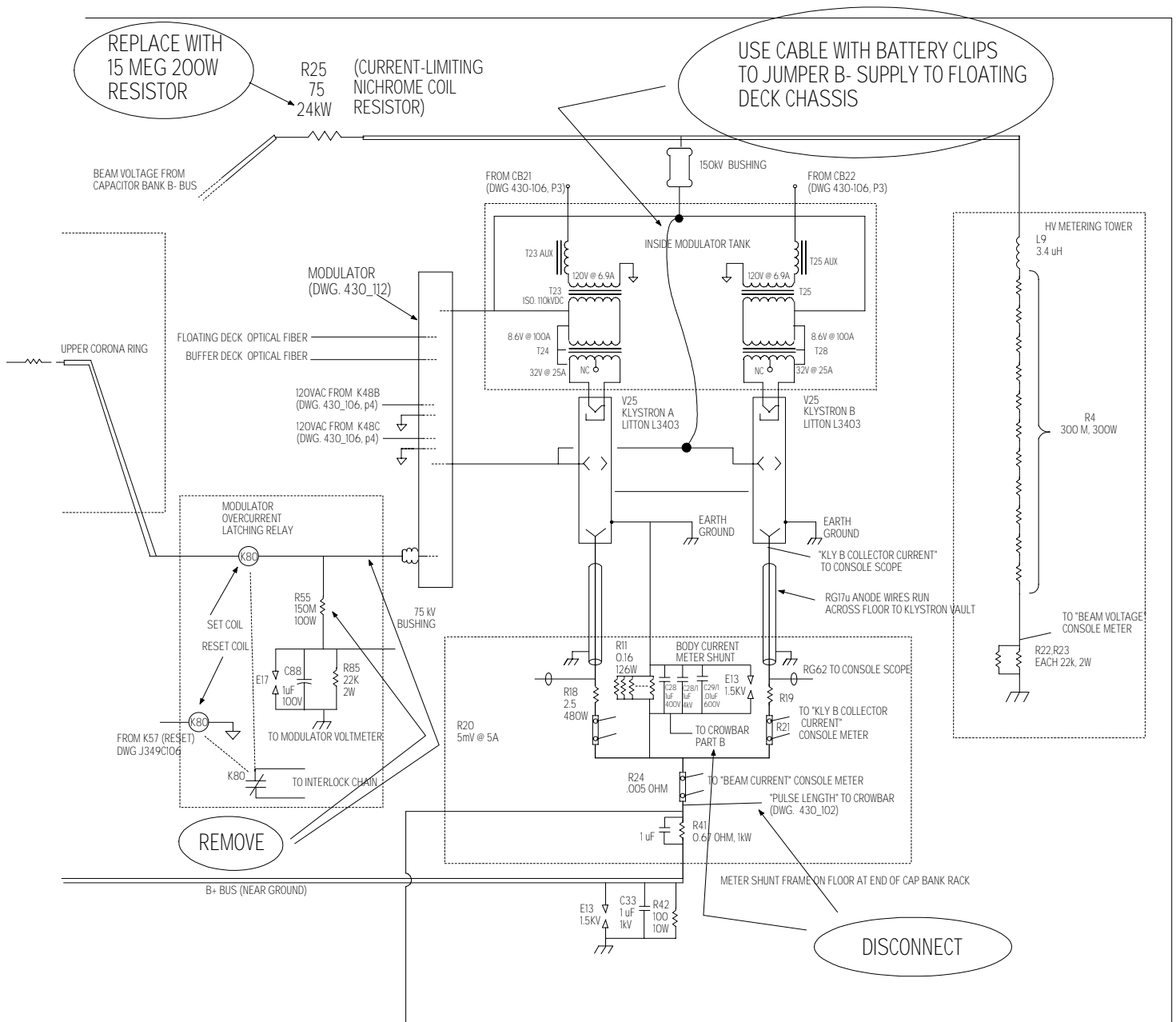

EARTH GROUND   
 AC COMMON 

# KLYSTRON AGING SET-UP

## PAGE 2 OF 2

430 TRANSMITTER  
 DWG. 430\_105.ecw 430\_AGE  
 TITLE: CAPACITOR BANK KLYSTRON AGING SET-UP  
 AND BEAM VOLTAGE CIRCUITRY-  
 DRAWN 12-98 TO REPLACE D349C105-  
 file:430\_105.ecw jbh 12-17-98 rev 8-7-02  
 file:430\_age.ecw jbh 2-24-03

## 2 **Pulse Aging**

- 2.1 New klystrons must be out gassed before applying RF. The procedure consists of pulsing the klystron with no RF drive and later transmitting short RF pulses and tuning for optimum conditions. The pulsing must be started with short pulses, about 20 microsecond, and an IPP of 100 ms (NO RF). After the high voltage is raised to 100 kV, bring it down, increase the PW and raise the voltage again slowly until there is an arc or you reach 100 kV. This second pulse width can be something like 60 microseconds.

If everything looks good lower the voltage to 70kV and start increasing the PW in 100 microsecond steps until the PW is 1 ms.

Shorten the PW to 500 Us and raise the voltage to 90kV. Start increasing the PW up to 1 ms. If there are no crowbars or noticeable arcs, raise the voltage to 100 kV and let the transmitter operate for about an hour.

Now the transmitter should be ready for tests at 6% duty 600 us PW, 10ms Ipp. If there are any crowbars or arcs during the test, lower the PW and voltage and start over.

## 3. **Tuning and RF Tests**

- 3.1 Set the PW to 20us, Ipp to 10ms. If the tube arcs or crowbars, come back to the same high voltage level and let the tube operate for 5 to 10 minutes.
- 3.2 The low frequency end of the turns is where they are fully in. Turning the drive CW will pull out the tuning rod, thus raising the resonant frequency of the cavity.

The tuner drives are powered through the eight toggle switches located below the oscilloscope on the console. They are 3-way spring return to center off switches. Holding the actuator upward turns the drive CW and raises the cavity frequency. Downward lowers the cavity frequency.

- 3.3 Test the tuner drive system by exercising the switches and observing the movement of the drives. Correct as needed. If the cables have been connect in their original positions, the tuners should operate normally.
- 3.4 At the console scope select RF output monitor of the tube to be tuned.
- 3.5 Set maget (solenoid) currents to values specified on the data sheet supplied for that particular tube.
- 3.6 Set each tuner to approximately the midway position.
- 3.7 Turn on HV and raise to 65kV.
- 3.8 apply RF drive. Use less than half the normal operating value.
- 3.9 Tune Cavity #1 for some output power and minimum reflected power to the IPA.
- 3.10 Tune Cavities 2,3, and 4 for maximum power output.



- 3.11 Raise the 3rd cavity away fro resonance. You can count slowly to ten and let it stand there. (Hold switch in the raise position for about 10 seconds).
- 3.12 Increase the RF drive to about 2/3 noral
- 3.13 Raise the high voltage to 980kV. Keep the tube outputs in phase by lowering the water load power using the actuator at the left of the tuning switches. Watch the body current meter. if body current is excessive, try retuning Cavity #2 slightly.
- 3.14 Tune Cavities 2 and 4 for maximum power output.
- 3.15 Raise high voltage to 95kV and run for 15 minutes while monitoring power output. Touch up tuning as warm up proceeds. Check Cavity #3. If tuning to a lower frequency raises the power output, the tuning is correct. Keep this cavity tuned at a higher frequency at all times to avoid damaging the klystron.
- 3.16 Raise high voltage to 100KkV. Adjust the phasing and trim the tuning if necessary.
- 3.17 Raise the high voltage to about 104kV for full power.

### 20.3 Klystron Magnet Currents

The procedures given above make no mention of the klystron magnet currents. The Litton manual for the L3403 says *“Turn on the electromagnets and adjust current in each of the coils to the values given in the test data summary sheet. These coil currents are later used to optimize rf output and other operating parameters (such as body current) and should be variable. These current values should be interpreted as nominal. Under-current and over-current interlocks are recommended for each of the focus coil controls.”* (Note that our transmitter was built with only under-current interlocks).

Later the Litton manual describes adjusting the magnets prior to tune-up: *“After 15 minutes of heater warm-up, the anode voltage may be turned on and raised to 40kV. Check body current, beam current, and vac-ion reading. Trimming of solenoid currents may be done now if nexessary. Body current may be minimized with coils 1 through 7 (supplies 1 through 5). It is not advisable to minimize body current by increasing number 8 coil 9supply 6) current beyond 5A (unless specified int eh Test Data Summary) since this will lower final power output of the tube.”*

**Note from the above that Litton uses 6 power supplies. Supply #1 powers coil #1. Supply #2 powers coils #2,#3, and #4. Supplies 3 through 6 power coils 5 through 8.**

### 24. Troubleshooting

The following list is not complete, but provides a start for troubleshooting.

Heat Exchanger

Breaker off or open relay coil

Low Water	Check gauge in the 30 gal. tank on the wall above the heat exchanger pad. If the water level is correct, depress the <i>Emergency Off</i> switch and restart the transmitter.
Kly A and/or b Collector Flow Mag. Flow, Dummy and Waster Load Flow	Check the meter gauges in the water manifold. Check the hoses. Check for clogged filter at the pump house.
Temperatures: Magnet, Collector Body, Tuner	Check for broken hoses, low flow
4160 phase failure	Blown 1/4A fuses inside O.C.B. cabinet inside HV room, right-hand side of entrance door. Watch for 208 V at this place. Fuses are inside red connector box.
Kly A or B reflected power	Push <i>Reset</i> on reflected power alarm chassis in console.
Magnet Current	Check 16 circuit breakers.
Kly A or B Tuner Cooling Air	Wait about two minutes when turning on for compressor to reach operating pressure. Check gauge at apron of klystron tank. This should read about 20 lbs.
Crowbar fired	Press PA Reset
Crowbar On	Check circuit breaker
Beam Supply meters	Check beam voltage, collector current, body current, or beam current meters. Press <i>PA Reset</i> to unlock. Then check modulator waveform on scope.
HV Vault Door	Turn console key
Capacitor Fault	Press PA Reset. If fault persists, check meter located at lower beam holding capacitor in HV room, in front of the entrance door.
Beam Supply fault current	Press PA Reset, check modulator waveform.

Inductrol Zero Set	Wait two minutes after momentary shut down. Comes on as soon as Inductrol runs down to zero setting.
No RF output	Check high reflected power alarm indicators, press RESET button on reflected power alarm chassis. <i>Press PA Reset.</i>

Trouble shooting by operators  
IPA

Be sure the IPA power is turned on (switch on the IPA rack in the transmitter room).

PA system, including low-level stages

Normally the orange light must come after 15 minutes. If this doesn't happen, check the interlock indicator lights at the lower left-hand apron of the console. If a string of lights is off, the *first* unlit light will indicate which circuit is not functioning properly. If all lights are on, the orange light is on, but, if upon pushing the *HV On* button, the red light doesn't stay on, press the *Reset* button for two to five seconds and then press the *HV On* button again. If the trouble persists, position the scope selector switch to *Mod Anode* and press the *PA Reset* button. A square pulse should appear. If it doesn't, the trouble is in the carriage house circuit for the waveguide switch. If the pulse does appear, then the power supply safety shoring bars are at fault.

If any circuit is shown faulty by the indicator lights, check the lower four rows of indicators for the circuit breakers. If a light is off here (except for the spares) the circuit is dead. It can be reset by going to the left-hand rear side of the console where a bank of circuit breakers can be seen. Reset any breakers you find tripped.

## 25. Glossary, Acronyms and Abbreviations

**Body Current** That portion of the klystron beam current that strays off axis and hits the outside (grounded) drift tube body instead of reaching the collector. Ideally the body current is zero. An internal arc or a waveguide will produce high body current and the body current sensor circuit will fire the crowbar to protect the klystrons. Note, however, that the body current sensor actually reads 'ground fault' current, i.e. current that gets from the B- bus to ground through any path whatsoever, inside or outside the klystrons.

**Buffer Deck** The chassis in the modulator which is "ground" for V401, the tail clipper or "off" tube. This chassis is biased to -5kV with respect to the klystron cathodes.

**BPF** Band- Pass Filter

CW	Continuous Wave - used to denote a steady sinewave signal - unmodulated, except for relatively infrequent turn on/turn off.
Diplexer	Device to permit transmission and reception from the same antenna. Active diplexers are called T/R (Transmit/Receive) switches.
DP11	The switch tubes originally used in the modulator (V301 and V401). Replaced by Machlett ML8038
IPA	Intermediate Power Amplifier - a small single-klystron amplifier that supplies about 200W of drive power to the output klystrons.
IPP	Interpulse period (reciprocal of PRF)
Floating Deck	The chassis in the modulator which is tied to the mod anode and "ground" for V301, the switch tube.
Ground Deck deck.	Chassis that generated high power 81 MHz pulse to trigger floating deck and buffer deck. Eliminated on installation of fiber optic control of modulator.
PA	Power Amplifier - the 2.5 MW "final" amplifier, comprising two L-3403 klystrons
PRF	Pulse Repetition Frequency (reciprocal of IPP)
Refl. Power Alarm	Console-mounted chassis containing two latched threshold detectors to sense diode detected voltages from reflected power couplers on both klystrons. The output signal from the Reflected Power Alarm is one of the input signals at the Fast RF Shutoff chassis.

## 26. List of schematic diagrams and other associated documentation

The original documentation is contained in a five volume manual supplied by Radiation at Stanford. Volume 1 is a text covering the theory and operation of the transmitter while Volumes 2 through 4 contain the original schematic diagrams. These original schematics are listed below. Drawings which have been ~~crossed out~~ are obsolete.

Note: The key to the drawing numbers is as follows: Drawing D349-C001, for example is a size D drawing, project 349 (the transmitter model is PC349), department C, drawing number 1. Drawings 1-100 are block diagrams, etc. Drawings 101-200 are schematics. Drawings 201-300 are Wiring (cabling) diagrams. Drawings 301-399 are mechanical detail drawings.

Schematic Diagram Nomenclature and part numbering

Part numbers	System
0-99	PA
199-200	IPA
200-299	Ground Deck (replaced by fiber optic link)
300-399	Modulator - Floating Deck
400-499	Modulator - Buffer Deck
500-599	Mod anode monitoring circuit
600-699	Klystron magnets
700-799	
800A-899A	Crowbar, Part A
800B-899B	Crowbar, Part B
900-999	Klystron monitoring - temp, flow, etc
1000-1999	Arc detector
1100-1199	3Watt modulator
1200-1299	RF gate generator
1300-1399	Reflected Power monitoring
1400-1499	Fast RF shut-off circuit
1500-1599	Delayed Circuit

Drawing Title

Drawing Number

Cabinet Power Supply	D349C001
Prelim. Layout	D349C002
Block Diagram	<del>J349C003</del> 430_117
Assembly - Front Panel	D349C004
Assembly Magnet Supply Chassis	D349C005
Control Console Assy.	J349C006
Panel Assy	E349C007
Arc Detector Assy.	A349C008
Arc Detector Power Supply Assy.	A349C009
Transmitter Floor Plan	J349C010
Assembly - Reflected Power	D349C011
Assy. - VA Cavity Drive	E349C022
Schematic: Beam Supply Tank	<del>B349C101</del> 430_105
Schematic: Crowbar Circuit. Sect. B	<del>D349C102</del> 430_102
Schematic: Magnet Supply	J349C103
Schematic: Flow Manifold	D349C104
Schematic: Capacitor Bank Sheet 1 (150kV config.)	<del>D349C105</del> (p1) 430_105
Schematic: Capacitor Bank Sheet 2 (110kV config.)	<del>D349C105</del> (p2) 430_105

Schematic: AC Power Dist. Sheet 1 superceded by 430_106a.ecw jbh, 1998	<del>J349C106(p1)</del> 430_106
Schematic: AC Power Dist. Sheet 2 (Interlock chain)	<del>J349C106(p2)</del> 430_106
Schematic: Monitoring	<del>J349C107</del> 430_107
Schematic: Crowbar Circuit Sect. A	<del>E349C108</del> 430_102
Schematic: Elec. IPA Remote Control (C324C105)	C349C109
Schematic: Elec. IPA (Revised D324c101)	D349C110
<del>Schematic: Ground Deck (81 MHz link)</del> (obsolete: Ground Deck eliminated 1982, replaced by fiber optic link)	<del>D349C111</del>
Schematic: Floating and Buffer Decks	<del>J349C112</del> 430_112.
Schematic: Klystron Tank	<del>D349C113</del> 430_105 and 430_112.
Schematic: Arc Detector	<del>D349C114</del> 430_114
<del>Schematic: A102 Trigger Gen. Power Supply</del>	<del>B349C115</del>
Simplified Modulator Block Diagram	<del>E349C116</del> 430_116
Overall Block Diagram	<del>E349C117</del> 430_117
Schematic: Mod. Anode Monitoring Circuit.	<del>E349C118</del> Now included in 430_112
Pulse control block diagram	<del>E349C119</del> 430_119
<del>Schematic: 3-Watt Modulator</del>	<del>D349C120</del>
<del>Schematic: RF Gate Generator</del>	<del>D349C121</del>
<del>Schematic: -5 Delay Bds (2 Sheets)</del>	<del>J0255SL101-1</del>
Schematic: Fast RF Shut-off Circuit	<del>E349C122</del> Now included in 430_124
<del>Ground Deck HV and Bias Supply</del> (Ground deck eliminated 1982, replaced by fiber optic link)	<del>E349C123</del>
High Reflected Power Alarm	<del>D349C124</del> 430_124
<del>Schematic: PRR Output Amplifier</del>	<del>B349C125</del>
<del>Schematic: Delayed Standard Circuit</del>	<del>B349C126</del>
<del>Sorensen MD 6.3-15.9 6.3VDC Supply</del>	<del>C349C127</del>
Wiring Diagram Relay chassis IPA	C349C201
Wiring Diagram IPA Cabinet Interconnection	J349C202
Wiring Diagram Circuit breaker panel	D349C203
Wiring Diagram IPA mag. Power Supply Panel.	C349C204
Wiring Diagram IPA Interlock and CB ind. light panel	C349C205
Wiring Diagram TC Breaker & Interlock lights ind. panel	E349C206
Wiring Diagram IPA & PA Interlock bypass sw. panel	E349C207
1 5/8" coax layout	C349C208
Pwr. amp mag. supply adjust Kly A	C349C209
Pwr. amp mag. supply adjust Kly B	C349C210
PA Kly Filament Adjust Panel Kly A	C349C211
PA Kly Filament Adjust Panel Kly B	C349C212
Wiring Diagram IPA & PA Meter Panel	D349C213
Wiring Diagram Mag. Supply Meter Panel Kly A	C349C214
Wiring Diagram Mag. Supply Meter Panel Kly B	C349C215

Wiring Diagram Detected Power meters panel	D349C216
Wiring Diagram tuning & monitor switch panel	C349C217
Wiring Diagram system control panel	D349C218
Wiring Diagram Circuit Breaker Panel	E349C219
Wiring Diagram Relay Panel No. 1 (TB 17)	E349C220
Wiring Diagram Relay Panel No. 2 (TB 18)	E349C221
Wiring Diagram Mag. Sup. Cabinet	C349C222
Wiring Diagram Flow Monitor	D349C223
Wiring Diagram Console Interconnects	J349C224
Wiring Diagram Beam Supply Tank Control Circuit.	B349C225
Wiring Diagram Primary Power Control Cabinet	C349C226
Wiring Diagram Capacitor Bank	D349C227
Wiring Diagram Klystron enclosure interconnects	E349C228
Wiring Diagram Heat Exchanger	B349C230
Wiring Diagram Klystron Tank	C349C231
Wiring Diagram Dummy Load	B349C232
Coax. cable interconnection diagram	J349C233
Interconnecting cabling diagram	E349C234
JB "A" Interconnecting diagram	C349C235
JB "B" Interconnecting diagram	E349C236
JB "C" Interconnecting diagram	E349C237
JB "D" Interconnecting diagram	D349C238
<del>Wiring Diagram 3-Watt Modulator Cabinet</del>	<del>C349C239</del>
<del>Wiring Diagram Trigger Generator Panel</del>	<del>C349C240</del>
<del>Wiring Diagram 3-W Mod. Control Panel</del>	<del>C349C241</del>
Thyratron deck - crowbar "B"	C349C242
<del>Wiring Diagram High reflected pwr alarm sheet 1 of 3</del>	<del>D349C244(p1)</del>
<del>Wiring Diagram High reflected pwr alarm sheet 2 of 3</del>	<del>D349C244(p2)</del>
<del>Wiring Diagram High reflected pwr alarm sheet 3 of 3</del>	<del>D349C244(p3)</del>
<del>Wiring Diagram High reflected pwr alarm pwr supply</del>	<del>B349C245</del>

Unimportant mechanical drawings (e.g. panels & frames) are not listed below:

Complex waveguide	D349C305
430 MHz High Power Hybrid	D349C320
Klystron tank	E349C323
Klystron tank details	E349C324
Transition piece waveguide-to-coax	D349C353

## 25.1 Associated documentation

- GE Inductrol Manual
- Litton Instruction Manual for L-3403 Klystron
- Litton Klystron L-3403 Data Sheet

Litton "Electrical Tests L-5773" PT-1082 15-page test procedure 9/29/89  
 Litton L-5773 Klystron : Body Current Reduction Guidelines, 2-page memo, Feb. 2000  
 Litton L-5773 Tuning Procedure, 2-page memo, 9/9/99.  
 Litton "Heater Power Optimization L-5773 BMEWS Klystron" 1 page, 2/28/00.  
 Domingo Albino's Written Instructions for changing a klystron  
 Domingo Albino's written instructions for aging a klystron  
 Eimac data sheet for 3KM2000LA klystron (IPA)  
 The Care and Feeding of EIMAC External Cavity Power Klystrons,  
 Application Bulletin 10, EIMAC, 1963 (IPA Klystron)  
 Machlett Data Sheet ML-8038 (Modulator switch tubes)  
 Eimac Data Sheet 4-400A (modulator driver tubes)  
 Data sheet for 3E29 (modulator clamp tubes)  
 DeLaval Oil Purifier manual  
 General Electric Manual furnished with the high-power 2nd-harmonic filter  
 Vacuum circuit breaker manual (do we have it?)  
 Oil circuit breaker manual (do we have it?)  
 "430-MHz Transmitter Modulator Upgrade Design" Gene E. Tallmadge, July 1981, SRI  
 International, Prepared for Cornell University, NAIC.

**26.2 Schematic Diagram Package appended to this manual** (drawn in EasyCad 4.55)

Block Diagram	430_bloc1.ecw
Transmitter room floor plan	430_plan.ecw
AC power distribution overall	430_106.ecw
Monitoring & metering	430_107.ecw
New IPA	430_nipa.ecw
Capacitor bank and beam voltage circuitry	430_105 .ecw
High voltage circuitry temporary modifications for klystron aging	430_age .ecw
Crowbar	430_102.ecw
Arc detector	430_114.ecw
High reflected power alarm	430_124.ecw



Simplified modulator schematic	<i>430_1160.ecw</i>
Modulator schematic	<i>430_112.ecw</i>
Monoplexer driver	<i>430_mxdr.ecw</i>
Receiver Interlocks	<i>430_ysw.ecw</i>
Fast rf shut off chassis	<i>430_122.ecw</i>
Low level rf and gating	<i>430-120.ecw</i>
Pulse control block diagram	<i>430_119.ecw</i>
Timing generator	<i>430_timegen1</i>

**SECTION 27 Pending Modifications**

To: Victor Iguina, Joe Greene

From: Jon Hagen

Date: April 7, 2004, June 8, 2004, June 12, May 31, 2005, July 18, 2005

Subject: 430 Transmitter Priorities

1. Fix the klystron air pressure interlock switch
2. Test K19 (modulator overcurrent) for proper operation. Document the auxiliary relays associated with K19.
3. Install an auxiliary relay so that K19 (which turns on the magnet power supplies) doesn't divert so much current out of the interlock chain
4. Radiator replacement. Have quote from Young Radiator. Get additional quotes.
5. Test the arc detectors and repair if necessary.
6. Design and build a tube tester for 3E29 & 4-400 modulator tubes.
7. Troubleshoot magnet 8 of klystron A. Breaker trips. Turn breaker back on and magnet current does not appear until PA reset is pushed?? (Probable that one phase of the three feeding the magnet supplies has been connected to some relay?) For a start, locate a replacement circuit breaker and install it. (Procure spares for all the circuit breakers in the console).  
Restore magnet meter interlocks

8. Finish new high voltage bleeder chain: assemble and install five 3" corona rings.
9. Oil Cooler installation
10. Slow the eh tuner motors (slower motors or more gear reduction)
11. Increase the length of R25, the Nichrome resistor between the klystrons and the hv supply. The original design calls for 75 ohms, but the present resistor is less than 30 ohms. Install proper corona donuts along this resistor.
12. Expand the fiber transmitter box to include two additional outputs. Install 100 ohm pots on all four transmitters so that the light intensity can be reduced to test the thresholds of all four fiber links. Move this box outside the hv room, just to the side of the door. (Position it so that it will not be hit by the door to the room or the door to the klystron vault).
13. Test the two new fiber receiver cards: measure the link thresholds (see above) in air and then under oil. Let the cards operate in a dish of oil for at least several days. Recheck the thresholds.
14. Install the new fiber receivers on the modulator decks. For now, put the dual receivers in parallel to provide redundancy. (Later we may modify the decks so that the new fibers operate the 3E29 clamp tubes).
15. Rebuild hv meter tower using two 150M resistors. Move the rebuilt tower from the inconvenient position almost blocking the door to near the side wall between the two capacitor bank bays.
16. Update the manual to include documentation on the peak power meters.
17. Install the spare peak power meter head in the console with DPM to monitor the tx output, i.e. the power leaving the waveguide combiner.
18. Install console DPM for water temperature.
19. Install console DPM for oil temperature.
20. Install console meter (analog) for Duty cycle (10% f.s.) just a 1 ma meter with a series resistor of  $3\text{v}/1\text{ma} = 3\text{k}$  connected to a TTL pulse output - Beam pulse (for beam duty factor) or RF pulse (for RF duty factor).
21. Install analog console meter for waveguide reflected power ( Jaime's project).
22. Install a console panel meter, circuitry, and cabling to read high voltage from the bleeder chain.
23. Install console meter to measure eh tuner positions

24. Install console readouts for the klystron cavity tuner positions
25. receiver protection - monitor power incident on monoplexers/readout on console
26. Build frame for new crowbar trigger
27. Design/built new crowbar trigger circuitry
28. Install a radiation 'smoke detector' on the mezzanine (radiation safety)

## Section 28. Index

AC power control circuitry 16.0  
Antenna tuner 7.1  
Arc detectors 12.2.1  
Bandwidth 2.2  
Buffer deck 13.1  
Capacitor bank safety 22.1.4  
Chirp 5.1  
Collector 19.2  
Control signals 17.3.0  
Crowbar 3.2.1, 12.0  
Dummy load 8.0  
EH tuner 7.1  
Final amplifier circuitry 6.0  
Floating deck 13.1  
Glossary 25.0  
Harmonic filter 3.1.4  
High voltage vault 22.1.2  
High voltage power supply 3.2, 11.0  
Inductrol 11.0  
IPA 9.0  
Klystron frequency shift 5.1  
Klystron replacement procedure 2.02  
Klystron aging & tuning 20.2  
Klystrons 5.01, 5.02  
L-3403 klystrons 5.01  
L-5773 klystrons 5.02  
Linear joints 19.2  
Losses in the waveguide system 2.1  
Mod anode supply 11.1  
Modification history 3.4  
Modulator 13.0  
Modulator simplified schematic 13.1  
Modulator oil MDS 22.2.4  
Monitoring system 15.0  
Monoplexer 18.1  
Oil, modulator 13.4 22.2.4  
Oil testing 22.4.5  
Operation instructions 4.0  
PA (power amplifier) 3.1.3  
Platform RF components 3.1.5  
Receiver protection 18.0  
Reflected power shut-off 12.2  
Reset 16.2  
RF power metering 15.4

RF radiation hazards 22.1.8  
Rotary joint 19.1  
Safety and protection systems 22.0  
Schematic diagram list 26.0, 26.2  
Slotted line 19.2  
Specifications 2.0  
Timing system 17.  
Troubleshooting 24.0  
Turn-on sequencing 16.1  
Turnstile junctions 21.0  
Waveguide collector 19.2  
Waveguide system 19.0  
Waveguide system losses 2.1  
Waveguide reflections 19.3  
Waveguide tuner 19.4  
Waveguide power divider 20.0

