

Leica TS12P User Manual



Version 1.0
English

- when it has to be **right**

Leica
Geosystems

Introduction

Purchase

Congratulations on the purchase of a TS12P instrument.



This manual contains important safety directions as well as instructions for setting up the product and operating it. Refer to "1 Safety Directions" for further information. Read carefully through the User Manual before you switch on the product.

Product Identification

The type and serial number of your product are indicated on the type plate. Always refer to this information when you need to contact your agency or Leica Geosystems authorised service workshop.

Trademarks

- CompactFlash and CF are trademarks of SanDisk Corporation
 - *Bluetooth*[®] is a registered trademark of Bluetooth SIG, Inc.
- All other trademarks are the property of their respective owners.



Validity of this manual

	Description
General	This manual applies to the TS12P instruments. Differences between the various models are marked and described.
Telescope	<ul style="list-style-type: none"> • Measuring with IR mode: When measuring distances to a reflector with EDM mode "IR", the telescope uses a wide visible red laser beam, which emerges coaxially from the telescope's objective. • Measuring with RL mode and LO mode: When measuring distances with EDM modes "RL" and "LO", the telescope uses a narrow visible red laser beam, which emerges coaxially from the telescope's objective.

Available documentation

Name	Description/Format		
TS12P Quick Guide	Provides an overview of the product together with technical data and safety directions. Intended as a quick reference guide.	✓	✓
TS12P User Manual	All instructions required in order to operate the product to a basic level are contained in the User Manual. Provides an overview of the product together with technical data and safety directions.	-	✓

Name	Description/Format		
CS15 Quick Guide	Provides an overview of the product together with technical data and safety directions. Intended as a quick reference guide.	✓	✓
CS15 User Manual	All instructions required in order to operate the product to a basic level are contained in the User Manual. Provides an overview of the product together with technical data and safety directions.	-	✓
Viva Series Technical Reference Manual	Overall comprehensive guide to the product and application functions. Included are detailed descriptions of special software/hardware settings and software/hardware functions intended for technical specialists.	-	✓

Name	Description/Format		
TPS1200+/ TS12P/ TS30/TM30 Technical Reference Manual	Overall comprehensive guide to the system and program functions. Included are detailed descriptions of special software/hardware settings and software/hardware functions intended for technical specialists.	-	✓

Refer to the following resources for all TS12P documentation/software:

- the Leica USB documentation card
- <https://myworld.leica-geosystems.com>



myWorld@Leica Geosystems (<https://myworld.leica-geosystems.com>) offers a wide range of services, information and training material.

With direct access to myWorld, you are able to access all relevant services whenever it is convenient for you, 24 hours a day, 7 days per week. This increases your efficiency and keeps you and your equipment instantly updated with the latest information from Leica Geosystems.

Service	Description
myProducts	Add all Leica Geosystems products that you and your company own. View detailed information on your products, buy additional options or Customer Care Packages (CCPs), update your products with the latest software and keep up-to-date with the latest documentation.
myService	View the service history of your products in Leica Geosystems Service Centres and detailed information on the services performed on your products. For your products that are currently in Leica Geosystems Service Centres view the current service status and the expected end date of service.
mySupport	Create new support requests for your products that will be answered by your local Leica Geosystems Support Team. View the complete history of your Support and view detailed information on each request in case you want to refer to previous support requests.
myTraining	Enhance your product knowledge with the Leica Geosystems Campus - Information, Knowledge, Training. Study the latest online training material or download training material on your products. Keep up-to-date with the latest News on your products and register for Seminars or Courses in your country.
myTrusted Services	Offers increased productivity while at the same time providing maximum security. <ul style="list-style-type: none"> • myExchange With myExchange you can exchange any files/objects from your computer to any of your Leica Exchange Contacts. • mySecurity If your instrument is ever stolen, a locking mechanism is available to ensure that the instrument is disabled and can no longer be used.

Table of Contents

In this manual	Chapter	Page
1	Safety Directions	6
1.1	General Introduction	6
1.2	Definition of Use	6
1.3	Limits of Use	6
1.4	Responsibilities	7
1.5	Hazards of Use	7
1.6	Laser Classification	10
1.6.1	General	10
1.6.2	Distancer, Measurements with Reflectors	10
1.6.3	Distancer, Measurements without Reflectors	11
1.6.4	Red Laser Pointer	13
1.6.5	Automatic Target Aiming ATR	15
1.6.6	PowerSearch PS	16
1.6.7	Electronic Guide Light EGL	17
1.6.8	Laser Plummet	18
1.7	Electromagnetic Compatibility EMC	19
1.8	FCC Statement, Applicable in U.S.	20
2	Description of the System	22
2.1	System Components	22
2.2	System Concept	23
2.2.1	Software Concept	23
2.2.2	Data Storage and Data Conversion Concept	24
2.2.3	Power Concept	24
2.3	Container Contents	25
2.4	Instrument Components	28
3	User Interface	30
3.1	Keyboard	30
3.2	Screen	31
3.3	Operating Principles	32
3.4	Icons	35
4	Operation	36
4.1	Instrument Setup	36
4.2	Setting Up SmartPole	37
4.3	Setting up for Remote Control (with the RadioHandle)	37
4.4	Fixing the Field Controller to a Holder and Pole	38
4.5	Autodetect Behaviour	40
4.6	Instrument Setup for Remote Control	40
4.6.1	Remote Control Setup	40
4.6.2	LED Indicators on RadioHandle	41
4.7	Batteries	42
4.7.1	Operating Principles	42
4.7.2	Instrument Battery	42
4.8	Working with the CompactFlash Card	43
4.9	Guidelines for Correct Results	44

5	Check & Adjust	46
5.1	Overview	46
5.2	Preparation	47
5.3	Combined Adjustment (l, t, i, c and ATR)	48
5.4	Tilting Axis Adjustment (a)	50
5.5	Adjusting the Circular Level of the Instrument and Tribrach	52
5.6	Adjusting the Circular Level of the Prism Pole	52
5.7	Inspecting the Laser Plummet of the Instrument	53
5.8	Servicing the Tripod	54
6	Care and Transport	55
6.1	Transport	55
6.2	Storage	55
6.3	Cleaning and Drying	56
6.4	Maintenance	56
7	Technical Data	57
7.1	Angle Measurement	57
7.2	Distance Measurement with Reflectors	58
7.3	Distance Measurement without Reflectors	59
7.4	Distance Measurement - Long Range (LO mode)	60
7.5	Automatic Target Aiming ATR	61
7.6	PowerSearch PS	62
7.7	Conformity to National Regulations	63
	7.7.1 Communication side cover with Bluetooth	63
	7.7.2 RadioHandle	64
	7.7.3 Dangerous Goods Regulations	64
7.8	General Technical Data of the Instrument	65
7.9	Scale Correction	68
7.10	Reduction Formulas	71
8	Software Licence Agreement	73

1 Safety Directions

1.1 General Introduction

Description The following directions enable the person responsible for the product, and the person who actually uses the equipment, to anticipate and avoid operational hazards.

The person responsible for the product must ensure that all users understand these directions and adhere to them.

1.2 Definition of Use

Intended use

- Measuring horizontal and vertical angles.
- Measuring distances.
- Recording measurements.
- Automatic target search, recognition and following.
- Visualising the aiming direction and vertical axis.
- Remote control of product.
- Data communication with external appliances.
- Computing with software.

Reasonably Fore-seeable Misuse

- Use of the product without instruction.
- Use outside of the intended use and limits.
- Disabling safety systems.
- Removal of hazard notices.
- Opening the product using tools, for example screwdriver, unless this is permitted for certain functions.
- Modification or conversion of the product.
- Use after misappropriation.
- Use of products with obvious damages or defects.
- Use with accessories from other manufacturers without the prior explicit approval of Leica Geosystems.
- Inadequate safeguards at the working site.
- Aiming directly into the sun.

1.3 Limits of Use

Environment Suitable for use in an atmosphere appropriate for permanent human habitation: not suitable for use in aggressive or explosive environments.



DANGER

Local safety authorities and safety experts must be contacted before working in hazardous areas, or close to electrical installations or similar situations by the person in charge of the product.

1.4

Responsibilities

Manufacturer of the product

Leica Geosystems AG, CH-9435 Heerbrugg, hereinafter referred to as Leica Geosystems, is responsible for supplying the product, including the user manual and original accessories, in a safe condition.

Person responsible for the product

The person responsible for the product has the following duties:

- To understand the safety instructions on the product and the instructions in the user manual.
- To ensure that it is used in accordance with the instructions.
- To be familiar with local regulations relating to safety and accident prevention.
- To inform Leica Geosystems immediately if the product and the application becomes unsafe.
- To ensure that the national laws, regulations and conditions for the operation of e.g. radio transmitters or lasers are respected.

1.5

Hazards of Use



CAUTION

Watch out for erroneous measurement results if the product has been dropped or has been misused, modified, stored for long periods or transported.

Precautions:

Periodically carry out test measurements and perform the field adjustments indicated in the user manual, particularly after the product has been subjected to abnormal use and before and after important measurements.



DANGER

Because of the risk of electrocution, it is dangerous to use poles and extensions in the vicinity of electrical installations such as power cables or electrical railways.

Precautions:

Keep at a safe distance from electrical installations. If it is essential to work in this environment, first contact the safety authorities responsible for the electrical installations and follow their instructions.



NOTICE

With the remote control of products, it is possible that extraneous targets will be picked out and measured.

Precautions:

When measuring in remote control mode, always check your results for plausibility.



WARNING

If the product is used with accessories, for example masts, staffs, poles, you may increase the risk of being struck by lightning.

Precautions:

Do not use the product in a thunderstorm.



WARNING

During dynamic applications, for example stakeout procedures there is a danger of accidents occurring if the user does not pay attention to the environmental conditions around, for example obstacles, excavations or traffic.

Precautions:

The person responsible for the product must make all users fully aware of the existing dangers.

**WARNING**

Inadequate securing of the working site can lead to dangerous situations, for example in traffic, on building sites, and at industrial installations.

Precautions:

Always ensure that the working site is adequately secured. Adhere to the regulations governing safety and accident prevention and road traffic.

**CAUTION**

Be careful when pointing the product towards the sun, because the telescope functions as a magnifying glass and can injure your eyes and/or cause damage inside the product.

Precautions:

Do not point the product directly at the sun.

**CAUTION**

If the accessories used with the product are not properly secured and the product is subjected to mechanical shock, for example blows or falling, the product may be damaged or people can sustain injury.

Precautions:

When setting-up the product, make sure that the accessories are correctly adapted, fitted, secured, and locked in position.

Avoid subjecting the product to mechanical stress.

**WARNING**

During the transport, shipping or disposal of batteries it is possible for inappropriate mechanical influences to constitute a fire hazard.

Precautions:

Before shipping the product or disposing of it, discharge the batteries by running the product until they are flat.

When transporting or shipping batteries, the person in charge of the product must ensure that the applicable national and international rules and regulations are observed. Before transportation or shipping contact your local passenger or freight transport company.

**WARNING**

High mechanical stress, high ambient temperatures or immersion into fluids can cause leakage, fire or explosions of the batteries.

Precautions:

Protect the batteries from mechanical influences and high ambient temperatures. Do not drop or immerse batteries into fluids.

**WARNING**

If battery terminals are short circuited e.g. by coming in contact with jewellery, keys, metalized paper or other metals, the battery can overheat and cause injury or fire, for example by storing or transporting in pockets.

Precautions:

Make sure that the battery terminals do not come into contact with metallic objects.



WARNING

If the product is improperly disposed of, the following can happen:

- If polymer parts are burnt, poisonous gases are produced which may impair health.
- If batteries are damaged or are heated strongly, they can explode and cause poisoning, burning, corrosion or environmental contamination.
- By disposing of the product irresponsibly you may enable unauthorised persons to use it in contravention of the regulations, exposing themselves and third parties to the risk of severe injury and rendering the environment liable to contamination.

Precautions:

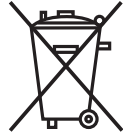

The product must not be disposed with household waste.

Dispose of the product appropriately in accordance with the national regulations in force in your country.

Always prevent access to the product by unauthorised personnel.

Product-specific treatment and waste management information can be downloaded from the Leica Geosystems home page at <http://www.leica-geosystems.com/treatment> or received from your Leica Geosystems dealer.



WARNING

Only Leica Geosystems authorised service workshops are entitled to repair these products.

1.6



Laser Classification

1.6.1

General

General

The following chapters provide instructions and training information about laser safety according to international standard IEC 60825-1 (2014-05) and technical report IEC TR 60825-14 (2004-02). The information enables the person responsible for the product and the person who actually uses the equipment, to anticipate and avoid operational hazards.

-  According to IEC TR 60825-14 (2004-02), products classified as laser class 1, class 2 and class 3R do not require:
 - laser safety officer involvement,
 - protective clothes and eyewear,
 - special warning signs in the laser working areaif used and operated as defined in this User Manual due to the low eye hazard level.
-  National laws and local regulations could impose more stringent instructions for the safe use of lasers than IEC 60825-1 (2014-05) and IEC TR 60825-14 (2004-02).

1.6.2

Distancer, Measurements with Reflectors

General

The EDM module built into the product produces a visible laser beam which emerges from the telescope objective.

The laser product described in this section is classified as laser class 1 in accordance with:

- IEC 60825-1 (2014-05): "Safety of laser products"

These products are safe under reasonably foreseeable conditions of operation and are not harmful to the eyes provided that the products are used and maintained in accordance with this User Manual.

Description	Value
Wavelength	658 nm
Pulse duration	800 ps
Pulse repetition frequency (PRF)	100 MHz
Maximum average radiant power	0.33 mW
Beam divergence	1.5 mrad x 3 mrad

Labelling

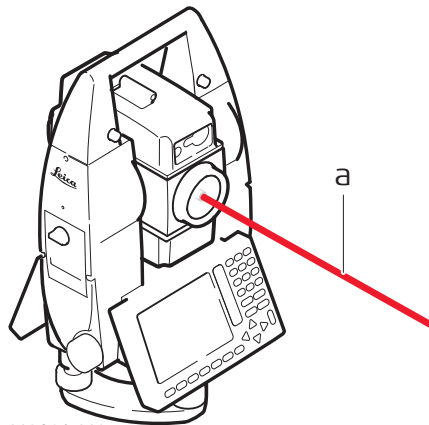

a) Laser beam

General

The EDM module built into the product produces a visible laser beam which emerges from the telescope objective.

The laser product described in this section is classified as laser class 3R in accordance with:

- IEC 60825-1 (2014-05): "Safety of laser products"

Direct intrabeam viewing may be hazardous (low eye hazard level), in particular for deliberate ocular exposure. The beam may cause dazzle, flash-blindness and after-images, particularly under low ambient light conditions. The risk of injury for laser class 3R products is limited because of:

- unintentional exposure would rarely reflect worst case conditions of (e.g.) beam alignment with the pupil, worst case accommodation,
- inherent safety margin in the maximum permissible exposure to laser radiation (MPE)
- natural aversion behaviour for exposure to bright light for the case of visible radiation.

Description	Value (R400/R1000)
Wavelength	658 nm
Maximum average radiant power	4.8 mW
Pulse duration	800 ps
Pulse repetition frequency (PRF)	100 MHz
Beam divergence	0.2 mrad x 0.3 mrad
NOHD (Nominal Ocular Hazard Distance) @ 0.25s	44 m

**CAUTION**

From a safety perspective, class 3R laser products should be treated as potentially hazardous.

Precautions:

- 1) Prevent direct eye exposure to the beam.
- 2) Do not direct the beam at other people.

**CAUTION**

Potential hazards are not only related to direct beams but also to reflected beams aimed at reflecting surfaces such as prisms, windows, mirrors, metallic surfaces, etc.

Precautions:

- 1) Do not aim at areas that are essentially reflective, such as a mirror, or which could emit unwanted reflections.
- 2) Do not look through or beside the optical sight at prisms or reflecting objects when the laser is switched on, in laser pointer or distance measurement mode. Aiming at prisms is only permitted when looking through the telescope.

Labelling

Laser Radiation
 Avoid direct eye exposure
 Class 3R Laser Product
 according to IEC 60825-1
 (2014 - 05)
 $P_{av} = 4.8 \text{ mW}$
 $\lambda = 658 \text{ nm}$
 $t_p = 800 \text{ ps}$

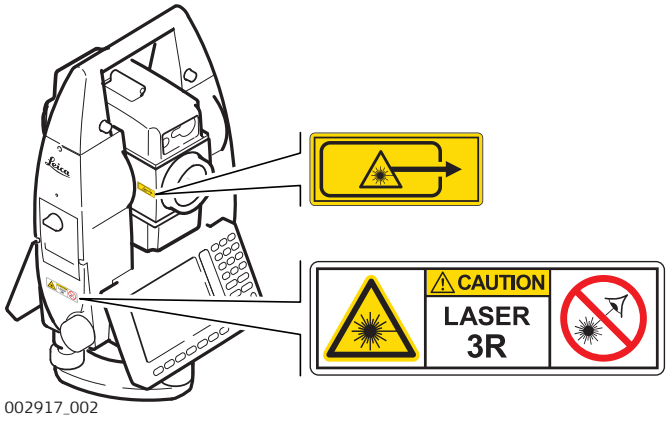

Type: TS12P **Art.No.:** 1 2 3 4 5 6
Equip.No.: 1234567
Power: 12V/7,4V \approx , 1A max **S.No.:** 1 2 3 4 5 6
Leica Geosystems AG
CH-9435 Heerbrugg
Manufactured: 20XX
Made in Switzerland

Complies with FDA performance standards for laser products except for deviations pursuant to Laser Notice No. 50, dated June 24, 2007.
 This device complies with part 15 of the FCC Rules.
 Operation is subject to the following two conditions:
 (1) This device may not cause harmful interference, and
 (2) This device must accept any interference received, including interference that may cause undesired operation.

$P_{av} = 4.8\text{mW}$ $\lambda = 658\text{nm}$ $t_p = 800\text{ps}$
 IEC 60825-1:2014

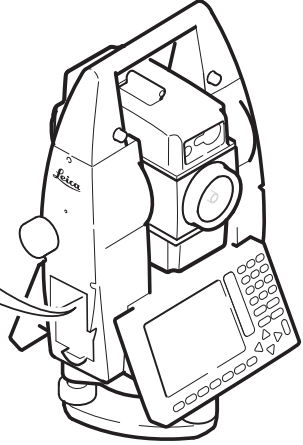

General

The laser pointer built into the product produces a visible red laser beam which emerges from the telescope objective.

The laser product described in this section is classified as laser class 3R in accordance with:

- IEC 60825-1 (2014-05): "Safety of laser products"

Direct intrabeam viewing may be hazardous (low eye hazard level), in particular for deliberate ocular exposure. The beam may cause dazzle, flash-blindness and after-images, particularly under low ambient light conditions. The risk of injury for laser class 3R products is limited because of:

- unintentional exposure would rarely reflect worst case conditions of (e.g.) beam alignment with the pupil, worst case accommodation,
- inherent safety margin in the maximum permissible exposure to laser radiation (MPE)
- natural aversion behaviour for exposure to bright light for the case of visible radiation.

Description	Value (R400/R1000)
Wavelength	658 nm
Maximum average radiant power	4.8 mW
Pulse duration	800 ps
Pulse repetition frequency (PRF)	100 MHz
Beam divergence	0.2 mrad x 0.3 mrad
NOHD (Nominal Ocular Hazard Distance) @ 0.25s	44 m

**CAUTION**

From a safety perspective, class 3R laser products should be treated as potentially hazardous.

Precautions:

- 1) Prevent direct eye exposure to the beam.
- 2) Do not direct the beam at other people.

**CAUTION**

Potential hazards are not only related to direct beams but also to reflected beams aimed at reflecting surfaces such as prisms, windows, mirrors, metallic surfaces, etc.

Precautions:

- 1) Do not aim at areas that are essentially reflective, such as a mirror, or which could emit unwanted reflections.
- 2) Do not look through or beside the optical sight at prisms or reflecting objects when the laser is switched on, in laser pointer or distance measurement mode. Aiming at prisms is only permitted when looking through the telescope.

Labelling

Laser Radiation
 Avoid direct eye exposure
 Class 3R Laser Product
 according to IEC 60825-1
 (2014 - 05)
 $P_{av} = 4.8 \text{ mW}$
 $\lambda = 658 \text{ nm}$
 $t_p = 800 \text{ ps}$

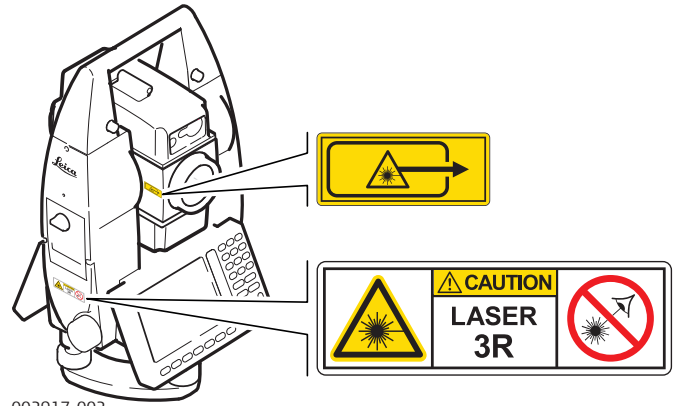

002917_002

Type: TS12P **Art.No.:** 1 2 3 4 5 6
Equip.No.: 1234567
Power: 12V/7,4V \approx , 1A max **S.No.:** 1 2 3 4 5 6
Leica Geosystems AG
CH-9435 Heerbrugg
Manufactured: 20XX
Made in Switzerland

Complies with FDA performance standards for laser products except for deviations pursuant to Laser Notice No. 50, dated June 24, 2007.
 This device complies with part 15 of the FCC Rules.
 Operation is subject to the following two conditions:
 (1) This device may not cause harmful interference, and
 (2) This device must accept any interference received, including interference that may cause undesired operation.

$P_{av} = 4.8\text{mW}$ $\lambda = 658\text{nm}$ $t_p = 800\text{ps}$
 IEC 60825-1:2014

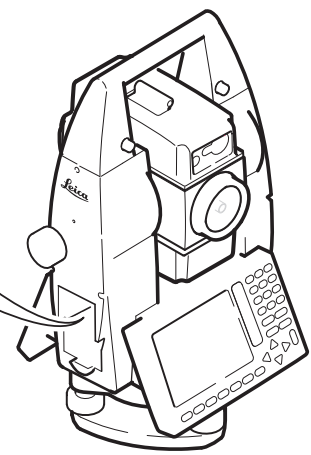

002763_002

1.6.5

Automatic Target Aiming ATR

General

The Automatic Target Aiming built into the product produces an invisible laser beam which emerges from the telescope objective.

The laser product described in this section is classified as laser class 1 in accordance with:

- IEC 60825-1 (2014-05): "Safety of laser products"

These products are safe under reasonably foreseeable conditions of operation and are not harmful to the eyes provided that the products are used and maintained in accordance with this User Manual.

Description	Value
Wavelength	785 nm
Maximum average radiant power	3 mW
Pulse duration	≤ 17 ms
Pulse repetition frequency (PRF)	≤ 29 Hz
Beam divergence	11 mrad

Labelling

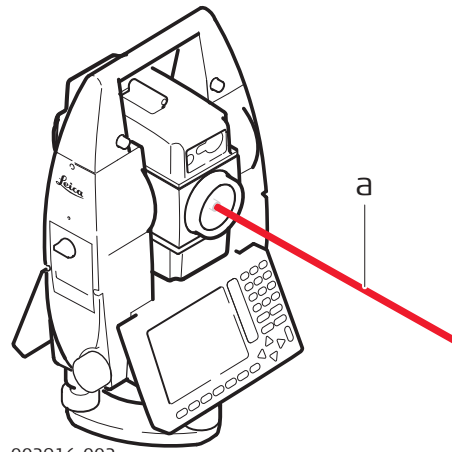

a) Laser beam

General

The PowerSearch built into the product produces an invisible laser beam which emerges from the front side of the telescope.

The laser product described in this section is classified as laser class 1 in accordance with:

- IEC 60825-1 (2014-05): "Safety of laser products"

These products are safe under reasonably foreseeable conditions of operation and are not harmful to the eyes provided that the products are used and maintained in accordance with this User Manual.

Description	Value
Wavelength	850 nm
Maximum average radiant power	11 mW
Pulse duration	20 ns, 40 ns
Pulse repetition frequency (PRF)	24.4 kHz
Beam divergence	0.4 mrad x 700 mrad

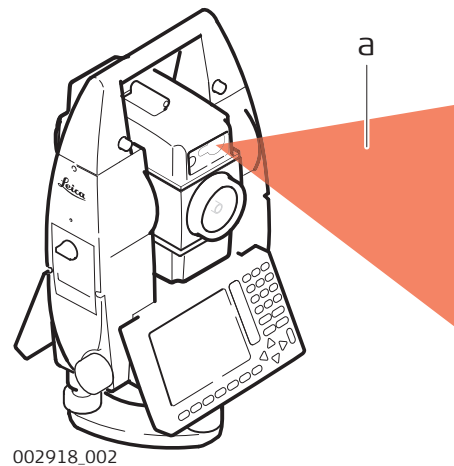
Labelling

002918_002

a) Laser beam

General

The Electronic Guide Light built into the product produces a visible LED beam which emerges from the front side of the telescope.

- ☞ The product described in this section, is excluded from the scope of IEC 60825-1 (2014-05): "Safety of laser products".
The product described in this section, is classified as exempt group in accordance with IEC 62471 (2006-07) and does not pose any hazard provided that the product is used and maintained in accordance with this user manual.

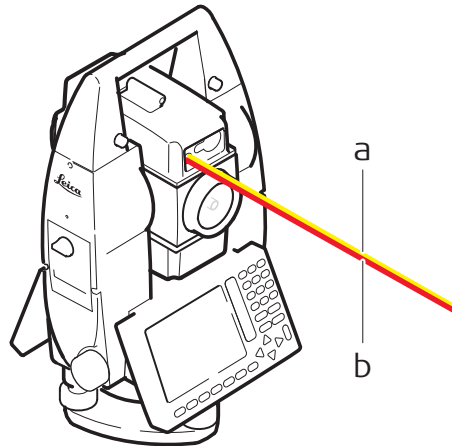

002919_002

- a) LED beam red
b) LED beam yellow

1.6.8

Laser Plummet

General

The laser plummet built into the product produces a visible red laser beam which emerges from the bottom of the product.

The laser product described in this section is classified as laser class 2 in accordance with:

- IEC 60825-1 (2014-05): "Safety of laser products"

These products are safe for momentary exposures but can be hazardous for deliberate staring into the beam. The beam may cause dazzle, flash-blindness and after-images, particularly under low ambient light conditions.

Description	Value
Wavelength	640 nm
Maximum average radiant power	0.95 mW
Pulse duration	10 ms - cw
Pulse repetition frequency (PRF)	1 kHz
Beam divergence	< 1.5 mrad



CAUTION

From a safety perspective, class 2 laser products are not inherently safe for the eyes.

Precautions:

- 1) Avoid staring into the beam or viewing it through optical instruments.
- 2) Avoid pointing the beam at other people or at animals.

Labelling

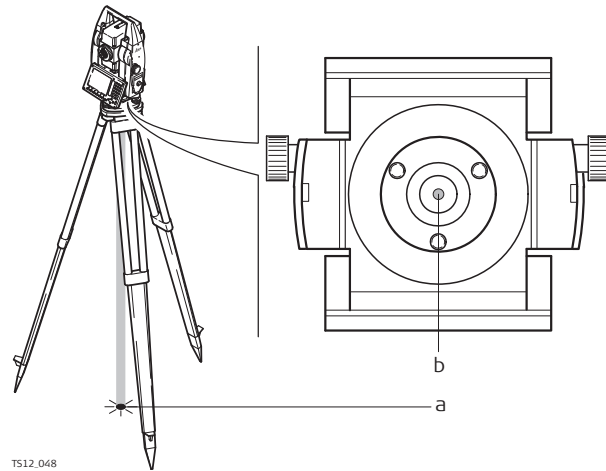

Laser Radiation
Do not stare into the beam
Class 2 Laser Product
according to IEC 60825-1
(2014 - 05)
 $P_{av} = 0.95 \text{ mW}$
 $\lambda = 640 \text{ nm}$
 $t_p = 10 \text{ ms - cw}$

- a) Laser beam
b) Exit for laser beam

Description

The term Electromagnetic Compatibility is taken to mean the capability of the product to function smoothly in an environment where electromagnetic radiation and electrostatic discharges are present, and without causing electromagnetic disturbances to other equipment.

**WARNING**

Electromagnetic radiation can cause disturbances in other equipment. Although the product meets the strict regulations and standards which are in force in this respect, Leica Geosystems cannot completely exclude the possibility that other equipment may be disturbed.

**CAUTION**

There is a risk that disturbances may be caused in other equipment if the product is used with accessories from other manufacturers, for example field computers, personal computers or other electronic equipment, non-standard cables or external batteries.

Precautions:

Use only the equipment and accessories recommended by Leica Geosystems. When combined with the product, they meet the strict requirements stipulated by the guidelines and standards. When using computers or other electronic equipment, pay attention to the information about electromagnetic compatibility provided by the manufacturer.

**CAUTION**

Disturbances caused by electromagnetic radiation can result in erroneous measurements.

Although the product meets the strict regulations and standards which are in force in this respect, Leica Geosystems cannot completely exclude the possibility that the product may be disturbed by intense electromagnetic radiation, for example, near radio transmitters, two-way radios or diesel generators.

Precautions:

Check the plausibility of results obtained under these conditions.

**CAUTION**

If the product is operated with connecting cables attached at only one of their two ends, for example external supply cables, interface cables, the permitted level of electromagnetic radiation may be exceeded and the correct functioning of other products may be impaired.

Precautions:

While the product is in use, connecting cables, for example product to external battery, product to computer, must be connected at both ends.

Radios or Digital Cellular Phones**WARNING**

Use of product with radio or digital cellular phone devices:

Electromagnetic fields can cause disturbances in other equipment, in installations, in medical devices, for example pacemakers or hearing aids and in aircraft. It can also affect humans and animals.

Precautions:

Although the product meets the strict regulations and standards which are in force in this respect, Leica Geosystems cannot completely exclude the possibility that other equipment can be disturbed or that humans or animals can be affected.

- Do not operate the product with radio or digital cellular phone devices in the vicinity of filling stations or chemical installations, or in other areas where an explosion hazard exists.
- Do not operate the product with radio or digital cellular phone devices near to medical equipment.
- Do not operate the product with radio or digital cellular phone devices in aircraft.



The greyed paragraph below is only applicable for products without radio.



WARNING

This equipment has been tested and found to comply with the limits for a Class B digital device, pursuant to part 15 of the FCC rules. These limits are designed to provide reasonable protection against harmful interference in a residential installation. This equipment generates, uses and can radiate radio frequency energy and, if not installed and used in accordance with the instructions, may cause harmful interference to radio communications. However, there is no guarantee that interference will not occur in a particular installation. If this equipment does cause harmful interference to radio or television reception, which can be determined by turning the equipment off and on, the user is encouraged to try to correct the interference by one or more of the following measures:

- Reorient or relocate the receiving antenna.
- Increase the separation between the equipment and the receiver.
- Connect the equipment into an outlet on a circuit different from that to which the receiver is connected.
- Consult the dealer or an experienced radio/TV technician for help.



WARNING

Changes or modifications not expressly approved by Leica Geosystems for compliance could void the user's authority to operate the equipment.

Labelling TS12P

Type: TS12P Art.No.: 1 2 3 4 5 6
 Equip.No.: 1234567
 Power: 12V/7,4V , 1A max S.No.: 1 2 3 4 5 6
 Leica Geosystems AG
 CH-9435 Heerbrugg
 Manufactured: 20XX
 Made in Switzerland

Complies with FDA performance standards for laser products except for deviations pursuant to Laser Notice No. 50, dated June 24, 2007.
 This device complies with part 15 of the FCC Rules.
 Operation is subject to the following two conditions:
 (1) This device may not cause harmful interference, and
 (2) This device must accept any interference received, including interference that may cause undesired operation.

Pav = 4.8mW λ = 658nm tp = 800ps
 IEC 60825-1:2014

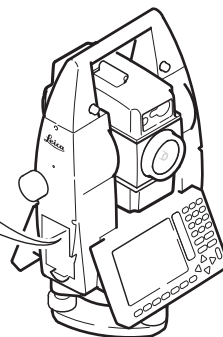

002763_002

Labelling internal battery GEB222



Type: GEB222 Art.No.: 793973
 Li-Ion Battery: 7.4V /6.0Ah
 15A 5A/130°C 44.4Wh

Leica Geosystems AG, CH-9435 Heerbrugg
 S.No.: 10142 Made in China

This device complies with part 15 of the FCC Rules. Operation is subject to the following two conditions: (1) This device may not cause harmful interference, and (2) this device must accept any interference received, including interference that may cause undesired operation.

11WE
 MH29443

005043_001

**Labelling
RadioHandle**

RH16



Type: RH16

Art.No. : 777812
Power: 7.4V/12.5V= \approx /0.2A max.

Leica Geosystems AG
CH-9435 Heerbrugg
Manufactured: 20xx
Made in Switzerland

Contains
Transmitter Module:
FCC ID: HSW-2400M
IC: 4492A-2450



This device complies with part 15 of the FCC Rules. Operation is subject to the following two conditions: (1) This device may not cause harmful interference, and (2) this device must accept any interference received, including interference that may cause undesired operation.

S.No.: 1234567

008612.001

RH17



Type: RH17

Art.No. : 818467
Power: 7.4V/12.5V= \approx /0.2A max.

Leica Geosystems AG
CH-9435 Heerbrugg
Manufactured: 20xx
Made in Switzerland

Contains
Transmitter Module:
FCC ID: PVH0946
IC: 5325A-0946



This device complies with part 15 of the FCC Rules. Operation is subject to the following two conditions: (1) This device may not cause harmful interference, and (2) this device must accept any interference received, including interference that may cause undesired operation.

S.No.: 1234567

008613.001

2

Description of the System

2.1

System Components

Main components

Component	Description
TS12P	<ul style="list-style-type: none">• a total station for measuring, calculating and capturing data.• consisting of various models with a range of accuracy classes.• combined with the multi-purpose CS15 radio field controller to conduct remote control surveys.
CS15 field controller	A multi-purpose field controller enabling the remote control of TS12P.
Leica Geo Office/Infinity	The office software including a series of help programs which support working with Leica instruments.

Terminology

The following terms and abbreviations may be found in this manual:

Term	Description
TPS	T otal S tation P ositioning S ystem
RCS	R emote C ontrol S urveying
LGO	L EICA G eo O ffice
EDM	E lectronic D istance M easurement EDM refers to the laser distancer incorporated into the instrument which enables distance measurement. Three measuring modes are available: <ul style="list-style-type: none">• IR mode. This mode refers to the ability to measure distances to prisms.• RL mode. This mode refers to the ability to measure distances without prisms.• LO mode. This mode refers to the visible red laser and the ability to measure extended distances to prisms.
PinPoint	PinPoint refers to the reflectorless EDM technology which enables an increased measuring range with a smaller laser spot size. Two options are available: R400 and R1000.
EGL	E lectronic G uide L ight An EGL fitted to an instrument assists with prism targeting. It consists of two differently coloured flashing lights located in the instrument telescope housing. The person holding the prism can align him/herself into the instrument's line of sight.
Motorised	Instruments fitted with internal motors, enabling automatic horizontal and vertical turning are referred to as M otorised.
ATR	A utomated T arget A iming. ATR refers to the instrument sensor which enables the automatic target aiming to a prism.
Automated	Instruments fitted with T arget a iming are referred to as A uto- m ated.

Term	Description
	Three automation modes are available with Target aiming : <ul style="list-style-type: none"> • None: no Target aiming - no automation and no tracking. • ATR: automatic target aiming to a prism. • LOCK: automatic tracking of an already targeted prism.
PowerSearch	PowerSearch refers to the instrument sensor which enables the automatic rapid finding of a prism.
RadioHandle	A component of RCS is the RH16/RH17 RadioHandle. It is an instrument carry handle with an integrated long range Bluetooth module with attached antenna.
Communication side cover	Communication side cover with integrated Bluetooth. In combination with the RH16/RH17 RadioHandle, it is also a component of RCS.

Instrument models

Model	Description
TS12P	Reflectorless EDM, Automated, Motorised, PowerSearch .

2.2

System Concept

2.2.1

Software Concept

Description

All instruments use the same software concept.

Software type

Software type	Description
System software	This software comprises the central functions of the instrument. It is also referred to as firmware. The programs Survey and Setup are integrated into the firmware and cannot be deleted. The English language is integrated into the firmware and cannot be deleted.
Language software	Numerous languages are available for the instruments. This software is also referred to as system language. The system software enables a maximum of three languages which can be stored at any one time - the English language and two other languages. The English language is the default language and cannot be deleted. One language is chosen as the active language.
Application programs	A suite of optional survey-specific application programs are available for the instrument. Some of the programs are activated freely and require no licence key and others require purchasing and are only activated with a licence key.

Software upload

The instrument firmware is stored in the System RAM of the instrument. The firmware can be uploaded onto the instrument using the following method:

- By connecting the CompactFlash card directly to the computer either via an internal card slot housing or an external OMNI drive, the software is transferred to the card, which is then stored to the System RAM.

2.2.2

Data Storage and Data Conversion Concept

Description

Data is stored within a job in a database on a CompactFlash card.

Memory device

CompactFlash card: A CompactFlash card housing is standard. A CompactFlash card can be inserted and removed. Available capacity: 256 MB and 1 GB

 Whilst other CompactFlash cards may be used, Leica recommends Leica CompactFlash cards and cannot be held responsible for data loss or any other error that may occur when using a non-Leica card.



Unplugging connecting cables or removing the CompactFlash card during the Check & Adjust routine may cause loss of data. Always return to the **Main Menu** before removing the CompactFlash card and switch off the instrument before removing cables.

Data conversion

Export

Data can be exported from a job in a wide range of ASCII formats. The export format is defined in Format Manager which is a PC tool in Leica Geo Office. Refer to the online help of LGO for information on creating format files.



CompactFlash cards can be used directly in an OMNI drive as supported by Leica Geosystems. Other PC card drives may require an adapter.

2.2.3

Power Concept

General

Use the batteries, chargers and accessories recommended by Leica Geosystems to ensure the correct functionality of the instrument.

Power options

Instrument

Power for the instrument can be supplied either internally or externally. An external battery is connected to the instrument using a LEMO cable.

Internal battery: One GEB222 battery fitted into the battery compartment.
External battery: One GEB371 battery connected via cable.

2.3

Container Contents

Container for instrument and accessories part 1 of 2

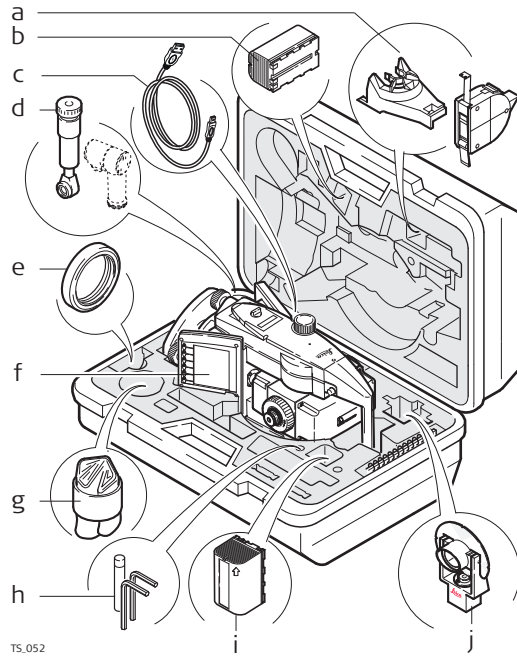

TS.052

- a) GHM007 Instrument height meter and GHT196 tribrach bracket for height meter
- b) GEB222 battery
- c) Data transfer cable
- d) GFZ3 or GOK6 diagonal eyepiece
- e) Counterweight for diagonal eyepiece
- f) Instrument with tribrach and standard handle or RadioHandle
- g) Protective cover for instrument, sunshade for objective lens and cleaning cloth
- h) Allen key
- i) GEB222 battery
- j) GMP101 mini prism

**Container for
instrument and
accessories
part 2 of 2**

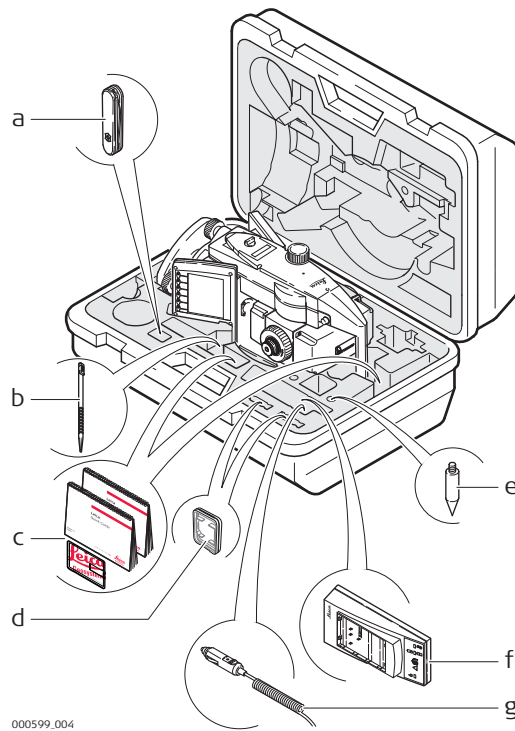

000599.004

- a) Pocket knife*
 - b) Spare stylus
 - c) Manuals & USB documentation card
 - d) SD cards/CompactFlash cards and covers
 - e) Tip for mini prism
 - f) Battery charger
 - g) Car adapter power plug for battery charger (stored under battery charger)
- * Optional

**Container for TPS
robotic pole setup,
small size**

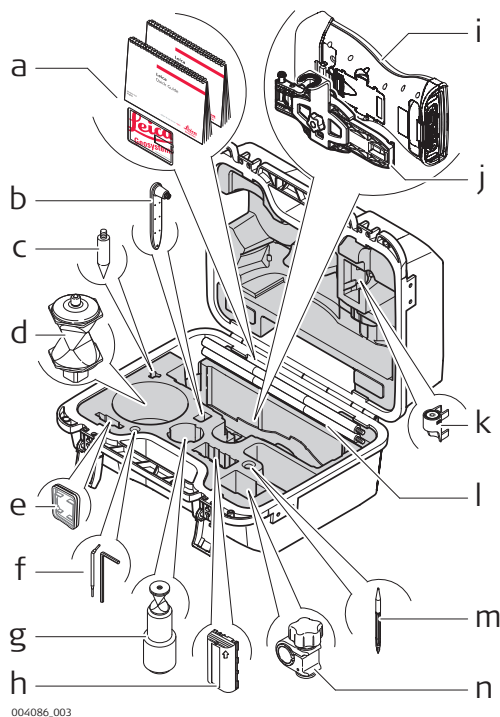

- a) Manuals & USB documentation card
- b) GAT21 radio antenna
- c) Tip for mini pole
- d) GRZ4/GRZ122 prism
- e) CompactFlash card/SD card
- f) Adjustment tool and allen key
- g) GRZ101 mini prism and GAD103 adapter
- h) GEB212 battery
- i) Field controller with CTR
- j) GHT62 holder (extended)
- k) GLI115, clip-on bubble for mini pole
- l) GLS115 mini pole
- m) Spare stylus
- n) GHT63 clamp

2.4

Instrument Components

Instrument components part 1 of 2

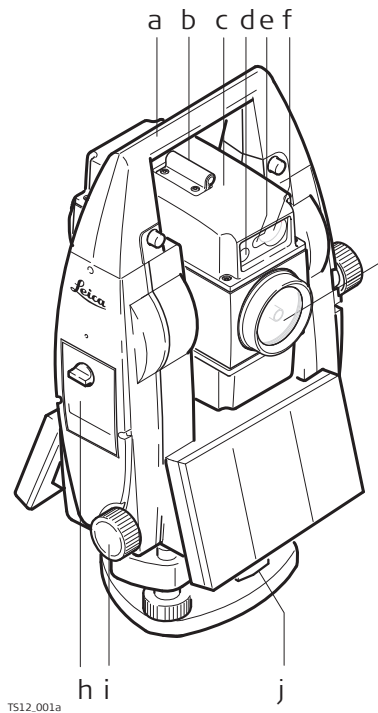

- a) Carry handle
- b) Optical sight
- c) Telescope, integrating EDM, ATR, EGL, PS
- d) EGL flashing diode - yellow and red
- e) PowerSearch, transmitter
- f) PowerSearch, receiver
- g) Coaxial optics for angle and distance measurement, and exit port of visible laser beam for distance measurements
- h) CompactFlash card compartment
- i) Horizontal drive
- j) Tribrach securing screw

Instrument components part 2 of 2

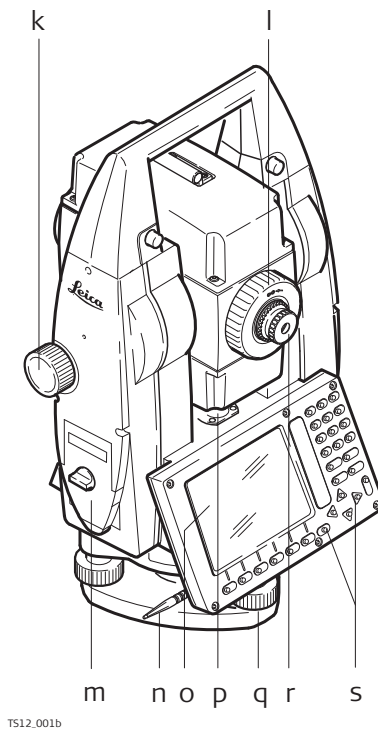

- k) Vertical drive
- l) Focusing ring
- m) Battery compartment
- n) Stylus for touch screen
- o) Screen
- p) Circular level
- q) Tribrach footscrew
- r) Eyepiece
- s) Keyboard

Instrument components for RCS

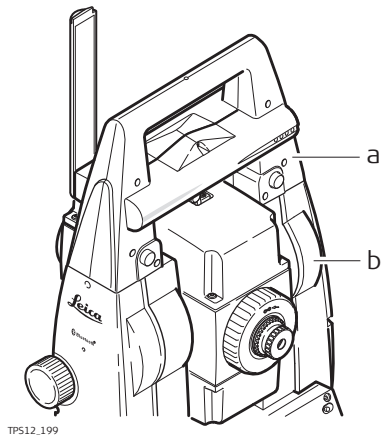

- a) RadioHandle
 - b) Communication side cover
-

3 User Interface

3.1 Keyboard

Keyboard

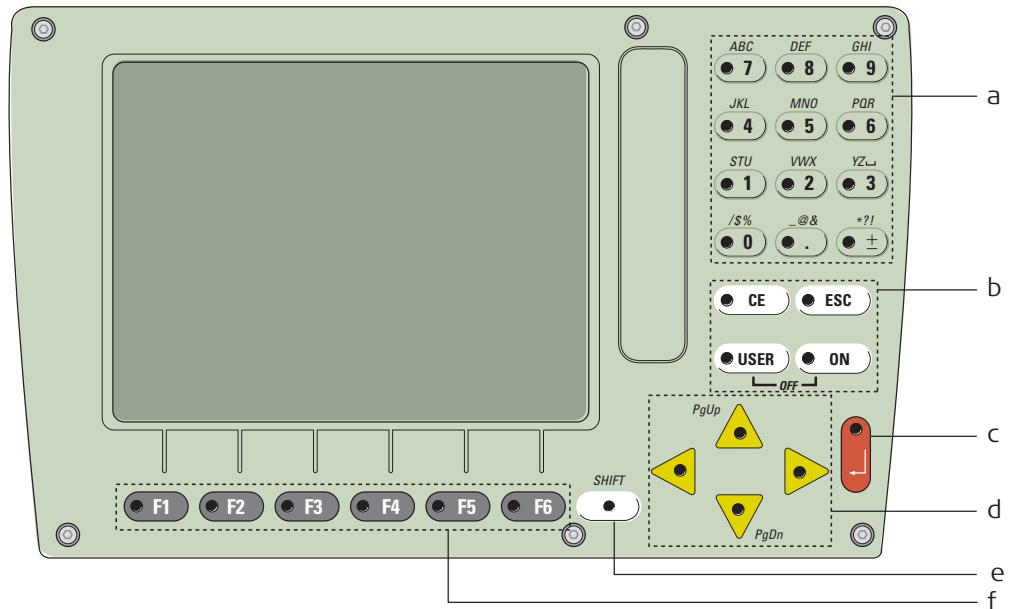

- TS12_070
- a) Alphanumeric keys
 - b) CE, ESC, USER, ON
 - c) ENTER

- d) Arrow keys
- e) SHIFT
- f) Function keys F1-F6

Keys

Key	Description
Alphanumeric keys	<ul style="list-style-type: none"> To type letters and numbers.
CE	<ul style="list-style-type: none"> Clears all entry at the beginning of user input. Clears the last character during user input.
ESC	<ul style="list-style-type: none"> Leaves the current menu or dialog without storing changes made.
USER	<ul style="list-style-type: none"> Calls the user-defined menu.
ON	<ul style="list-style-type: none"> If the instrument is off: to turn instrument on.
ENTER	<ul style="list-style-type: none"> Selects the highlighted line and leads to the next logical dialog/menu. Starts the edit mode for edit fields. Opens a list box.
SHIFT	<ul style="list-style-type: none"> Changes between the first and the second level of function keys.
Arrow keys	<ul style="list-style-type: none"> Move the focus on the screen.
Function keys F1-F6	<ul style="list-style-type: none"> Correspond to the six softkeys that appear on the bottom of the screen when the screen is activated.

Key combinations

Keys	Description
ON plus USER	Turns instrument off.
SHIFT ▲	Pages up.
SHIFT ▼	Pages down.

Screen

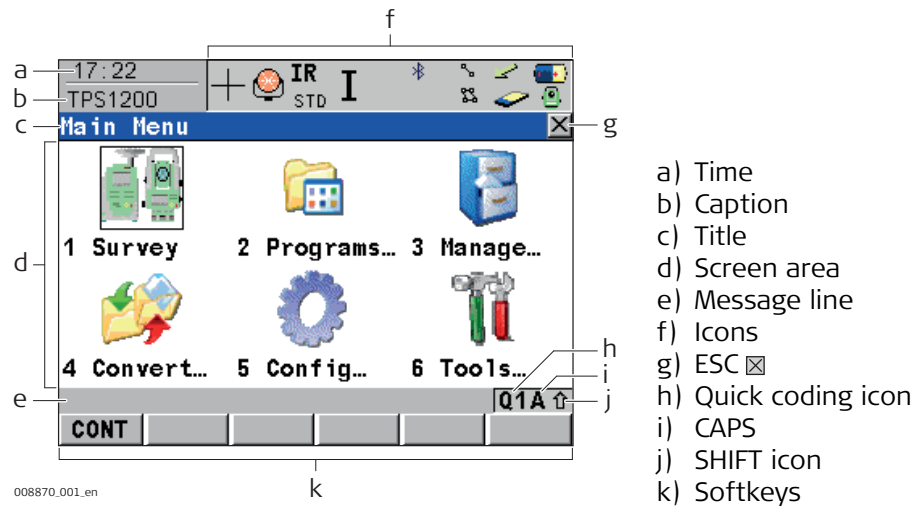

Elements of the screen

Element	Description
Time	The current local time is shown.
Caption	Shows location e.g. Main Menu .
Title	Name of the screen is shown.
Screen area	The working area of the screen.
Message line	Messages are shown for 10 s.
Icons	Shows current status information of the instrument. Refer to "3.4 Icons". Can be used with touch screen.
ESC 	Can be used with touch screen. Same functionality as the fixed key ESC. The last operation will be undone.
CAPS	The caps mode for upper case letters is active. The caps mode is activated and deactivated by pressing UPPER (F5) or LOWER (F5) in some screens.
SHIFT icon	Shows the status of the SHIFT key; either first or second level of softkeys is selected. Can be used with touch screen and has the same functionality as the fixed key SHIFT.
Softkeys	Commands can be executed using (F1)-(F6) keys. The commands assigned to the softkeys are screen-dependent. Can be used directly with touch screen.
Scroll bar	Scrolls the screen area up and down.

3.3

Operating Principles

Keyboard and touch screen

The user interface is operated either by the keyboard or by the touch screen with supplied stylus. The workflow is the same for keyboard and touch screen entry, the only difference lies in the way information is selected and entered.

Turn instrument on

Press and hold ON for 2 s.

Turn instrument off step-by-step

Step	Description
	The instrument can only be turned off in the Main Menu .
1.	Press and hold both USER and ON simultaneously. OR Press ESC for more than 2 s.
2.	Press YES (F6) to continue or NO (F4) to cancel.

Lock/Unlock keyboard

Option	Description
Lock	To lock the keyboard press and hold SHIFT for 3 s. The message 'Keyboard locked' is momentarily displayed on the Message Line.
Unlock	To unlock the keyboard press and hold SHIFT for 3 s. The message 'Keyboard unlocked' is momentarily displayed on the Message Line.

Selecting from a menu

Appearance	Description
	To select an item from a menu, do one of the following: Move the focus to the item. ENTER or CONT (F1). OR Type the complete selection number in front of the item. ENTER or CONT (F1) are not required. OR Tap on the item with the stylus.

Selecting a page

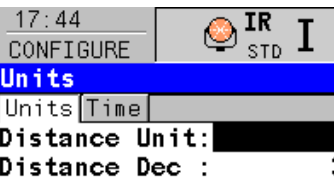
Appearance	Description
	To select a page in a screen, do one of the following: PAGE (F6). OR Tap on the page tab with the stylus.

Edit an entire value in input fields

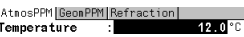
Appearance	Description
	1) Highlight the field. 2) Type numeric and/or alphanumeric characters to overwrite. 3) ENTER or tap outside of the field.

Edit an individual character in input fields

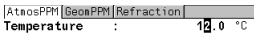
Appearance	Description
	<p>A character can be inserted or overwritten. The procedure is the same for both cases.</p> <ol style="list-style-type: none"> 1) Highlight the field. 2) For the keyboard: ENTER. The edit mode is activated where additional functions like insert and overwrite are available. For the touch screen: Highlight the characters to be changed. 3) Type numeric and/or alphanumeric characters. 4) ENTER or tap outside of the field.

Access special alphanumeric characters for input

Step	Description
1.	Highlight the input field.
2.	For the keyboard: ENTER.
3.	Toggle to the desired special character set by using the up/down arrow keys.
4.	Press the function key assigned to the required character group.
5.	Press the function key with the required character.
6.	Repeat step 4. and 5. for entering more special characters of the same character set.
7.	ENTER.

Appearance and selection from a choicelist

Choicelists have various appearances.

Closed choicelist

Appearance	Description	Selection
	Triangles on the right indicate further available choices.	Use the arrow keys ◀ ▶ to change through the list or tap the triangles on the screen.

ENTER or tap on the field to access the choicelist. Opening a choicelist reveals either a simple listbox or a comprehensive listbox dialog.

Simple listbox

Appearance	Description	Selection
	<ul style="list-style-type: none"> • Choicelist shows items to select. • A search field is shown if necessary. • A scroll bar is shown if necessary. 	<ul style="list-style-type: none"> • Highlight the item and ENTER. • To exit without changes ESC, tap ☒ or outside the simple listbox.

Listbox dialog

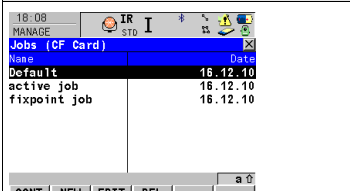
Appearance	Description	Selection
	<ul style="list-style-type: none"> • Choicelist fills the whole screen. • A search field is shown. • A scroll bar is shown if necessary. • The functionality comprises adding, editing and deleting of items. • Listbox dialogs are explained in detail at appropriate places in the manuals. 	<ul style="list-style-type: none"> • Highlight the item and CONT (F1). • To exit without changes press ESC or tap ☒.

Description

The screen icons display the status information of the instrument.

Position of the icons on the screen

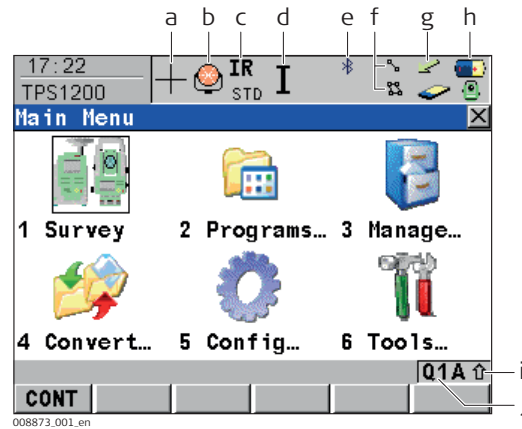

- a) ATR/LOCK/PS
- b) Reflector
- c) EDM
- d) Compensator/face I&II
- e) Bluetooth
- f) Line/area
- g) CompactFlash card
- h) Battery
- i) SHIFT
- j) Quick coding

Icons

Icon	Description
ATR/LOCK/PS	The currently active ATR/LOCK/PS settings or searches are displayed.
Reflector	The currently active reflector is displayed.
EDM	The currently active EDM measurement settings are displayed.
Compensator/face I&II	Compensator off, out of range or face I&II icon is displayed.
Bluetooth	The status of each Bluetooth port and any bluetooth connection is displayed.
Line/area	The number of lines and areas currently open in the active job is displayed.
CompactFlash card	For the CompactFlash card, the capacity of used space is shown in seven levels.
Battery	The status and source of the battery is displayed. The percentage of remaining power capacity for all batteries is displayed numerically and graphically. For internal and external battery being attached at the same time the internal battery is used until it is empty and then the external battery is used.
SHIFT	The status of the SHIFT key is displayed.
Quick coding	Shows the quick coding configuration. Can be used with touch screen to turn quick coding on and off.

4

Operation

4.1

Instrument Setup

Description

This topic describes an instrument setup over a marked ground point using the laser plummet. It is always possible to set up the instrument without the need for a marked ground point.



Important features

- It is always recommended to shield the instrument from direct sunlight and avoid uneven temperatures around the instrument.
- The laser plummet described in this topic is built into the vertical axis of the instrument. It projects a red spot onto the ground, making it appreciably easier to centre the instrument.
- The laser plummet cannot be used with a tribrach equipped with an optical plummet.

Setup step-by-step

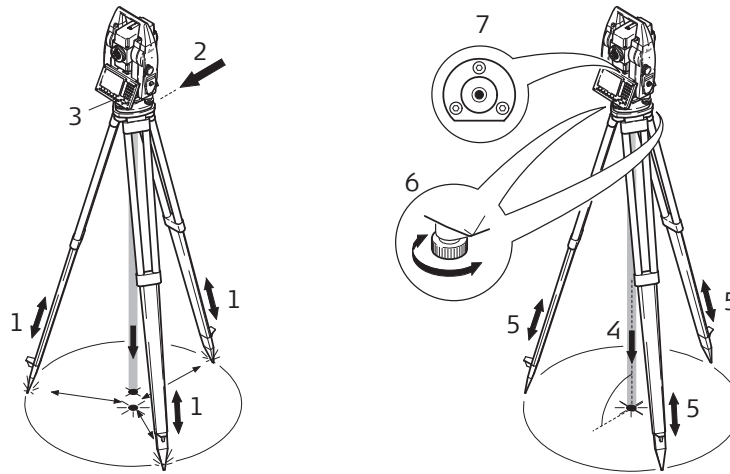

TS12.019

Step	Description
	Shield the instrument from direct sunlight and avoid uneven temperatures around the instrument.
1.	Extend the tripod legs to allow for a comfortable working posture. Position the tripod over the marked ground point, centring it as well as possible.
2.	Fasten the tribrach and instrument onto the tripod.
3.	Turn on the instrument by pressing ON for 2 s. Press USER, STAT (F3) to access the Status Menu . Select Level & Laser Plummet to access STATUS Level & Laser Plummet , activating the laser plummet.
4.	Move the tripod legs (1) and use the tribrach footscrews (6) to centre the plummet (4) over the ground point.
5.	Adjust the tripod legs to level the circular level (7).
6.	By using the electronic level turn the tribrach footscrews (6) to precisely level the instrument.
7.	Centre the instrument precisely over the ground point (4) by shifting the tribrach on the tripod plate (2).
8.	Repeat steps 6. and 7. until the required accuracy is achieved.

4.2

Setting Up SmartPole

SmartPole setup using GS15/GS14

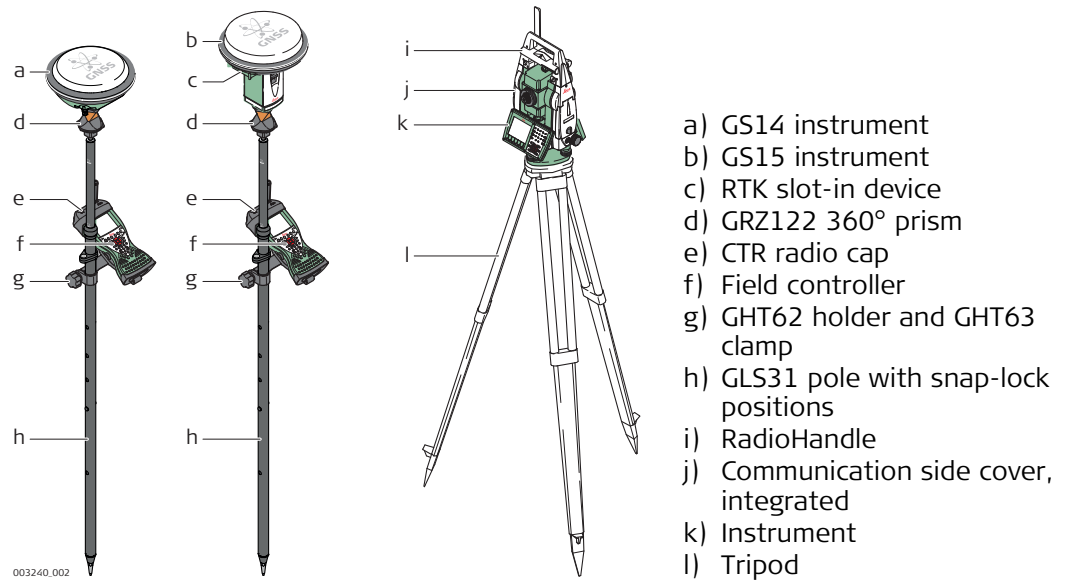

4.3

Setting up for Remote Control (with the RadioHandle)

Setup for remote control with RadioHandle

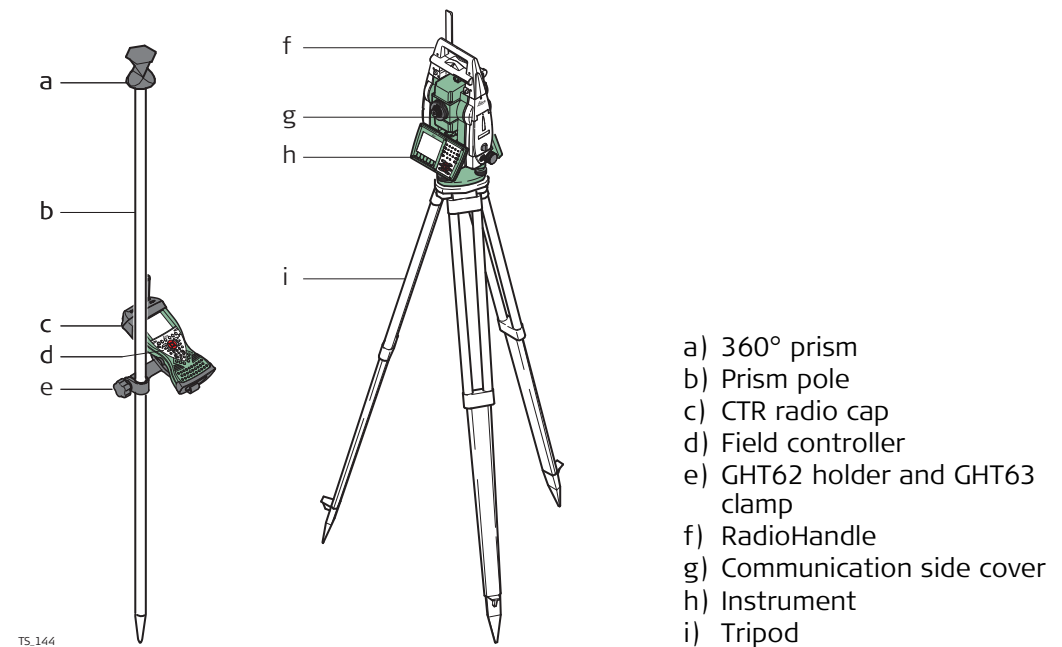

Components of the GHT62 holder

The GHT62 holder consists of some components, as shown in the diagram.

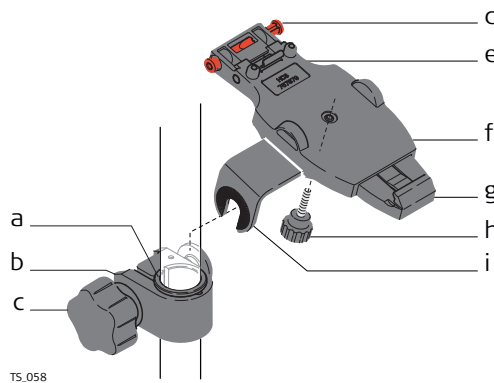

GHT63 clamp

- a) Plastic sleeve
- b) Pole clamp
- c) Clamp bolt

GHT62 holder

- d) Locking pin
- e) Top clip
- f) Mounting plate (extendable)
- g) Bottom clip
- h) Tightening screw
- i) Mounting arm

Fixing the field controller and GHT62 to a pole step by step

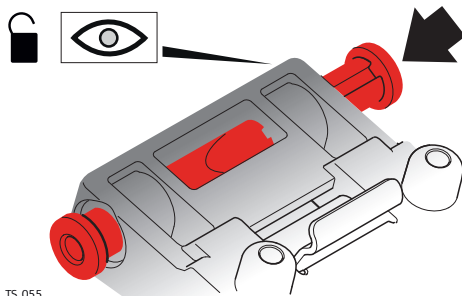
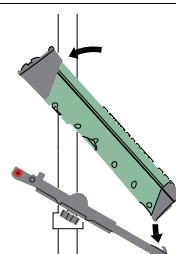
Step	Description
	If you use the CS15 field controller, extend the mounting plate of the holder first.
	For an aluminium pole, fit the plastic sleeve to the pole clamp.
1.	Insert the pole into the clamp hole.
2.	Attach the holder to the clamp using the clamp bolt.
3.	Adjust the angle and the height of the holder on the pole to a comfortable position.
4.	Tighten the clamp with the clamp bolt.
5.	Before the field controller is placed onto the mounting plate, ensure that the locking pin is put into the unlocked position. To unlock the locking pin, push the locking pin to the left. 
6.	Hold the field controller above the holder and lower the end of the field controller into the mounting plate.
7.	Apply slight pressure in a downward direction and then lower the top part of the field controller until the unit is clicked into the holder. The guides of the mounting plate aid in this action. 

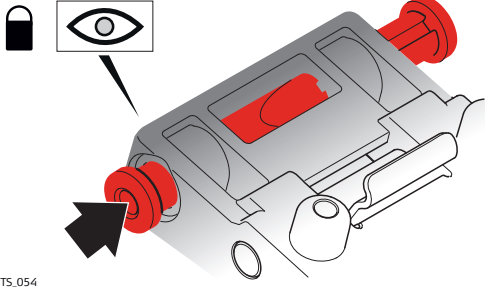
Step	Description
8.	<p>After the field controller is placed onto the mounting plate, ensure that the locking pin is put into the locked position. To lock the locking pin, push the locking pin to the right.</p>  <p style="text-align: right; font-size: small;">TS_054</p>

Detaching the field controller from a pole step by step

Step	Description
1.	Unlock the locking pin by pushing the locking pin to the left of the mounting plate.
2.	Place palm over the top of the field controller until fingers grip the bar of the holder underneath.
3.	Push from the top of the field controller toward the bar of the holder.
4.	While in this position, lift the top of the field controller from the holder.

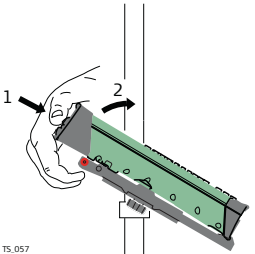

TS_057

4.5

Autodetect Behaviour

Description

- The instrument incorporates an autodetect behaviour and automatically detects the following device:
 - RadioHandle
- Whenever a device is attached, the instrument responds with two short beeps.
- Whenever a device is removed, the instrument responds with one long beep.

RadioHandle

- RadioHandle is automatically detected by the instrument when it is attached.
- When RadioHandle is attached, the appropriate port and device settings have to be set manually in the **CONFIGURE Interfaces** menu.

4.6

Instrument Setup for Remote Control

4.6.1

Remote Control Setup

Setup step by step

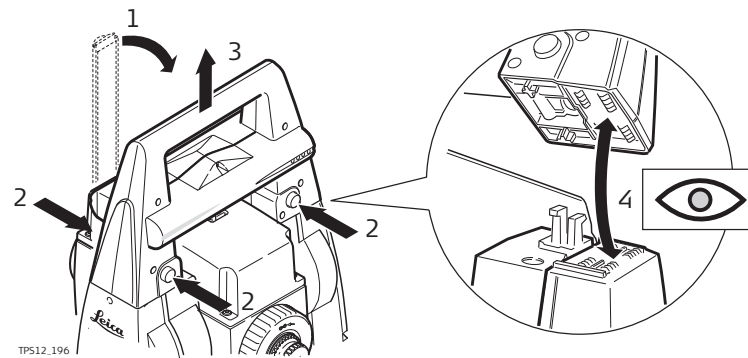

Step	Description
	Refer to "4.1 Instrument Setup" for the initial instrument setup onto a tripod. Remove the instrument carry handle by simultaneously pressing and holding-in the four push buttons.
1.	Place the RadioHandle onto the instrument by simultaneously pressing and holding-in the four push buttons.
	Ensure that the interface connection on the underside of the RadioHandle is on the same side as the Communication side cover.
2.	Swing the RadioHandle antenna into an upright position.
	Refer to "CS15 User Manual" for additional information.

LED Indicators**Description**

The RadioHandle has **L**ight **E**mitting **D**iode indicators. They indicate the basic RadioHandle status.

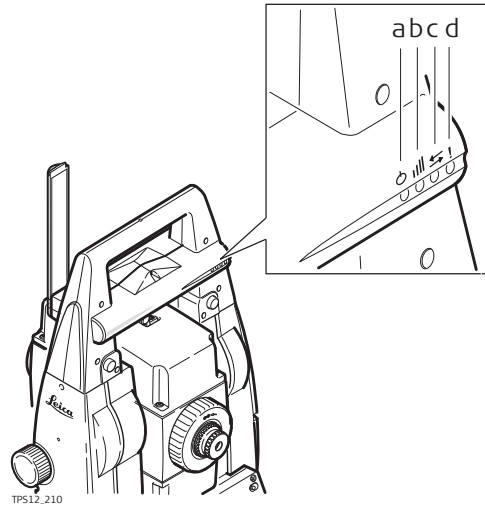
Diagram of the LED Indicators

- a) Power LED
- b) Link LED
- c) Data Transfer LED
- d) Mode LED

Description of the LED Indicators

IF the	is	THEN
Power LED	off	power is off.
	green	power is on.
Link LED	off	no radio link to remote controller.
	red	radio link to remote controller.
Data Transfer LED	off	no data transfer to/from remote controller.
	green or green flashing	data transfer to/from remote controller.
Mode LED	off	data mode.
	red	configuration mode.

4.7

Batteries

4.7.1

Operating Principles

First-time Use / Charging Batteries

- The battery must be charged prior to using it for the first time.
- The permissible temperature range for charging is between 0°C to +40°C/ +32°F to +104°F. For optimal charging, we recommend charging the batteries at a low ambient temperature of +10°C to +20°C/+50°F to +68°F if possible.
- It is normal for the battery to become warm during charging. Using the chargers recommended by Leica Geosystems, it is not possible to charge the battery if the temperature is too high.
- For Li-Ion batteries, a single refreshing cycle is sufficient. We recommend carrying out a refreshing cycle when the battery capacity indicated on the charger or on a Leica Geosystems product deviates significantly from the actual battery capacity available.

Operation / Discharging

- The batteries can be operated from -20°C to +55°C/-4°F to +131°F.
- Low operating temperatures reduce the capacity that can be drawn; high operating temperatures reduce the service life of the battery.

4.7.2

Instrument Battery

Change battery step by step

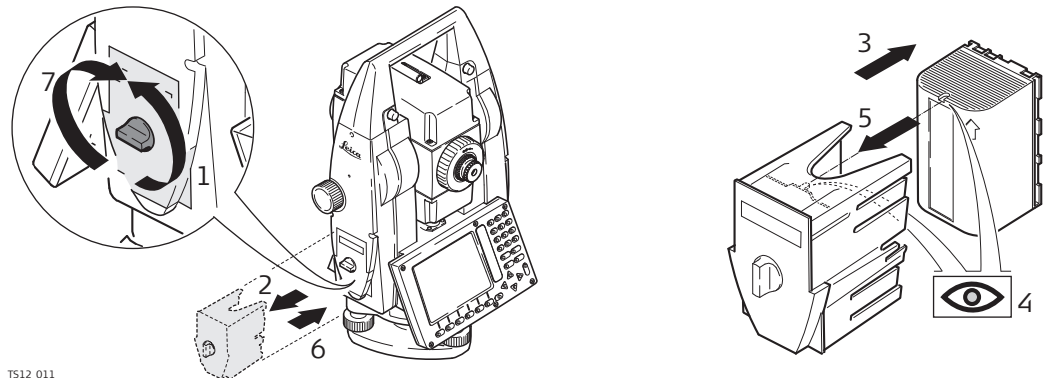

TS12_011

Step	Description
1.	Face the instrument so that the vertical drive screw is on the left. The battery compartment is now on the left side of the instrument. Turn the knob to the vertical position, opening the lid of the battery compartment.
2.	Pull out the battery housing.
3.	Pull the battery from the battery housing.
4.	A pictogram of the battery is displayed inside the battery housing. This is a visual aid to assist in placing the battery correctly.
5.	Place the battery into the battery housing, ensuring that the contacts are facing outward. Click the battery into position.
6.	Place the battery housing into the battery compartment. Push the battery housing in until it fits completely into the battery compartment.
7.	Turn the knob to lock the battery compartment. Ensure that the knob is returned to its original horizontal position.



- Keep the card dry.
- Use it only within the specified temperature range.
- Do not bend the card.
- Protect the card from direct impacts.



Failure to follow these instructions could result in data loss and/or permanent damage to the card.

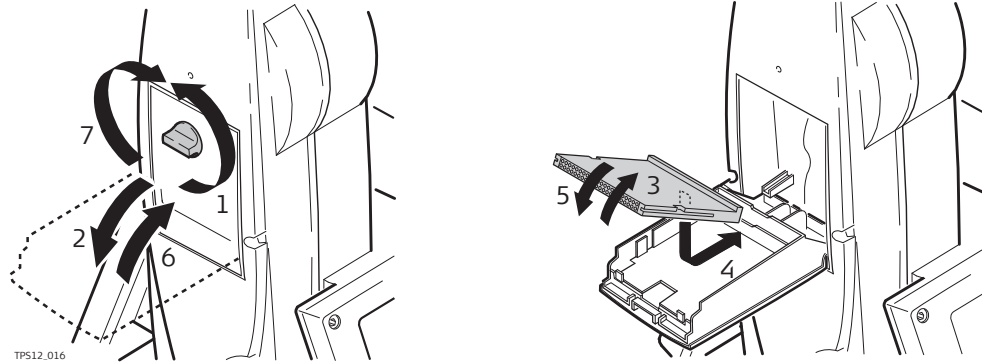

Insert and remove a CompactFlash card step by step



Step	Description
1.	Face the instrument so that the vertical drive screw is on the left. The CompactFlash card compartment is now on the right side of the instrument. Turn the knob to the vertical position, opening the lid of the CompactFlash card compartment.
2.	Open the lid of the CompactFlash card compartment.
3.	Pull the front of the CompactFlash card up and take the card out of the lid.
4.	Place the lower end of the CompactFlash card at the lower end of the CompactFlash card compartment. The extended edge of the card has to be on the upper side as shown on the pictogram in the CompactFlash card compartment.
5.	Press the card down on the lid.
6.	Close the lid.
7.	Turn the knob to lock the CompactFlash card compartment. The lid is closed correctly when the knob is turned to a horizontal position.

Format a CompactFlash card step by step

Formatting the CompactFlash card before starting to store data is required if a completely new CompactFlash card is used or if all existing data needs to be deleted.

Step	Description
1.	Main Menu: Tools... \Format Memory Device.
2.	TOOLS Format Memory Device <Memory Device: CF Card> <Format Method: Format Quick> Select the memory device to be formatted.
	By activating the format command all data will be lost. Make sure that all important data on the CompactFlash card has been backed up before formatting the card. Before formatting the internal memory make sure that all important data is first transferred to the PC.
	To exit the screen without formatting the memory device, press ESC. This returns to the previous screen without execution of any command.
3.	CONT (F1).
4.	YES (F4) to complete the formatting of the CompactFlash card.
	NO (F6) to abort the formatting of the CompactFlash card and return to TOOLS Format Memory Device.
5.	Once the formatting of the CompactFlash card is completed the system returns to the Main Menu.

4.9

Guidelines for Correct Results



Very short distances may be measured reflectorless in IR mode to well reflecting targets. Note that the distances are corrected with the additive constant defined for the active reflector.

Distance measurement

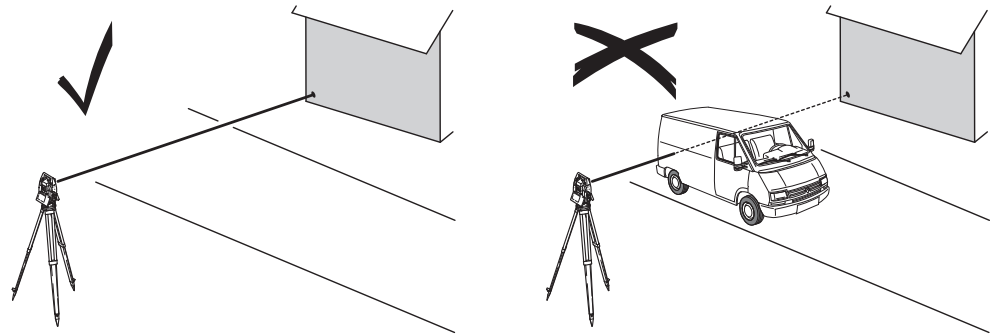

When measurements are being made using the red laser EDM, the results can be influenced by objects passing between the EDM and the intended target surface. This occurs because reflectorless measurements are made to the first surface returning sufficient energy to allow the measurement to take place. For example, if the intended target surface is the surface of a building, but a vehicle passes between the EDM and the target surface as the measurement is triggered from a field controller, the measurement may be made to the side of the vehicle. The result is the distance to the vehicle, not to the surface of the building.

If using the long range measurement mode (> 1000 m, > 3300 ft) to prisms, and an object passes within 30 m of the EDM as the measurement is triggered, the distance measurement may be similarly effected due to the strength of the laser signal.



CAUTION

Due to laser safety regulations and measuring accuracy, using the Long Range Reflectorless EDM is only allowed to prisms that are more than 1000 m (3300 ft) away.



Accurate measurements to prisms should be made in IR mode.



When a distance measurement is triggered, the EDM measures to the object which is in the beam path at that moment. If a temporary obstruction, for example a passing vehicle, heavy rain, fog or snow is between the instrument and the point to be measured, the EDM may measure to the obstruction.



Do not measure with two instruments to the same target simultaneously to avoid getting mixed return signals.

ATR/lock

Instruments equipped with an ATR sensor permit automatic angle measurements to prisms. The prism is sighted with the optical sight. After initiating a distance measurement, the instrument sights the prism centre automatically. Vertical and horizontal angles and the distance are measured to the centre of the prism. The lock mode enables the instrument to follow a moving prism.



As with all other instrument errors, the collimation error of the automatic aiming must be redetermined periodically. Refer to "5 Check & Adjust" about checking and adjusting instruments.



When a measurement is triggered from the CS field controller while the prism is still moving, distance and angle measurements may not be made for the same position and coordinates may vary.



If the prism location is changed too quickly, the target may be lost. Make sure that the speed does not exceed the figure given in the technical data.

5

Check & Adjust

5.1

Overview

Description	<p>Leica Geosystems instruments are manufactured, assembled and adjusted to the best possible quality. Quick temperature changes, shock or stress can cause deviations and decrease the instrument accuracy. It is therefore recommended to check and adjust the instrument from time to time. This check and adjust can be done in the field by running through specific measurement procedures. The procedures are guided and must be followed carefully and precisely as described in the following chapters. Some other instrument errors and mechanical parts can be adjusted mechanically.</p>										
Electronic adjustment	<p>The following instrument errors can be checked and adjusted electronically:</p> <table><tr><td>l, t</td><td>Compensator longitudinal and transversal index errors</td></tr><tr><td>i</td><td>Vertical index error, related to the standing axis</td></tr><tr><td>c</td><td>Horizontal collimation error, also called line of sight error</td></tr><tr><td>a</td><td>Tilting axis error</td></tr><tr><td>ATR</td><td>ATR zero point error for Hz and V - option</td></tr></table> <p>Every angle measured in the daily work is corrected automatically if the compensator and the Hz-corrections are activated in the instrument configuration. Select Main Menu: Config...\Instrument Settings...\Compensator to check the settings.</p>	l, t	Compensator longitudinal and transversal index errors	i	Vertical index error, related to the standing axis	c	Horizontal collimation error, also called line of sight error	a	Tilting axis error	ATR	ATR zero point error for Hz and V - option
l, t	Compensator longitudinal and transversal index errors										
i	Vertical index error, related to the standing axis										
c	Horizontal collimation error, also called line of sight error										
a	Tilting axis error										
ATR	ATR zero point error for Hz and V - option										
View current adjustment errors	<p>The currently used adjustment errors can be viewed under Main Menu: Tools...\Check & Adjust...\Current Values.</p>										
Mechanical Adjustment	<p>The following instrument parts can be adjusted mechanically:</p> <ul style="list-style-type: none">• Circular level on instrument and tribrach• Optical plummet - option on tribrach• Allen screws on tripod										
Precise Measurements	<p>To get precise measurements in the daily work, it is important:</p> <ul style="list-style-type: none">• To check and adjust the instrument from time to time.• To take high precision measurements during the check and adjust procedures.• To measure targets in two faces. Some of the instrument errors are eliminated by averaging the angles from both faces.										
	<p>During the manufacturing process, the instrument errors are carefully determined and set to zero. As mentioned above, these errors can change and it is highly recommended to redetermine them in the following situations:</p> <ul style="list-style-type: none">• Before the first use• Before every high precision survey• After rough or long transportation• After long working periods• After long storage periods• If the temperature difference between current environment and the temperature at the last calibration is more than 20°C										

Summary of errors to be adjusted electronically

Instrument error	Effects Hz	Effects V	Elimination with two face measurement	Automatically corrected with proper adjustment
c - Line of sight error	✓	-	✓	✓
a - Tilting axis error	✓	-	✓	✓
l - Compensator index error	-	✓	✓	✓
t - Compensator index error	✓	-	✓	✓
i - Vertical index error	-	✓	✓	✓
ATR Collimation error	✓	✓	-	✓

5.2

Preparation



Before determining the instrument errors, the instrument has to be levelled using the electronic level. Press **USER, STAT (F3)** to access the **Status Menu**. Select **Level & Laser Plummet** to access **STATUS Level & Laser Plummet, Level** page.

The tribrach, the tripod and the underground should be stable and secure from vibrations or other disturbances.



The instrument should be protected from direct sunlight to avoid thermal warming.

It is also recommended to avoid strong heat shimmer and air turbulence. The best conditions are early in the morning or with overcast sky.



Before starting to work, the instrument has to become acclimatised to the ambient temperature. Approximately two minutes per °C of temperature difference from storage to working environment, but at least 15 min, should be taken into account.



Even after adjustment of the ATR, the crosshairs may not be positioned exactly on the centre of the prism after an ATR measurement has been completed. This outcome is a normal effect. To speed up the ATR measurement, the telescope is normally not positioned exactly on the centre of the prism. These small deviations/ATR offsets, are calculated individually for each measurement and corrected electronically. This means that the horizontal and vertical angles are corrected twice: first by the determined ATR errors for Hz and V, and then by the individual small deviations of the current aiming.

Next Step

IF the task is to	THEN
adjust a combination of instrument errors	Refer to "5.3 Combined Adjustment (l, t, i, c and ATR)".
adjust the tilting axis	Refer to "5.4 Tilting Axis Adjustment (a)".
adjust the circular level	Refer to "5.5 Adjusting the Circular Level of the Instrument and Tribrach".
adjust the laser/optical plummet	Refer to "5.7 Inspecting the Laser Plummet of the Instrument".
adjust the tripod	Refer to "5.8 Servicing the Tripod".

5.3

Combined Adjustment (I, t, i, c and ATR)



Description

The combined adjustment procedure determines the following instrument errors in one process:

I, t	Compensator longitudinal and transversal index errors
i	Vertical index error, related to the standing axis
c	Horizontal collimation error, also called line of sight error
ATR Hz	ATR zero point error for horizontal angle option
ATR V	ATR zero point error for vertical angle option

Combined adjustment procedure step by step

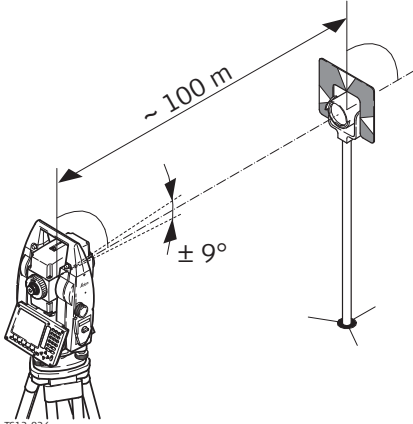
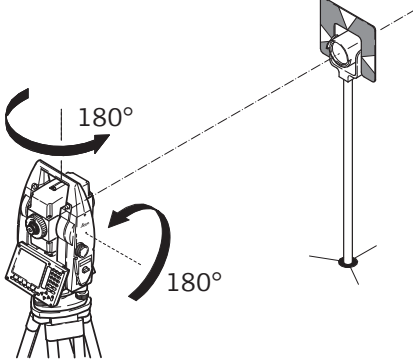
The following table explains the most common settings.

Step	Description
1.	Main Menu: Tools... \Check & Adjust...
2.	TOOLS Check & Adjust Menu Select the option: Combined (I,t,i,c,ATR)
3.	TOOLS Combined I <ATR Adjust: On> Includes the determination of the ATR Hz and V adjustment errors if an ATR is available.  It is recommended to use a clean Leica circular prism as target. Do not use a 360° prism.
4.	 Aim the telescope accurately at a target at about 100 m distant. The target must be positioned within $\pm 9^\circ / \pm 10$ gon of the horizontal plane. The procedure can be started in any telescope face. <small>TS12_024</small>
5.	MEAS (F1) to measure and to continue to the next screen.  Motorised instruments change automatically to the other face.  The fine pointing has to be performed manually. <small>TS12_025</small>
6.	TOOLS Combined II MEAS (F1) to measure the same target in the other face and to calculate the instrument errors.  If one or more errors are bigger than the predefined limits, the procedure has to be repeated. All measurements of the current run are rejected and none of them is averaged with the results from previous runs.

Step	Description
7.	<p>TOOLS Adjustment Accuracy</p> <p><No.of Meas:> Shows the number of runs executed. One run consists of a measurement in face I and face II.</p> <p><σ I Comp:> and similar lines show the standard deviations of the determined adjustment errors. The standard deviations can be calculated from the second run onwards.</p>
	It is recommended to measure at least two runs.
8.	<p>MEAS (F5) if more runs have to be added. Continue with step 3.</p> <p>OR</p> <p>CONT (F1) to accept the measurements and to proceed to TOOLS Adjustment Results. No more runs can be added later.</p>

Next step

IF the results are	THEN
to be stored	CONT (F1) overwrites the old adjustment errors with the new ones, if the Use status is set to Yes .
to be determined again	REDO (F2) rejects all new determined adjustment errors and repeats the whole procedure. Refer to step 3. of paragraph "Combined adjustment procedure step by step".

5.4

Tilting Axis Adjustment (a)



Description

This adjustment procedure determines the following instrument error:

a Tilting axis error

Determination of tilting axis error step by step

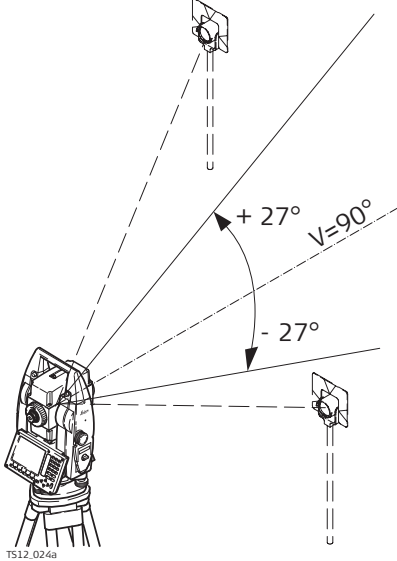
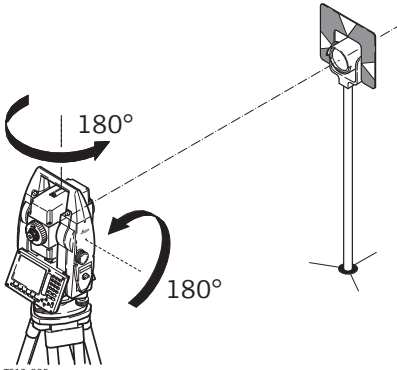
The following table explains the most common settings.

Step	Description
	The Hz collimation error (c) has to be determined before starting this procedure.
1.	Main Menu: Tools... \Check & Adjust...
2.	TOOLS Check & Adjust Menu Select the option: Tilting Axis (a)
3.	<p>TOOLS Tilting-Axis Adjustment I</p>  <p>Aim the telescope accurately at a target at about 100 m distance or less if not possible. The target must be positioned at least 27°/30 gon above or beneath the horizontal plane. The procedure can be started in any telescope face.</p>
4.	<p>MEAS (F1) to measure and to continue to the next screen.</p>  <p>Motorised instruments change automatically to the other face.  The fine pointing has to be performed manually.</p>
5.	<p>TOOLS Tilting-Axis Adjustment II</p> <p>MEAS (F1) to measure the same target in the other face and to calculate the tilting axis error.</p>
	If the error is bigger than the predefined limit, the procedure has to be repeated. The tilting axis measurements of the current run are then rejected and not averaged with the results from previous runs.

Step	Description
6.	<p>TOOLS T-Axis Adjustment Accuracy</p> <p><No.of Meas:> Shows the number of runs executed. One run consists of a measurement in face I and face II.</p> <p><σ a T-axis:> shows the standard deviation of the determined tilting axis error. The standard deviation can be calculated from the second run onwards.</p>
	It is recommended to measure at least two runs.
7.	<p>MEAS (F5) if more runs have to be added. Continue with step 3.</p> <p>OR</p> <p>CONT (F1) to accept the measurements and to proceed to TOOLS T-Axis Adjustment Result. No more runs can be added later.</p>

Next step

IF the results are	THEN
to be stored	CONT (F1) overwrites the old adjustment errors with the new ones, if the Use status is set to Yes .
to be determined again	REDO (F2) rejects all new determined adjustment errors and repeats the whole procedure. Refer to step 3. of paragraph "Determination of tilting axis error step by step".

5.5

Adjusting the Circular Level of the Instrument and Tribrach

Adjusting the circular level step by step

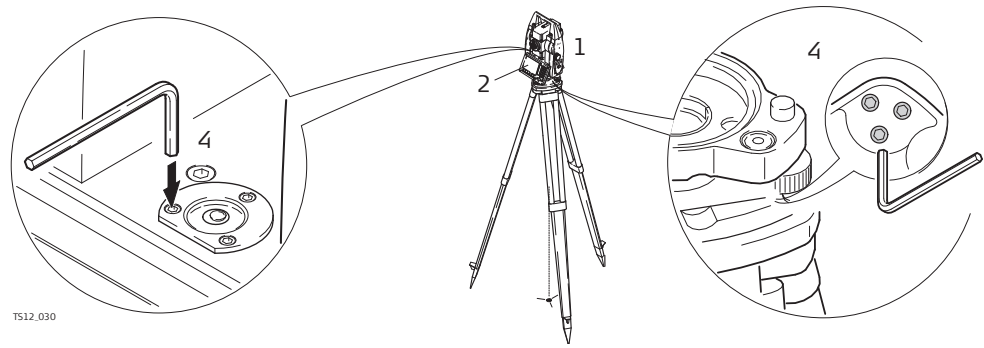

TS12_030

Step	Description
1.	Place and secure the instrument into the tribrach and onto a tripod.
2.	Using the tribrach footscrews, level the instrument with the electronic level. Press USER, STAT (F3) to access the Status Menu . Select Level & Laser Plummet to access STATUS Level & Laser Plummet .
3.	Check the position of the circular level on the instrument and tribrach.
4.	<p>a) If both circular levels are centered, no adjustments are necessary.</p> <p>b) If one or both circular levels are not centered, adjust as follows:</p> <p>Instrument: If it extends beyond the circle, use the supplied allen key to centre it with the adjustment screws. Turn the instrument by 200 gon (180°). Repeat the adjustment procedure if the circular level does not stay centered.</p> <p>Tribrach: If it extends beyond the circle, use the supplied allen key to centre it with the adjustment screws.</p>
	After the adjustments, all adjusting screws should have the same tightening tension and no adjusting screw shall be loose.

5.6

Adjusting the Circular Level of the Prism Pole

Adjusting the Circular Level Step by Step

Step	Description
1.	Suspend a plumb line.
2.	Use a pole bipod, to align the prism pole parallel to the plumb line.
3.	Check the position of the circular level on the prism pole.
4.	<p>a) If the circular level is centred, no adjustment is necessary.</p> <p>b) If the circular level is not centred, use an allen key to centre it with the adjustment screws.</p>
	After the adjustments, all adjusting screws must have the same tightening tension and no adjusting screw should be loose.

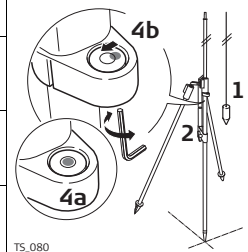

TS_080

5.7

Inspecting the Laser Plummet of the Instrument



The laser plummet is located in the vertical axis of the instrument. Under normal conditions of use, the laser plummet does not need adjusting. If an adjustment is necessary due to external influences, return the instrument to any Leica Geosystems authorised service workshop.

Inspecting the laser plummet step by step

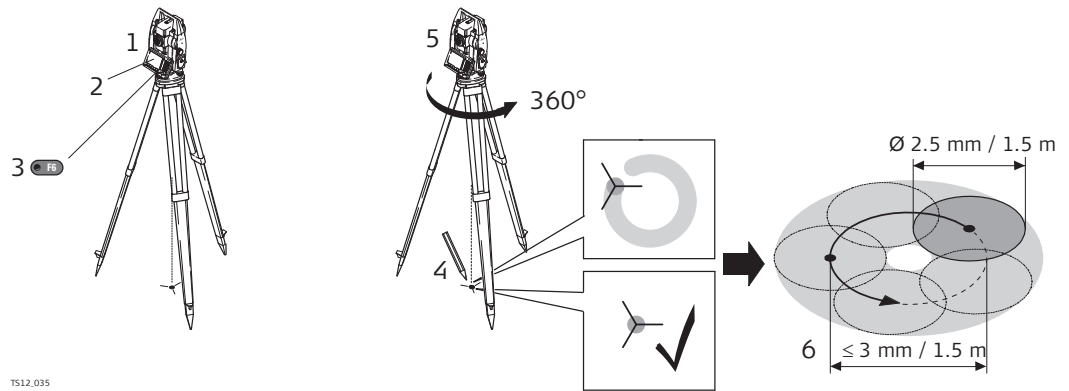

The following table explains the most common settings.

Step	Description
1.	Place and secure the instrument into the tribrach and onto a tripod.
2.	Using the tribrach footscrews, level the instrument with the electronic level. Press USER, STAT (F3) to access the Status Menu . Select Level & Laser Plummet to access STATUS Level & Laser Plummet .
3.	PAGE (F6) to access the Laser Plummet page. Switch on the laser plummet. Inspection of the laser plummet should be carried out on a bright, smooth and horizontal surface, like a sheet of paper.
4.	Mark the centre of the red dot on the ground.
5.	Turn the instrument through 360° slowly, carefully observing the movement of the red laser dot.
	The maximum diameter of the circular movement described by the centre of the laser point should not exceed 3 mm at a distance of 1.5 m.
6.	If the centre of the laser dot describes a perceptible circular movement or moves more than 3 mm away from the point which was first marked, an adjustment may be required. Inform your nearest Leica Geosystems authorised service workshop. Depending on brightness and surface, the diameter of the laser dot can vary. At 1.5 m it is about 2.5 mm.

5.8

Servicing the Tripod

Servicing the Tripod Step by Step

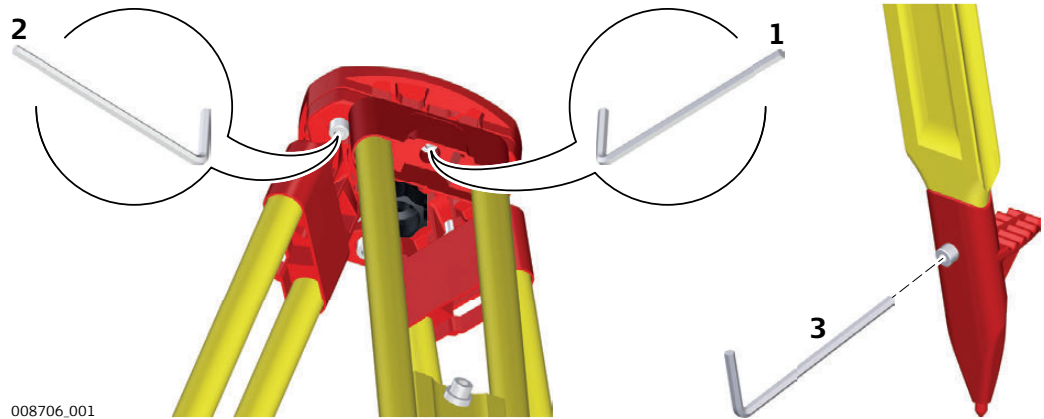

The following table explains the most common settings.

Step	Description
	The connections between metal and timber components must always be firm and tight.
1.	Tighten the leg cap screws moderately, with the supplied allen key.
2.	Tighten the articulated joints on the tripod head enough to keep the tripod legs open when lifting the tripod off the ground.
3.	Tighten the allen screws of the tripod legs.

6 Care and Transport

6.1 Transport

Transport in the field	<p>When transporting the equipment in the field, always make sure that you</p> <ul style="list-style-type: none">• either carry the product in its original transport container,• or carry the tripod with its legs splayed across your shoulder, keeping the attached product upright.
Transport in a road vehicle	<p>Never carry the product loose in a road vehicle, as it can be affected by shock and vibration. Always carry the product in its transport container, original packaging or equivalent and secure it.</p>
Shipping	<p>When transporting the product by rail, air or sea, always use the complete original Leica Geosystems packaging, transport container and cardboard box, or its equivalent, to protect against shock and vibration.</p>
Shipping, transport of batteries	<p>When transporting or shipping batteries, the person responsible for the product must ensure that the applicable national and international rules and regulations are observed. Before transportation or shipping, contact your local passenger or freight transport company.</p>
Field adjustment	<p>Periodically carry out test measurements and perform the field adjustments indicated in the User Manual, particularly after the product has been dropped, stored for long periods or transported.</p>

6.2 Storage

Product	<p>Respect the temperature limits when storing the equipment, particularly in summer if the equipment is inside a vehicle. Refer to "7 Technical Data" for information about temperature limits.</p>
Field adjustment	<p>After long periods of storage inspect the field adjustment parameters given in this user manual before using the product.</p>
Li-Ion batteries	<ul style="list-style-type: none">• Refer to "Technical Data" for information about storage temperature range.• Remove batteries from the product and the charger before storing.• After storage recharge batteries before using.• Protect batteries from damp and wetness. Wet or damp batteries must be dried before storing or use.• A storage temperature range of 0°C to +30°C / +32°F to +86°F in a dry environment is recommended to minimize self-discharging of the battery.• At the recommended storage temperature range, batteries containing a 30% to 50% charge can be stored for up to one year. After this storage period the batteries must be recharged.

6.3

Cleaning and Drying

Product and accessories

- Blow dust off lenses and prisms.
 - Never touch the glass with your fingers.
 - Use only a clean, soft, lint-free cloth for cleaning. If necessary, moisten the cloth with water or pure alcohol. Do not use other liquids; these can attack the polymer components.
-

Fogging of prisms

Prisms that are cooler than the ambient temperature tend to fog. It is not enough simply to wipe them. Keep them for some time inside your jacket or in the vehicle to allow them to adjust to the ambient temperature.

Damp products

Dry the product, the transport container, the foam inserts and the accessories at a temperature not greater than 40°C /104°F and clean them. Remove the battery cover and dry the battery compartment. Do not repack until everything is completely dry. Always close the transport container when using in the field.

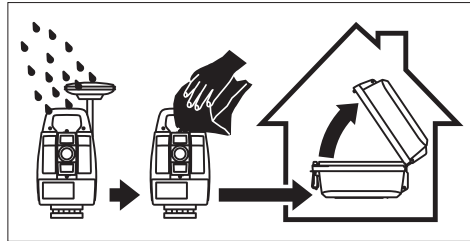

Cables and plugs

Keep plugs clean and dry. Blow away any dirt lodged in the plugs of the connecting cables.

6.4

Maintenance



An inspection of the motorisation in motorised instruments must be done in a Leica Geosystems authorised service centre. Leica Geosystems recommends an inspection of the product every 12 months.

For instruments which are in intensive or permanent use, for example tunnelling or monitoring, the recommended inspection cycle may be reduced.

7 Technical Data

7.1 Angle Measurement

Accuracy

Available angular accuracies	Standard deviation Hz, V, ISO 17123-3	Display resolution	
		["]	[mgon]
2	0.6	0.1	0.1
3	1.0	0.1	0.5
5	1.5	0.1	0.5
7	2.0	0.1	0.5

Characteristics

Absolute, continuous, diametric.

Range

Reflector	Range A		Range B		Range C	
	[m]	[ft]	[m]	[ft]	[m]	[ft]
Standard prism (GPR1)	1800	6000	3000	10000	3500	12000
Three standard prisms (GPR1)	2300	7500	4500	14700	5400	17700
360° prism (GRZ4, GRZ122)	800	2600	1500	5000	2000	7000
360° Mini prism (GRZ101)	450	1500	800	2600	1000	3300
Mini prism (GMP101)	800	2600	1200	4000	2000	7000
Reflector tape (GZM31) 60 mm x 60 mm	150	500	250	800	250	800
Machine Automation power prism (MPR122)  For Machine Control purposes only!	800	2600	1500	5000	2000	7000

Shortest measuring distance: 1.5 m

Atmospheric conditions

Range A: Strong haze, visibility 5 km; or strong sunlight, severe heat shimmer
 Range B: Light haze, visibility about 20 km; or moderate sunlight, slight heat shimmer
 Range C: Overcast, no haze, visibility about 40 km; no heat shimmer



Measurements can be made to reflector tapes over the entire range without external ancillary optics.

Accuracy

Accuracy refers to measurements to standard prisms.

EDM measuring mode	std. dev. ISO 17123-4, standard prism	std. dev. ISO 17123-4, tape	Measurement time, typical [s]*1
Standard	1 mm + 1.5 ppm	5 mm + 2 ppm	2.4
Fast	3 mm + 1.5 ppm	5 mm + 2 ppm	0.8
Tracking	3 mm + 1.5 ppm	5 mm + 2 ppm	< 0.15

*1 does not include radio transfer time to the CS.

Beam interruptions, severe heat shimmer and moving objects within the beam path can result in deviations of the specified accuracy.

The display resolution is 0.1 mm.

Characteristics

Principle: Phase measurement
 Type: Coaxial, visible red laser
 Carrier wave: 658 nm
 Measuring system: System analyser basis 100 MHz - 150 MHz

7.3

Distance Measurement without Reflectors

Range

Type	Kodak Gray Card	Range D		Range E		Range F	
		[m]	[ft]	[m]	[ft]	[m]	[ft]
R400	White side, 90 % reflective	200	660	300	990	>400	>1310
R400	Grey side, 18 % reflective	150	490	200	660	>200	>660
R1000	White side, 90 % reflective	800	2630	1000	3280	>1000	>3280
R1000	Grey side, 18 % reflective	400	1320	500	1640	>500	>1640

Range of Measurement: 1.5 m - 1200 m

Display unambiguous: up to 1200 m

Atmospheric conditions

D: Object in strong sunlight, severe heat shimmer

E: Object in shade, sky overcast

F: Underground, night and twilight

Accuracy

Standard measuring	std. dev. ISO 17123-4	Measure time, typical [s]	Measure time, maximum [s]* ¹
0 m - 500 m	2 mm + 2 ppm	3 - 6	12
>500 m	4 mm + 2 ppm	3 - 6	12

*1 does not include radio transfer time to the CS.

Object in shade, sky overcast. Beam interruptions, severe heat shimmer and moving objects within the beam path can result in deviations of the specified accuracy. The display resolution is 0.1 mm.

Characteristics

Type: Coaxial, visible red laser

Carrier wave: 658 nm

Measuring system: System analyser basis 100 MHz - 150 MHz

Laser dot size

Distance [m]	Laser dot size, approximately [mm]
at 30	7 x 10
at 50	8 x 20
at 100	16 x 25

7.4

Distance Measurement - Long Range (LO mode)

Range

The range of the long range measurements is the same for R400 and R1000.

Reflector	Range A		Range B		Range C	
	[m]	[ft]	[m]	[ft]	[m]	[ft]
Standard prism (GPR1)	2200	7300	7500	24600	>10000	>32800

Range of measurement:

1000 m to 12000 m

Display unambiguous:

up to 12000 m

Atmospheric conditions

Range A: Strong haze, visibility 5 km; or strong sunlight, severe heat shimmer

Range B: Light haze, visibility about 20 km; or moderate sunlight, slight heat shimmer

Range C: Overcast, no haze, visibility about 40 km; no heat shimmer

Accuracy

Standard measuring	std. dev. ISO 17123-4	Measure time, typical [s]* ¹	Measure time, maximum [s]
Long Range	5 mm + 2 ppm	2.5	12

*1 does not include radio transfer time to the CS.

Beam interruptions, severe heat shimmer and moving objects within the beam path can result in deviations of the specified accuracy. The display resolution is 0.1 mm.

Characteristics

Principle:

Phase measurement

Type:

Coaxial, visible red laser

Carrier wave:

658 nm



Measuring system:

System analyser basis 100 MHz - 150 MHz

7.5

Automatic Target Aiming ATR

Range ATR/LOCK

Reflector	Range ATR mode		Range Lock mode	
	[m]	[ft]	[m]	[ft]
Standard prism (GPR1)	1000	3300	800	2600
360° prism (GRZ4, GRZ122)	800	2600	600	2000
360° Mini prism (GRZ101)	350	1150	200	660
Mini prism (GMP101)	500	1600	400	1300
Reflector tape 60 mm x 60 mm	45	150	not qualified	
Machine Automation power prism (MPR122)	600	2000	500	1600
 For Machine Control purposes only!				
 The maximum range can be restricted by poorer conditions, for example rain.				

Shortest measuring distance: 360° prism ATR: 1.5 m
 Shortest measuring distance: 360° prism LOCK: 5 m

ATR accuracy with the GPR1 prism

ATR angle accuracy Hz, V (std. dev. ISO 17123-3): 1 " (0.3 mgon)
 Base Positioning accuracy (std.dev.): ± 1 mm

System accuracy with ATR

- The accuracy with which the position of a prism can be determined with Automatic Target Aiming (ATR) depends on several factors such as internal ATR accuracy, instrument angle accuracy, prism type, selected EDM measuring program and the external measuring conditions. The ATR has a basic standard deviation level of ± 1 mm.
- The following graph shows the ATR standard deviation based on three different prism types, distances and instrument accuracies.

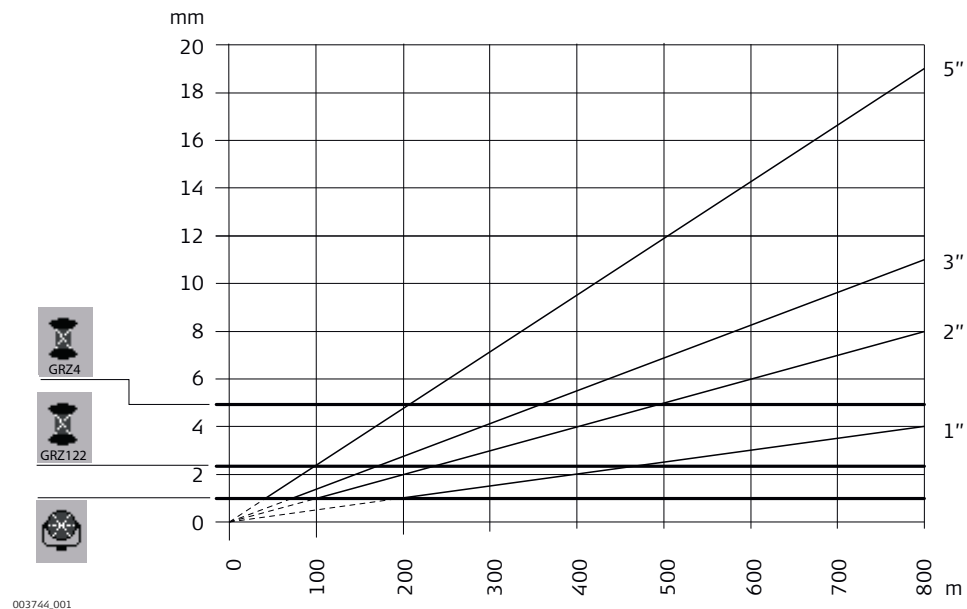

Leica GRZ4 prism (360°)

Leica GRZ122 prism (360°)



Leica circular prisms and Leica circular Mini prisms
 mm ATR accuracy [mm]
 m Distance measurement [m]
 " Instrument angle accuracy ["]

Maximum speed in lock mode
 Maximum tangential speed: 5 m/s at 20 m; 25 m/s at 100 m
 Maximum radial speed with **<EDM Mode: Tracking>** 5 m/s

Searching
 Typical search time in field of view: 1.5 s
 Field of view: 1°25'/1.55 gon
 Definable search windows: Yes

Characteristics
 Principle: Digital image processing
 Type: Infrared laser

7.6 PowerSearch PS

Range

Reflector	Range PS	
	[m]	[ft]
Standard prism (GPR1)	300	1000
360° prism (GRZ4, GRZ122)	300*	1000*
Mini prism (GMP101)	100	330
Machine Automation power prism (MPR122)  For Machine Control purposes only!	300*	1000*

Measurements at the vertical limits of the fan or under unfavourable atmospheric conditions may reduce the maximum range. (*optimally aligned to the instrument)

Shortest measuring distance: 1.5 m

Searching
 Typical search time: < 10 s
 Default search area: Hz: 400 gon, V: 40 gon
 Definable search windows: Yes

Characteristics
 Principle: Digital signal processing
 Type: Infrared laser

7.7

Conformity to National Regulations

7.7.1

Communication side cover with Bluetooth

Conformity to national regulations

- FCC Part 15 (applicable in US).
- Hereby, Leica Geosystems AG, declares that the instrument with Communication side cover is in compliance with the essential requirements and other relevant provisions of Directive 1999/5/EC and other applicable European Directives. The declaration of conformity may be consulted at <http://www.leica-geosystems.com/ce>.



Class 1 equipment according European Directive 1999/5/EC (R&TTE) can be placed on the market and be put into service without restrictions in any EEA Member state.

- The conformity for countries with other national regulations not covered by the FCC part 15 or European directive 1999/5/EC has to be approved prior to use and operation.
- Japanese Radio Law and Japanese Telecommunications Business Law Compliance.
 - This device is granted pursuant to the Japanese Radio Law and the Japanese Telecommunications Business Law.
 - This device should not be modified (otherwise the granted designation number will become invalid).

Frequency band

2402 - 2480 MHz

Output power

Bluetooth:
4 mW max.

Antenna

Type:	Internal Microstrip antenna
Gain:	1.5 dBi

7.7.2

RadioHandle

Conformity to national regulations

- FCC Part 15 (applicable in US)
- Hereby, Leica Geosystems AG, declares that the RadioHandle is in compliance with the essential requirements and other relevant provisions of Directive 1999/5/EC and other applicable European Directives. The declaration of conformity may be consulted at <http://www.leica-geosystems.com/ce>.



Class 1 equipment according European Directive 1999/5/EC (R&TTE) can be placed on the market and be put into service without restrictions in any EEA Member state.

- The conformity for countries with other national regulations not covered by the FCC part 15 or European directive 1999/5/EC has to be approved prior to use and operation.
- Japanese Radio Law and Japanese Telecommunications Business Law Compliance.
 - This device is granted pursuant to the Japanese Radio Law and the Japanese Telecommunications Business Law.
 - This device should not be modified (otherwise the granted designation number will become invalid).

Frequency Band

RH16	Limited to 2402 - 2480 MHz
RH17	Limited to 2402 - 2480 MHz

Output power

< 100 mW (e. i. r. p.)

Antenna

Type:	$\lambda/2$ dipole antenna
Gain:	2 dBi
Connector:	Special customized SMB

7.7.3

Dangerous Goods Regulations

Dangerous Goods Regulations

The products of Leica Geosystems are powered by Lithium batteries.

Lithium batteries can be dangerous under certain conditions and can pose a safety hazard. In certain conditions, Lithium batteries can overheat and ignite.



When carrying or shipping your Leica product with Lithium batteries onboard a commercial aircraft, you must do so in accordance with the **IATA Dangerous Goods Regulations**.



Leica Geosystems has developed **Guidelines** on "How to carry Leica products" and "How to ship Leica products" with Lithium batteries. Before any transportation of a Leica product, we ask you to consult these guidelines on our web page (<http://www.leica-geosystems.com/dgr>) to ensure that you are in accordance with the IATA Dangerous Goods Regulations and that the Leica products can be transported correctly.



Damaged or defective batteries are prohibited from being carried or transported onboard any aircraft. Therefore, ensure that the condition of any battery is safe for transportation.

7.8

General Technical Data of the Instrument

Telescope	Magnification:	30 x
	Clear objective diameter:	40 mm
	Focusing:	1.7 m/5.6 ft to infinity
	Field of view:	1°30'/1.66 gon. 2.7 m at 100 m

Compensator

Angular accuracy TS12P ["]	Setting accuracy		Setting range	
	["]	[mgon]	[']	[gon]
2	0.5	0.2	4	0.07
3	1.0	0.3	4	0.07
5	1.5	0.5	4	0.07
7	1.5	0.5	4	0.07

Level

Circular level sensitivity:	6'/2 mm
Electronic level resolution:	2"

Control unit

Display:	1/4 VGA (320 x 240 pixels), colour, graphics capable LCD, illumination, touch screen
Keyboard:	28 keys including 6 function keys and 12 alphanumeric keys, illumination
Angle Display:	360°", 360° decimal, 400 gon, 6400 mil, V %
Distance Display:	m, ft int, ft us, ft int inch, ft us inch
Touch screen if fitted:	Toughened film on glass

Instrument Ports

Port	Name	Description
Port 1	Port 1	<ul style="list-style-type: none"> 5 pin LEMO-0 for power, communication, data transfer. This port is located at the base of the instrument.
Port 2	Handle	<ul style="list-style-type: none"> Hotshoe connection for RadioHandle with RCS. This port is located on top of Communication side cover.
Port 3	BT	<ul style="list-style-type: none"> Bluetooth module for communication. This port is housed within Communication side cover.

Instrument Dimensions

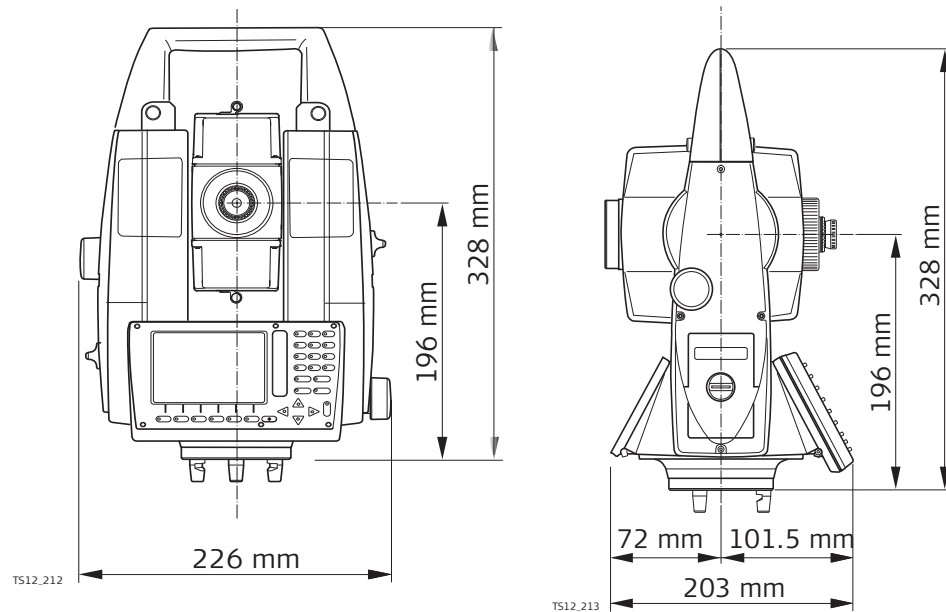

Weight

Instrument:	4.8 - 5.5 kg
Tribrach:	0.8 kg
Internal battery:	0.2 kg

Recording

Data can be recorded onto a CompactFlash card.

Type	Capacity [MB]	Capacity [GB]	Measurements per MB
CompactFlash card	256	1024	1750

Laser plummet

Type:	Visible red laser class 2
Location:	In standing axis of instrument
Accuracy:	Deviation from plumb line: 1.5 mm (2 sigma) at 1.5 m instrument height
Diameter of laser point:	2.5 mm at 1.5 m instrument height

Drives

Type:	Endless horizontal and vertical drives
-------	--

Motorisation

Maximum rotating speed:	50 gon/s
-------------------------	----------

Power

External supply voltage:	Nominal voltage 12.8 V DC, Range 11.5 V-13.5 V
--------------------------	--

Internal Battery

Type:	Li-Ion
Voltage:	7.4 V
Capacity:	GEB222: 6.0 Ah

External battery

Type:	NiMH
Voltage:	12 V
Capacity:	GEB371: 9.0 Ah

Environmental specifications

Temperature

Type	Operating temperature [°C]	Storage temperature [°C]
TS12P	-20 to +50	-40 to +70
Leica CompactFlash cards, all sizes	-40 to +80	-40 to +80
Battery internal	-20 to +55	-40 to +70
Bluetooth	-30 to +60	-40 to +80

Protection against water, dust and sand

Type	Protection
TS12P	IP54 (IEC 60529)

Humidity

Type	Protection
TS12P	Max 95 % non condensing The effects of condensation are to be effectively counteracted by periodically drying out the instrument.

Reflectors

Type	Additive Constant [mm]	ATR	PS
Standard prism, GPR1	0.0	yes	yes
Mini prism, GMP101	+17.5	yes	yes
360° prism, GRZ4 / GRZ122	+23.1	yes	yes
360° Mini prism, GRZ101	+30.0	yes	not recommended
Reflector tape S, M, L	+34.4	yes	no
Reflectorless	+34.4	no	no
Machine Automation power prism, MPR122  For Machine Control purposes only!	+28.1	yes	yes

There are no special prisms required for ATR or for PS.

Electronic Guide Light EGL

Working range:	5 m to 150 m (15 ft to 500 ft)
Position accuracy:	5 cm at 100 m (1.97" at 330 ft)

Automatic corrections

The following automatic corrections are made:

- Line of sight error
- Tilting axis error
- Earth curvature
- Circle eccentricity
- Compensator index error
- Vertical index error
- Standing axis tilt
- Refraction
- ATR zero point error

Use of scale correction

By entering a scale correction, reductions proportional to distance can be taken into account.

- Atmospheric correction.
- Reduction to mean sea level.
- Projection distortion.

Atmospheric correction $\Delta D1$

The slope distance displayed is correct if the scale correction in ppm, mm/km, which has been entered corresponds to the atmospheric conditions prevailing at the time of the measurement.

The atmospheric correction includes:

- Adjustments for air pressure
- Air temperature
- Relative humidity

For highest precision distance measurements, the atmospheric correction should be determined with an accuracy of 1 ppm. The following parameters must be redetermined:

- Air temperature to 1 °C
- Air pressure to 3 mbar
- Relative humidity to 20 %

Air humidity

The air humidity influences the distance measurement if the climate is extremely hot and damp.

For high precision measurements, the relative humidity must be measured and entered along with the air pressure and the temperature.

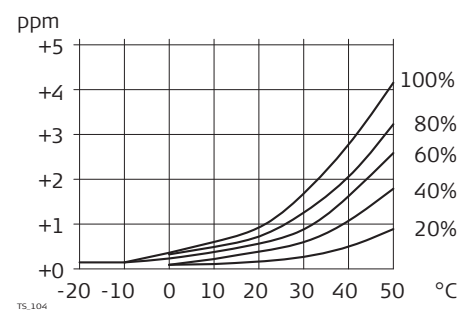
Air humidity correction

ppm Air humidity correction [mm/km]
 % Relative humidity [%]
 °C Air temperature [°C]

Index n

Type	Index n	carrier wave [nm]
combined EDM	1.0002863	658

The index n is calculated from the formula of the IAG Resolutions (1999), and is valid for:

Air pressure p: 1013.25 mbar
 Air temperature t: 12 °C
 Relative air humidity h: 60 %

Formulas

Formula for visible red laser

$$\Delta D_1 = 286.338 - \left[\frac{0.29535 \cdot p}{(1 + \alpha \cdot t)} - \frac{4.126 \cdot 10^{-4} \cdot h}{(1 + \alpha \cdot t)} \cdot 10^x \right]$$

002419_002

ΔD_1 Atmospheric correction [ppm]

p Air pressure [mbar]

t Air temperature [°C]

h Relative humidity [%]

$\alpha = \frac{1}{273.15}$

x $(7.5 \cdot t / (237.3 + t)) + 0.7857$

If the basic value of 60 % relative humidity as used by the EDM is retained, the maximum possible error in the calculated atmospheric correction is 2 ppm, 2 mm/km.

Reduction to mean sea level ΔD_2

The values for ΔD_2 are always negative and are derived from the following formula:

$$\Delta D_2 = - \frac{H}{R} \cdot 10^6$$

TS.106

ΔD_2 Reduction to mean sea level [ppm]

H Height of EDM above sea level [m]

R $6.378 \cdot 10^6$ m

Projection distortion ΔD_3

The magnitude of the projection distortion is in accordance with the projection system used in a particular country, for which official tables are generally available. The following formula is valid for cylindrical projections such as that of Gauss-Krüger:

$$\Delta D_3 = \frac{X^2}{2R^2} \cdot 10^6$$

TS.107

ΔD_3 Projection distortion [ppm]

X Easting, distance from projection zero line with the scale factor 1 [km]

R $6.378 \cdot 10^6$ m

In countries where the scale factor is not unity, this formula cannot be directly applied.

Atmospheric corrections °C

Atmospheric corrections in ppm with temperature [°C], air pressure [mb] and height [m] at 60 % relative humidity.

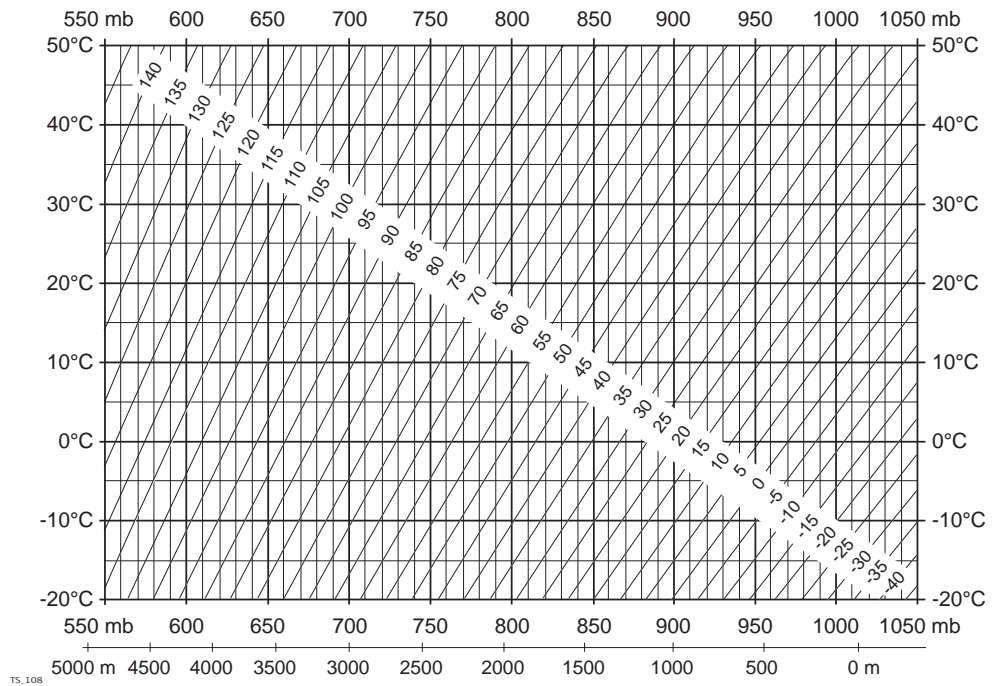

Atmospheric correction °F

Atmospheric corrections in ppm with temperature [°F], air pressure [inch Hg] and height [ft] at 60 % relative humidity.

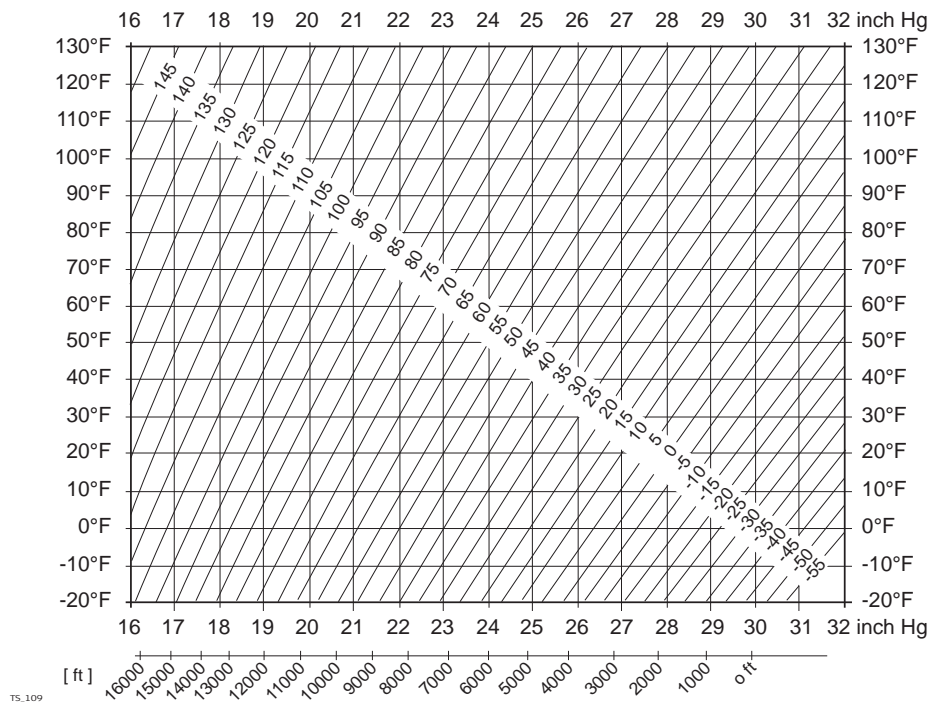

Measurements

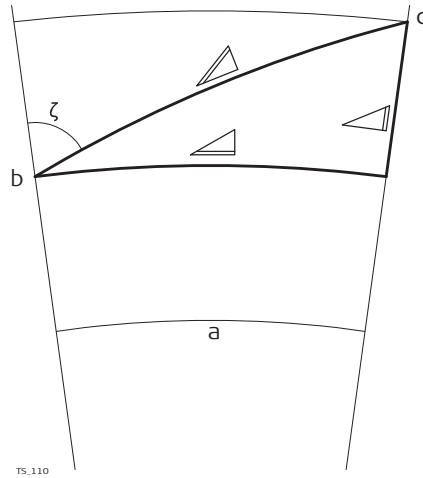

- a) Mean Sea Level
- b) Instrument
- c) Reflector
- ▴ Slope distance
- ▴ Horizontal distance
- ▴ Height difference

Reflector types

The reduction formulas are valid for measurements to all reflector types:

- measurements to prisms, to reflector tape and reflectorless measurements.

Formulas

The instrument calculates the slope distance, horizontal distance, height difference in accordance with the following formulas:

$$\triangle = D_0 \cdot (1 + \text{ppm} \cdot 10^{-6}) + \text{mm}$$

TS.111

- ▴ Displayed slope distance [m]
- D_0 Uncorrected distance [m]
- ppm Atmospheric scale correction [mm/km]
- mm Additive constant of the reflector [mm]

$$\triangle = Y - A \cdot X \cdot Y$$

TS.112

- ▴ Horizontal distance [m]
- ▴ Height difference [m]

$$Y \triangle * |\sin \zeta|$$

$$X \triangle * \cos \zeta$$

ζ Vertical circle reading

$$A (1 - k/2)/R = 1.47 \cdot 10^{-7} [\text{m}^{-1}]$$

$$B (1 - k)/2R = 6.83 \cdot 10^{-8} [\text{m}^{-1}]$$

k 0.13 (mean refraction coefficient)

$$R 6.378 \cdot 10^6 \text{ m (radius of the earth)}$$

Earth curvature ($1/R$) and mean refraction coefficient (k) are automatically taken into account when calculating the horizontal distance and height difference. The calculated horizontal distance relates to the station height and not to the reflector height.

Distance measuring program Averaging

In the distance measuring program Averaging, the following values are displayed:

- D Slope distance as arithmetic mean of all measurements
- s Standard deviation of a single measurement
- n Number of measurements

These values are calculated as follows:

$$\bar{D} = \frac{1}{n} \cdot \sum_{i=1}^n D_i$$

TS.114

\bar{D} Slope distance as arithmetic mean of all measurements

Σ Sum

D_i Single slope distance measurement

n Number of measurements

$$s = \sqrt{\frac{\sum_{i=1}^n (D_i - \bar{D})^2}{n - 1}} = \sqrt{\frac{\sum_{i=1}^n D_i^2 - \frac{1}{n} \left(\sum_{i=1}^n D_i \right)^2}{n - 1}}$$

TS.115

s Standard deviation of a single slope distance measurement

Σ Sum

\bar{D} Slope distance as arithmetic mean of all measurements

D_i Single slope distance measurement

n Number of distance measurements

The standard deviation $s_{\bar{D}}$ of the arithmetic mean of the distance can be calculated as follows:

$$s_{\bar{D}} = \frac{s}{\sqrt{n}}$$

TS.116

$s_{\bar{D}}$ Standard deviation of the arithmetic mean of the distance

s Standard deviation of a single measurement

n Number of measurements

Software Licence Agreement

This product contains software that is preinstalled on the product, or that is supplied to you on a data carrier medium, or that can be downloaded by you online according to prior authorisation from Leica Geosystems. Such software is protected by copyright and other laws and its use is defined and regulated by the Leica Geosystems Software Licence Agreement, which covers aspects such as, but not limited to, Scope of the Licence, Warranty, Intellectual Property Rights, Limitation of Liability, Exclusion of other Assurances, Governing Law and Place of Jurisdiction. Please make sure, that at any time you fully comply with the terms and conditions of the Leica Geosystems Software Licence Agreement.

Such agreement is provided together with all products and can also be referred to and downloaded at the Leica Geosystems home page at <http://www.leica-geosystems.com/swlicense> or collected from your Leica Geosystems distributor.

You must not install or use the software unless you have read and accepted the terms and conditions of the Leica Geosystems Software Licence Agreement. Installation or use of the software or any part thereof, is deemed to be an acceptance of all the terms and conditions of such Licence Agreement. If you do not agree to all or some of the terms of such Licence Agreement, you must not download, install or use the software and you must return the unused software together with its accompanying documentation and the purchase receipt to the distributor from whom you purchased the product within ten (10) days of purchase to obtain a full refund of the purchase price.

Open Source Information

The software on the product may contain copyright-protected software that is licensed under various open source licences.

Copies of the corresponding licences

- are provided together with the product (for example in the About panel of the software)
- can be downloaded on <http://opensource.leica-geosystems.com>

If foreseen in the corresponding open source licence, you may obtain the corresponding source code and other related data on <http://opensource.leica-geosystems.com>.

Contact opensource@leica-geosystems.com in case you need additional information.

827621-1.0.0en

Original text

Printed in Switzerland

© 2015 Leica Geosystems AG, Heerbrugg, Switzerland

Leica Geosystems AG

Heinrich-Wild-Strasse

CH-9435 Heerbrugg

Switzerland

Phone +41 71 727 31 31

www.leica-geosystems.com

- when it has to be **right**

Leica
Geosystems