

Leica GS25 User Manual

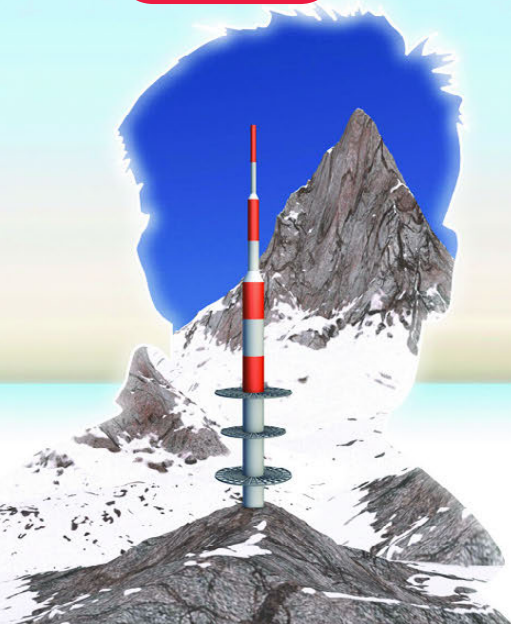

Version 3.0
English

- when it has to be **right**

Leica
Geosystems

Introduction

Purchase

Congratulations on the purchase of a Leica GS25 GNSS instrument.



This manual contains important safety directions as well as instructions for setting up the product and operating it. Refer to "1 Safety Directions" for further information. Read carefully through the User Manual before you switch on the product.

Product Identification

The model and serial number of your product are indicated on the type plate. Always refer to this information when you need to contact your agency or Leica Geosystems authorised service workshop.



Trademarks



- Windows is a registered trademark of Microsoft Corporation in the United States and other countries
 - *Bluetooth*[®] is a registered trademark of Bluetooth SIG, Inc.
 - SD Logo is a trademark of SD-3C, LLC.
- All other trademarks are the property of their respective owners.

Validity of this manual

This manual applies to the GS25 GNSS instrument.

Available documentation

Name	Description/Format		
GS25 Quick Guide	Provides an overview of the product together with technical data and safety directions. Intended as a quick reference guide.	✓	✓
GS25 User Manual	All instructions required in order to operate the product to a basic level are contained in the User Manual. Provides an overview of the product together with technical data and safety directions.	-	✓

Name	Description/Format		
Viva Series Technical Reference Manual	Overall comprehensive guide to the product and application functions. Included are detailed descriptions of special software/hardware settings and software/hardware functions intended for technical specialists.	-	✓

Refer to the following resources for all GS25 documentation/software:

- the Leica USB documentation card
- <https://myworld.leica-geosystems.com>

myWorld@Leica Geosystems (<https://myworld.leica-geosystems.com>) offers a wide range of services, information and training material.

With direct access to myWorld, you are able to access all relevant services whenever it is convenient for you, 24 hours a day, 7 days per week. This increases your efficiency and keeps you and your equipment instantly updated with the latest information from Leica Geosystems.

Service	Description
myProducts	Add all products that you and your company own and explore your world of Leica Geosystems: View detailed information on your products and update your products with the latest software and keep up-to-date with the latest documentation.
myService	View the current service status and full service history of your products in Leica Geosystems service centres. Access detailed information on the services performed and download your latest calibration certificates and service reports.
mySupport	View the current service status and full service history of your products in Leica Geosystems service centres. Access detailed information on the services performed and download your latest calibration certificates and service reports.
myTraining	Enhance your product knowledge with Leica Geosystems Campus - Information, Knowledge, Training. Study the latest online training material on your products and register for seminars or courses in your country.
myTrusted Services	Add your subscriptions and manage users for Leica Geosystems Trusted Services, the secure software services, that assist you to optimise your workflow and increase your efficiency.

Table of Contents

In this manual	Chapter	Page
1	Safety Directions	6
1.1	General Introduction	6
1.2	Definition of Use	7
1.3	Limits of Use	7
1.4	Responsibilities	7
1.5	Hazards of Use	8
1.6	Electromagnetic Compatibility EMC	12
1.7	FCC Statement, Applicable in U.S.	13
2	Description of the System	14
2.1	Overview	14
2.2	System Components	14
2.3	System Concept	15
2.3.1	Software Concept	15
2.3.2	Power Concept	15
2.3.3	Data Storage Concept	16
2.4	Container Contents	17
2.5	Instrument Components	19
3	User Interface	20
3.1	Keyboard	20
3.2	Operating Principles	21
3.3	Working with the User Interface	22
3.3.1	Status Functions	22
3.3.2	Configuration	24
3.3.3	Tools	25
4	Operation	27
4.1	Equipment Setup	27
4.1.1	Setting up as a Post-Processing Base	27
4.1.2	Setting up as a Real-Time Base	30
4.1.3	Setting up as a Real-Time Rover	34
4.1.4	Using the Backpack	37
4.1.5	Fixing the Field Controller to a Holder and Pole	38
4.1.6	Connecting to a Personal Computer	40
4.1.7	Connecting to the Web Server	43
4.2	Batteries	45
4.2.1	Operating Principles	45
4.2.2	Battery for GS25	46
4.3	Working with the Memory Device	47
4.4	Working with the RTK Device	48
4.5	LED Indicators on GS25	51
4.6	Guidelines for Correct Results with GNSS Surveys	52
5	Care and Transport	53
5.1	Transport	53
5.2	Storage	53
5.3	Cleaning and Drying	54

6	Technical Data	55
6.1	GS25 Technical Data	55
	6.1.1 Tracking Characteristics	55
	6.1.2 Accuracy	55
	6.1.3 Technical Data	56
6.2	Antennas Technical Data	59
6.3	Conformity to National Regulations	62
	6.3.1 GS25	62
	6.3.2 SLR5-1, SATELLINE M3-TR1	63
	6.3.3 SLR6-1, SATELLINE M3-TR4	64
	6.3.4 SLG1-2, Telit UC864-G	65
	6.3.5 Dangerous Goods Regulations	66
7	Software Licence Agreement	67
Appendix A	Pin Assignments and Sockets	68

1 Safety Directions

1.1 General Introduction

Description

The following directions enable the person responsible for the product, and the person who actually uses the equipment, to anticipate and avoid operational hazards.

The person responsible for the product must ensure that all users understand these directions and adhere to them.

About Warning Messages





Warning messages are an essential part of the safety concept of the instrument. They appear wherever hazards or hazardous situations can occur.

Warning messages...

- make the user alert about direct and indirect hazards concerning the use of the product.
- contain general rules of behaviour.

For the users' safety, all safety instructions and safety messages shall be strictly observed and followed! Therefore, the manual must always be available to all persons performing any tasks described here.

DANGER, WARNING, CAUTION and **NOTICE** are standardised signal words for identifying levels of hazards and risks related to personal injury and property damage. For your safety, it is important to read and fully understand the following table with the different signal words and their definitions! Supplementary safety information symbols may be placed within a warning message as well as supplementary text.

Type	Description
 DANGER	Indicates an imminently hazardous situation which, if not avoided, will result in death or serious injury.
 WARNING	Indicates a potentially hazardous situation or an unintended use which, if not avoided, could result in death or serious injury.
 CAUTION	Indicates a potentially hazardous situation or an unintended use which, if not avoided, may result in minor or moderate injury.
NOTICE	Indicates a potentially hazardous situation or an unintended use which, if not avoided, may result in appreciable material, financial and environmental damage.
	Important paragraphs which must be adhered to in practice as they enable the product to be used in a technically correct and efficient manner.

1.2 Definition of Use

Intended use	<ul style="list-style-type: none">• Computing with software.• Carrying out measurement tasks using various GNSS measuring techniques.• Recording GNSS and point related data.• Data communication with external appliances.• Measuring raw data and computing coordinates using carrier phase and code signal from GNSS satellites.
Reasonably foreseeable misuse	<ul style="list-style-type: none">• Use of the product without instruction.• Use outside of the intended use and limits.• Disabling safety systems.• Removal of hazard notices.• Opening the product using tools, for example screwdriver, unless this is permitted for certain functions.• Modification or conversion of the product.• Use after misappropriation.• Use of products with obvious damages or defects.• Use with accessories from other manufacturers without the prior explicit approval of Leica Geosystems.• Inadequate safeguards at the working site.• Controlling of machines, moving objects or similar monitoring application without additional control and safety installations.

1.3 Limits of Use

Environment	Suitable for use in an atmosphere appropriate for permanent human habitation: not suitable for use in aggressive or explosive environments.
 DANGER	Local safety authorities and safety experts must be contacted before working in hazardous areas, or close to electrical installations or similar situations by the person in charge of the product.

1.4 Responsibilities

Manufacturer of the product	Leica Geosystems AG, CH-9435 Heerbrugg, hereinafter referred to as Leica Geosystems, is responsible for supplying the product, including the user manual and original accessories, in a safe condition.
Person responsible for the product	<p>The person responsible for the product has the following duties:</p> <ul style="list-style-type: none">• To understand the safety instructions on the product and the instructions in the user manual.• To ensure that it is used in accordance with the instructions.• To be familiar with local regulations relating to safety and accident prevention.• To inform Leica Geosystems immediately if the product and the application becomes unsafe.• To ensure that the national laws, regulations and conditions for the operation of e.g. radio transmitters or lasers are respected.• To ensure that the radio modem is not operated without the permission of the local authorities on frequencies and/or output power levels other than those specifically reserved and intended for use without a specific permit. <p>The internal and external radio modems have been designed to operate on frequency ranges and output power ranges, the exact use of which differs from one region and/or country to another.</p>

1.5

Hazards of Use



CAUTION

Watch out for erroneous measurement results if the product has been dropped or has been misused, modified, stored for long periods or transported.

Precautions:

Periodically carry out test measurements and perform the field adjustments indicated in the user manual, particularly after the product has been subjected to abnormal use as well as before and after important measurements.



DANGER

Because of the risk of electrocution, it is dangerous to use poles, levelling staffs and extensions in the vicinity of electrical installations such as power cables or electrical railways.

Precautions:

Keep at a safe distance from electrical installations. If it is essential to work in this environment, first contact the safety authorities responsible for the electrical installations and follow their instructions.



WARNING

During dynamic applications, for example stakeout procedures there is a danger of accidents occurring if the user does not pay attention to the environmental conditions around, for example obstacles, excavations or traffic.

Precautions:

The person responsible for the product must make all users fully aware of the existing dangers.



WARNING

Inadequate securing of the working site can lead to dangerous situations, for example in traffic, on building sites and at industrial installations.

Precautions:

Always ensure that the working site is adequately secured. Adhere to the regulations governing safety, accident prevention and road traffic.



CAUTION

If the accessories used with the product are not properly secured and the product is subjected to mechanical shock, for example blows or falling, the product may be damaged or people can sustain injury.

Precautions:

When setting-up the product, make sure that the accessories are correctly adapted, fitted, secured, and locked in position.

Avoid subjecting the product to mechanical stress.



WARNING

If the product is used with accessories, for example masts, staffs, poles, you may increase the risk of being struck by lightning.

Precautions:

Do not use the product in a thunderstorm.

⚠ DANGER

If the product is used with accessories, for example on masts, staffs, poles, you may increase the risk of being struck by lightning. Danger from high voltages also exists near power lines. Lightning, voltage peaks, or the touching of power lines can cause damage, injury and death.

Precautions:

- Do not use the product in a thunderstorm as you can increase the risk of being struck by lightning.
- Be sure to remain at a safe distance from electrical installations. Do not use the product directly under or close to power lines. If it is essential to work in such an environment contact the safety authorities responsible for electrical installations and follow their instructions.
- If the product has to be permanently mounted in an exposed location, it is advisable to provide a lightning conductor system. A suggestion on how to design a lightning conductor for the product is given below. Always follow the regulations in force in your country regarding grounding antennas and masts. These installations must be carried out by an authorised specialist.
- To prevent damages due to indirect lightning strikes (voltage spikes) cables, for example for antenna, power source or modem should be protected with appropriate protection elements, like a lightning arrester. These installations must be carried out by an authorised specialist.
- If there is a risk of a thunderstorm, or if the equipment is to remain unused and unattended for a long period, protect your product additionally by unplugging all systems components and disconnecting all connecting cables and supply cables, for example, instrument - antenna.

Lightning conductors

Suggestion for design of a lightning conductor for a GNSS system:

1) On non-metallic structures

Protection by air terminals is recommended. An air terminal is a pointed solid or tubular rod of conducting material with proper mounting and connection to a conductor. The position of four air terminals can be uniformly distributed around the antenna at a distance equal to the height of the air terminal.

The air terminal diameter should be 12 mm for copper or 15 mm for aluminium. The height of the air terminals should be 25 cm to 50 cm. All air terminals should be connected to the down conductors. The diameter of the air terminal should be kept to a minimum to reduce GNSS signal shading.

2) On metallic structures

Protection is as described for non-metallic structures, but the air terminals can be connected directly to the conducting structure without the need for down conductors.

Air terminal arrangement, plan view

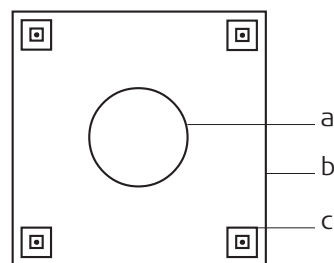

- a) Antenna
- b) Support structure
- c) Air terminal

Grounding the instrument/antenna

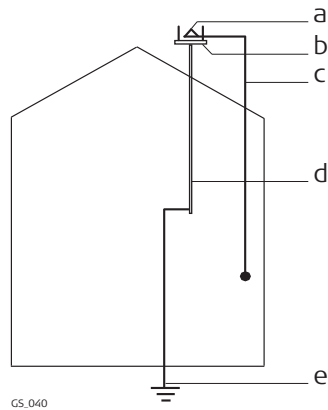

- a) Antenna
- b) Lightning conductor array
- c) Antenna/instrument connection
- d) Metallic mast
- e) Connection to earth



CAUTION

During the transport, shipping or disposal of batteries it is possible for inappropriate mechanical influences to constitute a fire hazard.

Precautions:

Before shipping the product or disposing of it, discharge the batteries by running the product until they are flat.

When transporting or shipping batteries, the person in charge of the product must ensure that the applicable national and international rules and regulations are observed. Before transportation or shipping contact your local passenger or freight transport company.



WARNING

High mechanical stress, high ambient temperatures or immersion into fluids can cause leakage, fire or explosions of the batteries.

Precautions:

Protect the batteries from mechanical influences and high ambient temperatures. Do not drop or immerse batteries into fluids.



WARNING

If battery terminals are short circuited e.g. by coming in contact with jewellery, keys, metalized paper or other metals, the battery can overheat and cause injury or fire, for example by storing or transporting in pockets.

Precautions:

Make sure that the battery terminals do not come into contact with metallic objects.



WARNING

Incorrect fastening of the external antenna to vehicles or transporters poses the risk of the equipment being broken by mechanical influence, vibration or airstream. This may result in accident and physical injury.

Precautions:

Attach the external antenna professionally. The external antenna must be secured additionally, for example by use of a safety cord. Ensure that the mounting device is correctly mounted and able to carry the weight of the external antenna (>1 kg) safely.



WARNING

If the product is improperly disposed of, the following can happen:

- If polymer parts are burnt, poisonous gases are produced which may impair health.
- If batteries are damaged or are heated strongly, they can explode and cause poisoning, burning, corrosion or environmental contamination.
- By disposing of the product irresponsibly you may enable unauthorised persons to use it in contravention of the regulations, exposing themselves and third parties to the risk of severe injury and rendering the environment liable to contamination.

Precautions:

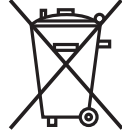

The product must not be disposed with household waste.

Dispose of the product appropriately in accordance with the national regulations in force in your country.





Always prevent access to the product by unauthorised personnel.

Product-specific treatment and waste management information can be downloaded from the Leica Geosystems home page at <http://www.leica-geosystems.com/treatment> or received from your Leica Geosystems distributor.



WARNING

Only Leica Geosystems authorised service workshops are entitled to repair these products.

Description	The term Electromagnetic Compatibility is taken to mean the capability of the product to function smoothly in an environment where electromagnetic radiation and electrostatic discharges are present, and without causing electromagnetic disturbances to other equipment.
 WARNING	Electromagnetic radiation can cause disturbances in other equipment. Although the product meets the strict regulations and standards which are in force in this respect, Leica Geosystems cannot completely exclude the possibility that other equipment may be disturbed.
 CAUTION	<p>There is a risk that disturbances may be caused in other equipment if the product is used with accessories from other manufacturers, for example field computers, personal computers or other electronic equipment, non-standard cables or external batteries.</p> <p>Precautions: Use only the equipment and accessories recommended by Leica Geosystems. When combined with the product, they meet the strict requirements stipulated by the guidelines and standards. When using computers or other electronic equipment, pay attention to the information about electromagnetic compatibility provided by the manufacturer.</p>
 CAUTION	<p>Disturbances caused by electromagnetic radiation can result in erroneous measurements. Although the product meets the strict regulations and standards which are in force in this respect, Leica Geosystems cannot completely exclude the possibility that the product may be disturbed by intense electromagnetic radiation, for example, near radio transmitters, two-way radios or diesel generators.</p> <p>Precautions: Check the plausibility of results obtained under these conditions.</p>
 CAUTION	<p>If the product is operated with connecting cables attached at only one of their two ends, for example external supply cables, interface cables, the permitted level of electromagnetic radiation may be exceeded and the correct functioning of other products may be impaired.</p> <p>Precautions: While the product is in use, connecting cables, for example product to external battery, product to computer, must be connected at both ends.</p>
Radios or Digital Cellular Phones	Use of product with radio or digital cellular phone devices:
 WARNING	<p>Electromagnetic fields can cause disturbances in other equipment, in installations, in medical devices, for example pacemakers or hearing aids and in aircraft. It can also affect humans and animals.</p> <p>Precautions: Although the product meets the strict regulations and standards which are in force in this respect, Leica Geosystems cannot completely exclude the possibility that other equipment can be disturbed or that humans or animals can be affected.</p> <ul style="list-style-type: none"> • Do not operate the product with radio or digital cellular phone devices in the vicinity of filling stations or chemical installations, or in other areas where an explosion hazard exists. • Do not operate the product with radio or digital cellular phone devices near to medical equipment. • Do not operate the product with radio or digital cellular phone devices in aircraft.

1.7

FCC Statement, Applicable in U.S.



The greyed paragraph below is only applicable for products without radio.



WARNING

This equipment has been tested and found to comply with the limits for a Class B digital device, pursuant to part 15 of the FCC rules.

These limits are designed to provide reasonable protection against harmful interference in a residential installation.

This equipment generates, uses and can radiate radio frequency energy and, if not installed and used in accordance with the instructions, may cause harmful interference to radio communications. However, there is no guarantee that interference will not occur in a particular installation.

If this equipment does cause harmful interference to radio or television reception, which can be determined by turning the equipment off and on, the user is encouraged to try to correct the interference by one or more of the following measures:

- Reorient or relocate the receiving antenna.
- Increase the separation between the equipment and the receiver.
- Connect the equipment into an outlet on a circuit different from that to which the receiver is connected.
- Consult the dealer or an experienced radio/TV technician for help.



WARNING

Changes or modifications not expressly approved by Leica Geosystems for compliance could void the user's authority to operate the equipment.

Labelling GS25



0012215_001

Type : GS25	S.No.:
Equip.No.:	Art.No.:
Power: 12-24V ~~, nominal/2.5A max.	
Leica Geosystems AG	IC:
CH-9435 Heerbrugg	Contains transmitter module:
Manufactured: 2010	FCC-ID:
Made in Switzerland	Bluetooth QD ID:

This device complies with part 15 of the FCC Rules. Operation is subject to the following two conditions:
(1) This device may not cause harmful interference, and (2) this device must accept any interference received, including interference that may cause undesired operation.

Labelling internal battery GEB241, GEB242



002661_002

This device complies with part 15 of the FCC Rules. Operation is subject to the following two conditions: (1) This device may not cause harmful interference, and (2) this device must accept any interference received, including interference that may cause undesired operation.



2 Description of the System

2.1 Overview

System components

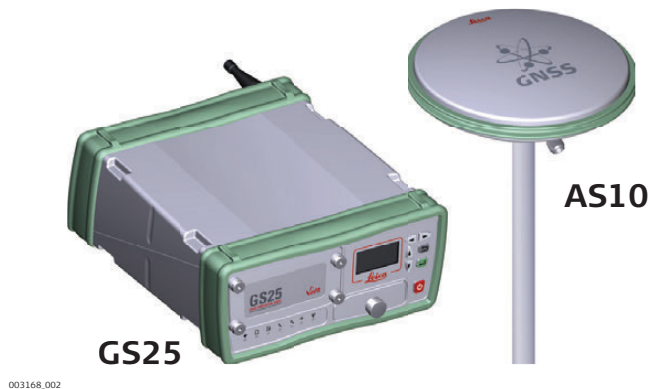

2.2 System Components

Main components

Component	Description
Instrument	To calculate a position from the computed ranges to all visible GNSS (Global Navigation Satellite System) satellites.
Web server	Web-based tool to preprogram the GNSS instrument.
Antenna	To receive the satellite signals from the GNSS satellites.
Leica Geo Office, Leica Infinity	The office software including a series of help programs which support working with Leica instruments.

Instrument

Depending on the satellite systems and signals configured, a maximum number of 120 channels is allocated.

Instrument	Description
GS25	GPS, GLONASS, BeiDou and Galileo GNSS receiver, triple frequency, SBAS (EGNOS, WAAS, GAGAN, MSAS, QZSS), code and phase, real-time capable, with event and PPS ports

2.3

System Concept

2.3.1

Software Concept

Description

All instruments use the same software concept.

Software for all GS GNSS instruments

Software type	Description
GS firmware (GS_xx.fw)	This important software covers all functions of the instrument. The Web server application is integrated into the firmware and cannot be deleted. The English language is integrated into the firmware and cannot be deleted.
Language software (WEB_LANG.sxx)	Numerous languages are available for the Web server application. The English language is the default language. One language is chosen as the active language.

Software upload



Uploading GS firmware can take some time. Ensure that the battery is at least 75% full before beginning the upload, and do not remove the battery during the upload process.

Software for	Description
All GS models	The software can be uploaded using the Leica Web server application or myWorld@Leica Geosystems.  Ensure that a Leica SD card is inserted into the GS instrument before starting the upload. Refer to "4.3 Working with the Memory Device".

2.3.2

Power Concept

General

Use the batteries, chargers and accessories recommended by Leica Geosystems to ensure the correct functionality of the instrument.

Power options

Power for the instrument can be supplied either internally or externally. Up to two external power supplies can be connected.

Internal power supply:

One GEB242 battery fit into the instrument.

External power supply:

GEB371 battery connected via a cable.

OR

Car battery connected via a converter cable supplied by Leica Geosystems.

OR



10.5 V-28 V DC power supply via a converter cable supplied by Leica Geosystems.

OR

110 V/240 V AC to 12 V DC power supply unit, supplied by Leica Geosystems.



For permanent operations use **Uninterruptible Power Supply** units as a back-up in a main power failure.

Description	Data (Leica GNSS raw data and RINEX data) can be recorded on the SD card.
Memory device	<p>SD card: All GS GNSS instruments have an SD card slot fitted as standard. An SD card can be inserted and removed. Available capacity: 1 GB.</p> <p> While other SD cards can be used, Leica Geosystems recommends to only use Leica SD cards and is not responsible for data loss or any other error that can occur while using a non-Leica card.</p>
	<p>Unplugging connecting cables, removing the data storage device or interrupting the power supply during the measurement can cause loss of data. Only remove the data storage device, unplug connecting cables or interrupt the power supply when the GS GNSS instrument is switched off.</p>
	<p>SD cards can directly be used in an OMNI drive as supplied by Leica Geosystems. Other PC card drives can require an adaptor.</p>

2.4

Container Contents

Container for GS25 instrument and accessories part 1 of 2

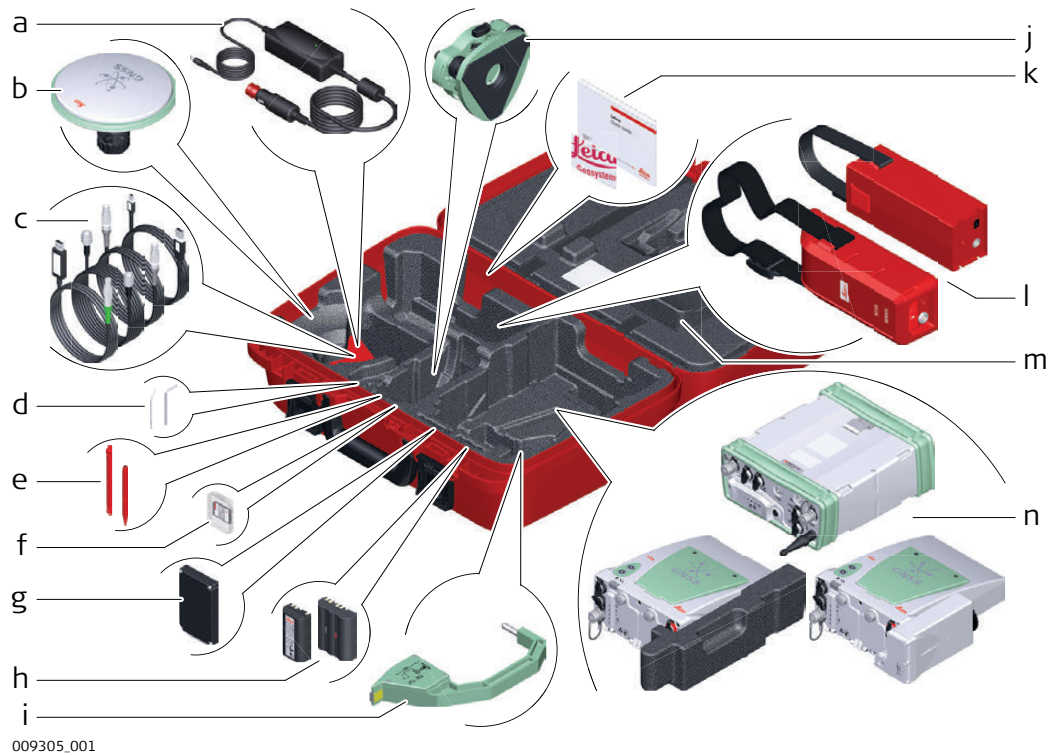

009305_001

- a) GDC221 car adapter cable
- b) Antenna and GAD31 adapter
- c) Cables
- d) Adjustment tool and allen key
- e) Stylus
- f) SD card and cover
- g) RTK phone or radio modem
- h) GEB212 or GEB311 battery
- i) Height hook
- j) Tribrach
- k) Manual & USB documentation card
- l) External battery
- m) Additional foam inlay piece (to be used with GS10 only)
- n) GS25 instrument

**Container for GS25
instrument and
accessories part 2
of 2**

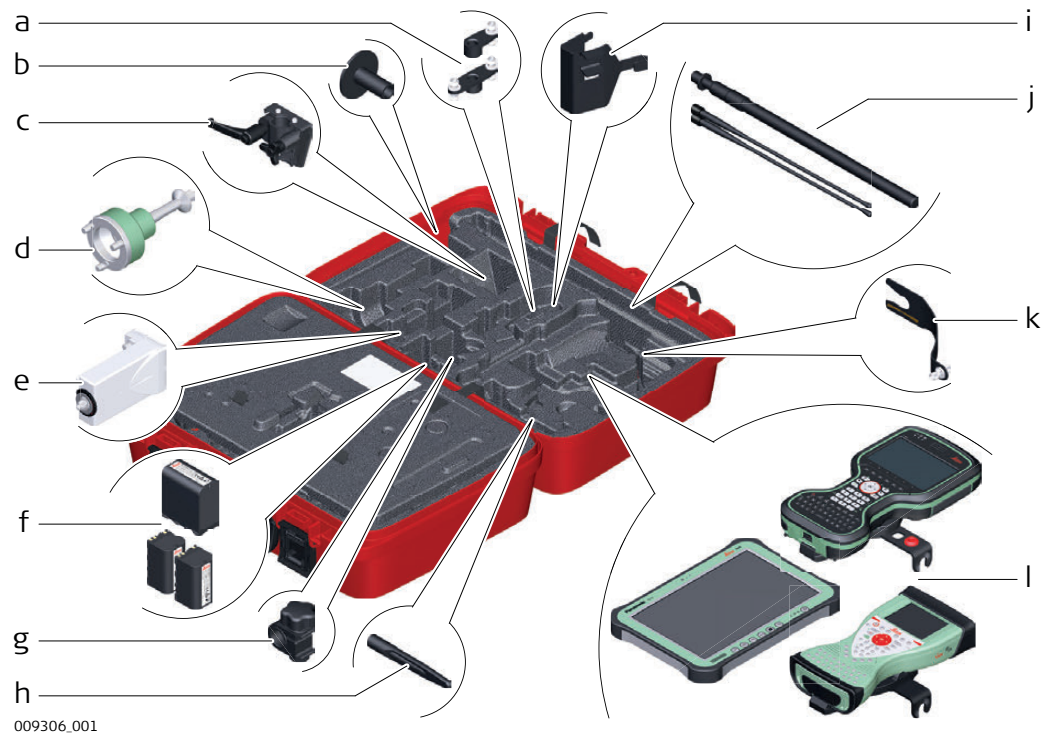

009306_001

- a) GAD34 antenna arm or GAD46 double antenna arm
- b) GHT36 base for telescopic rod
- c) GHT40 holder for GS receivers
- d) GRT146 carrier
- e) GFU RTK modem
- f) GEB242 battery or GEB222 batteries (2pcs.)
- g) GHT63 clamp
- h) GAT18 mobile antenna
- i) GHT58 tripod bracket for GFU
- j) GAD32 telescopic rod and GAT1 or GAT2 radio antennas
- k) GAD33 arm 15 cm
- l) CS35 tablet or CS20 field controller with GHT66 holder or CS15 field controller with GHT62 holder

2.5

Instrument Components



The instrument can be preprogrammed using the Web server application running from the instrument on a web browser of a Windows device. In this case, the instrument is turned on by holding down the power key for 3 s or off by holding down the power key for 3 s. A green steady light at the power LED indicates that the instrument is turned on.

GS25 components

1/2

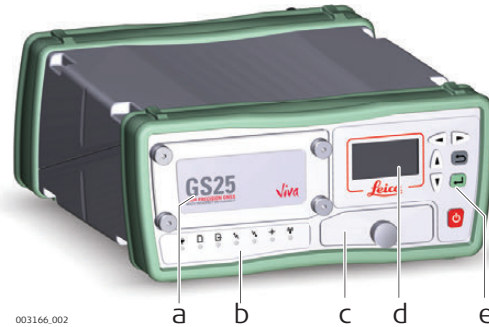

003166.002

- a) Battery compartment
- b) LED indicators
- c) Compartment with SD card slot, USB A Host port and USB Mini port
- d) Display
- e) Keyboard

GS25 components

2/2



003167.002

- a) GNSS antenna port
- b) Bluetooth antenna
- c) Port PPS
- d) LEMO port P4 and E2 (event input 2)
- e) LEMO port P2
- f) Port E1 (event input 1)
- g) LEMO port P1
- h) Power port
- i) RTK device antenna port
- j) RTK device compartment



A Bluetooth port is included inside the GS25 GNSS instrument to enable connectivity to the field controller.

3 User Interface

3.1 Keyboard

Keyboard GS25





- a) Left button
- b) Right button
- c) Up button
- d) ESC button
- e) Down button
- f) Enter button
- g) Display
- h) ON/OFF button

ON/OFF button

Key	Function
ON/OFF 	If GS25 already off: Turns on GS25 when held for 3 s. While the GS25 is booting all LEDs are lighted. Once the GS25 has started, the normal LED behaviour starts. If GS25 already on: Turns off GS25 when held for 3 s. All LEDs will shine red for 1 s-2 s and then are turned off.

Arrow buttons

Button	Function
Left/Right  Up/Down 	To scroll through menus and configuration options. For editable fields use the arrow buttons for scrolling and selecting alphanumeric fields.

Cancel button

Button	Function
Cancel 	To exit pages without storing changes.

Enter button

Button	Function
Enter 	To select menu items, open new pages and select options.

Operating the instrument

The GS25 GNSS instrument is operated either by pressing its keys or by the CS field controller.

Operation by keys

The GS25 GNSS instrument is operated by pressing its keys. Refer to "3.1 Keyboard" for a detailed description of the keys and their function.

Operation by CS field controller

The GS25 GNSS instrument is operated by the CS field controller using the Leica Captivate software. Refer to the Leica CS10/CS15 User Manual or Leica Viva GNSS Getting Started Guide for a detailed description of the keys and their function.

Turn on GS25

To turn on the instrument press and hold the power key for 3 s.

Turn off GS25

To turn off the instrument:

- press and hold the power key for 3 s
 - confirm to power down the instrument when exiting Leica Captivate software on the CS10/CS15 field controller
-

3.3

Working with the User Interface

Description of the Main Menu functions

Main Menu function	Description
Status	To check the current Position, the current Tracking status and the current Power/Memory status of the GNSS instrument.
Configuration	To switch the USB device Port (Port1/Mini USB).
Tools	To format the data storage device, System RAM, Windows CE registry, to stop the USB device or to initialise the Measurement Engine (ME) of the GNSS instrument.

3.3.1

Status Functions





Description

In the Status menu you can check the current Position, the current Tracking status and the current Power/Memory status of the GS25 GNSS instrument. All fields are display only fields. Unavailable information is indicated by "---".



Access

Step	Description
1.	Turn on the GS25 GNSS instrument. Refer to "Turn on GS25".
2.	 Select Main Menu: Status and press the Enter button to enter the Status menu.



Check current Position step-by-step

Step	Description
1.	 Enter the Status menu, select Position and press the Enter button.
2.	 Select Base/Rover and press the Enter button again.
3.	 The current position is displayed. Use the Left/Right button to toggle between WGS84 coordinates and Cartesian coordinates.
4.	 Press the Cancel button to return to the Position menu.

Check current Tracking step-by-step



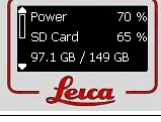

Step	Description
1.	 <p>Enter the Status menu, select Tracking and press the Enter button.</p>
2.	 <p>The current tracking status of the satellite systems configured is displayed. Use the Up/Down buttons to toggle between the different satellite systems.</p>
3.	 <p>Press the Cancel button to return to the Status menu.</p>

Check current Power/Memory step-by-step

Step	Description
1.	 <p>Enter the Status menu, select Power/Memory and press the Enter button.</p>
2.	 <p>The current Power/Memory status is displayed.</p>
3.	 <p>Press the Cancel button to return to the Status menu.</p>

Switch USB device port step-by-step

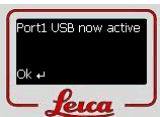
 The USB device port can be switched between **Port1** and **Mini USB**.

Step	Description
1.	Turn on the GS25 GNSS instrument. Refer to "Operating Principles".
2.	 Select Main Menu: Configuration and press the Enter button.
3.	 Select USB device Port and press the Enter button.
4.	 Select the USB device port you want to switch to (Port1/Mini USB) and press the Enter button.
5.	 The USB device port selected is activated.
6.	 Press the Enter button again to return to the Main Menu .

Description



Tools Menu function	Description
Format SD card	The format the SD card of the GNSS instrument.
Format USB device	To format a USB device connected to the GNSS instrument.
Format System	To format the System RAM of the GNSS instrument. Settings of all installed software are deleted.
Format Registry	To delete registry of the GNSS instrument (resets Windows CE and communication settings to factory defaults).
Stop USB device	To stop a USB device connected to the GNSS instrument. After the USB device has been stopped, it can be safely removed from the GNSS instrument.
Initialize ME	The current almanacs stored on the GNSS instrument are deleted and new almanacs are downloaded.



Access

Step	Description
1.	Turn on the GS25 GNSS instrument. Refer to "Turn on GS25".
2.	Select Main Menu: Tools and press the Enter button. 



Format SD card step-by-step

The different formatting options are similar. The individual steps do not differ between the different formatting options. As an example, the following example explains how to format an SD card.



-  Formatting a data storage device before storing data on it, is required if the device is new, or if all data on the device must be deleted.
-  By activating the format command all data will be lost. Make sure that all important data on the device has been backed up before formatting.

Step	Description
1.	Enter the Tools menu, select Format SD card and press the Enter button. 
2.	Press the Enter button again to continue with formatting the SD card or press the Cancel button to return directly to the Tools menu. 
3.	Once the formatting of the SD card is completed, the GS25 GNSS instrument is rebooted and you return to the Main Menu . 

Stop USB device step-by-step

Step	Description
1.	 <p>Enter the Tools menu, select Stop USB device and press the Enter button.</p>
2.	 <p>The USB device connected to the GNSS instrument is stopped. Now you can safely remove the USB device.</p>
3.	 <p>Press the Enter button again to return directly to the Tools menu.</p>

Initialize ME step-by-step

Step	Description
1.	 <p>Enter the Tools menu, select Initialize ME and press the Enter button.</p>
2.	 <p>Press the Enter button again to continue with initialising the ME or press the Cancel button to return directly to the Tools menu.</p>
3.	 <p>Once the initialising of the ME is completed, the GS25 GNSS instrument is rebooted and you return to the Main Menu.</p>

4

Operation

4.1

Equipment Setup

4.1.1

Setting up as a Post-Processing Base

Use

The equipment setup described is used for static operations over markers.

Description

The instrument can be programmed with the field controller before use which can then be omitted from the setup.



- The antenna is mounted directly using screw fitting. If using stub and adapter, procedures can vary slightly.
 - When using the adapter and carrier, ensure that the antenna and the adapter assembly slide down the full length of the carrier stub. An incorrectly mounted antenna will have a direct effect on the results.
-



If the instrument is left in the container during use in high temperatures, the lid should be left open. Refer to the User Manual for operating and storage temperatures.



Use an external battery such as GEB371 to ensure operation for a full day.

Equipment setup - GS25

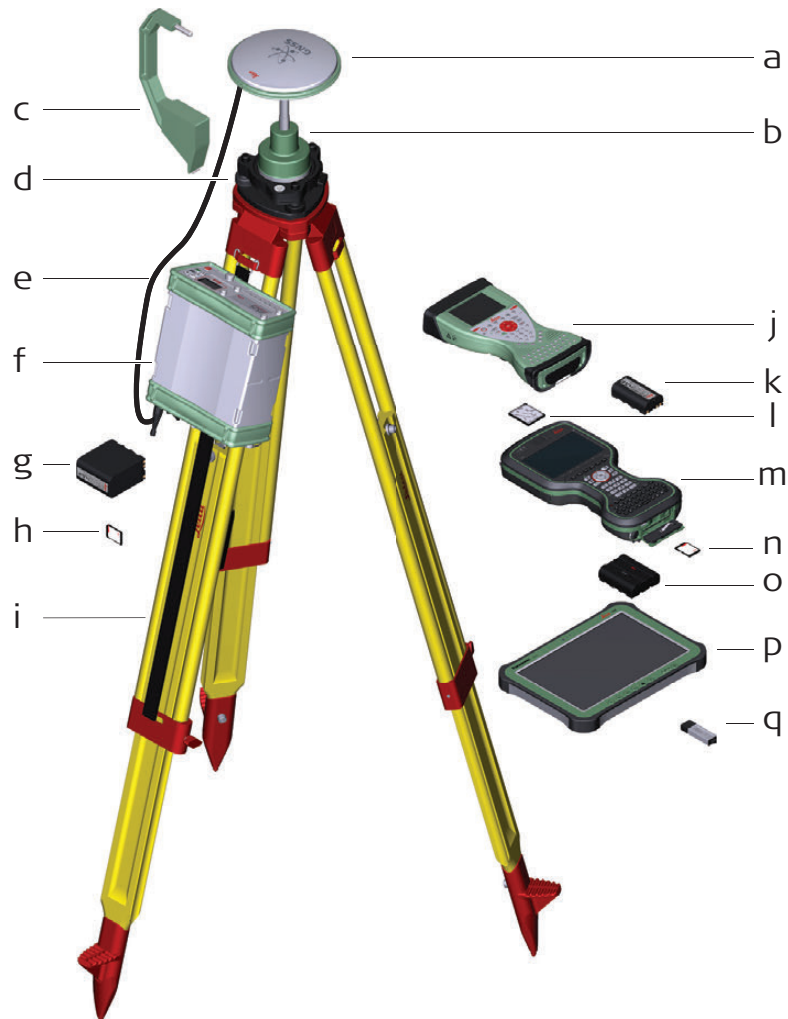

0012219_001

- a) GNSS antenna AS05/AS10
- b) GRT146 carrier
- c) Height hook
- d) Tribrach
- e) 1.2 m antenna cable
- f) GS25 instrument
- g) Tripod
- h) GEB242 battery
- i) SD card
- j) CompactFlash card
- k) CS field controller
- l) GEB212 battery

Equipment setup step-by-step

Step	Description	
1.	Set up the tripod.	
2.	Mount and level the tribrach on the tripod.	
3.	Ensure that the tribrach is over the marker.	
4.	Place and lock the carrier in the tribrach.	
	GS10/GS25	GS08plus/GS12/GS14/GS16/GS15
5.	Screw the GNSS antenna onto the carrier.	Insert the data storage device (only GS14/GS16/GS15) and the batteries into the GS08plus/GS12/GS14/GS16/GS15.
6.	Check that the tribrach is still level.	Screw the GS08plus/GS12/GS14/GS16/GS15 onto the carrier.
7.	Insert the batteries into the instrument.	Check that the tribrach is still level.
8.	Insert the SD card into the instrument.	Insert the data storage device and the battery into the CS field controller.
9.	Connect the instrument to the GNSS antenna using the antenna cable and port ANT on the instrument.	-
10.	Switch on the CS field controller and connect it to the instrument if necessary.  Mandatory for the GS08plus/GS12 and optional for the GS10/GS14/GS16/GS15/GS25.	
11.	To hang the instrument on the tripod leg, use the hook on the rear of the unit. Or place the instrument in the container.	To hang the CS field controller on the tripod leg, use the hook on the hand strap. Refer to the CS User Manual.
12.	Insert the height hook into the carrier.	
13.	Measure the antenna height using the height hook.	
14.	Press the ON/OFF button on the instrument for at least 2 s (GS25: 3 s) to switch on the instrument .	

Use

The equipment setup described is used for real-time base stations with the need of optimal radio coverage. Raw observation data can also be collected for post-processing.

Description

The GS10/GS25 instrument clips to the tripod leg. Connections are made to the GNSS and radio antenna. The radio antenna is mounted on the antenna arm which clips to the GNSS antenna. The GS10/GS12/GS14/GS16/GS15/GS25 instrument can be programmed with the CS field controller before use which can then be omitted from the setup.

The GS10/GS25 instrument can be used as a DGPS base station, if fitted with the DGPS option, and as a real-time base station.

The connection between GS14/GS16/GS15 and CS field controller is made via Bluetooth.



- The antenna is mounted directly using screw fitting. If using stub and adapter, procedures can vary slightly.
- When using the adapter and carrier, ensure that the antenna and the adapter assembly slide down the full length of the carrier stub. An incorrectly mounted antenna will have a direct effect on the results.
- Standard radio is used throughout the instructions. Digital cellular phones can also be used but the setup can differ slightly.



If the instrument is left in the container during use in high temperatures, the lid should be left open. Refer to the User Manual for operating and storage temperatures.



Use an external battery such as GEB371 to ensure operation for a full day.

Equipment setup - GS25

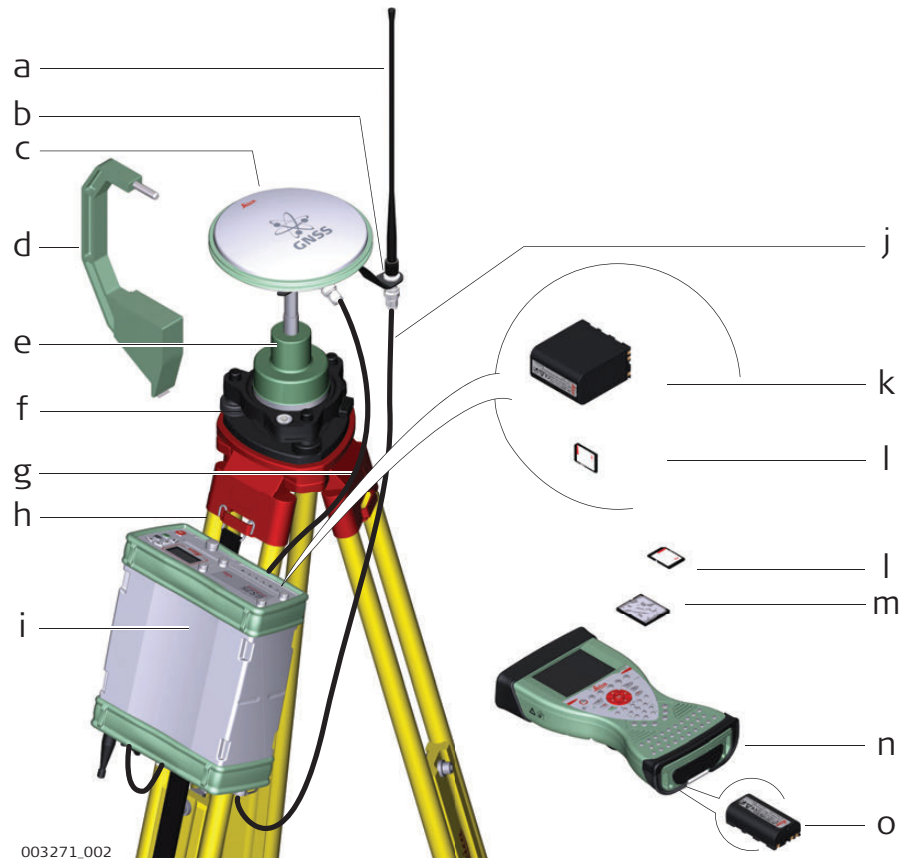

- 003271_002
- a) Radio antenna
 - b) GAD33 arm 15 cm
 - c) GNSS antenna AS05/AS10
 - d) Height hook
 - e) GRT146 carrier
 - f) Tribrach
 - g) 1.2 m antenna cable (instrument/GNSS antenna)
 - h) Tripod
 - i) GS25 instrument
 - j) 1.2 m antenna cable (radio housing/radio antenna)
 - k) GEB242 battery
 - l) SD card
 - m) CompactFlash card
 - n) CS field controller
 - o) GEB212 battery

Equipment setup step-by-step

Step	Description		
1.	Set up the tripod.		
2.	Mount and level the tribrach on the tripod.		
3.	Ensure that the tribrach is over the marker.		
4.	Place and lock the carrier in the tribrach.		
	GS10/GS25	GS08plus/GS12/ GS14/GS16 with external RTK device	GS14/GS16/GS15
5.	Screw the GNSS antenna onto the carrier.	Screw the GS08plus/GS12/ GS14/GS16 onto the carrier.	Insert the data storage device and the batteries into the GS14/GS16/GS15.
6.	Check that the tribrach is still level.		Press the ON/OFF button on the instrument for at least 2 s to switch on the instrument.
7.	Insert the SD card and the batteries into the instrument.	Hang the external battery onto a tripod leg.	Screw the GS14/GS16/GS15 onto the carrier.
8.	Connect the instrument to the GNSS antenna using the antenna cable and port ANT on the instrument.	Hang the tripod bracket onto a tripod leg and attach the radio housing onto the tripod bracket.	Check that the tribrach is still level.
9.	Connect the CS field controller to the instrument if necessary.	Connect the GEV205 cable to the GS08plus/GS12 or the GEV264 cable to the GS14/GS16, to the external battery and to the radio housing.	Insert the SD card or CompactFlash card and the battery into the CS field controller.
10.	To hang the instrument on the tripod leg, use the hook on the rear of the unit. Or place the instrument in the container.	Insert the SD card or CompactFlash card and the battery into the CS field controller.	Connect the CS field controller to the instrument if necessary.
11.	Insert the height hook into the carrier.	Connect the CS field controller to the instrument if necessary.	To hang the CS field controller on the tripod leg, use the hook on the hand strap. Refer to the CS User Manual.
12.	Measure the antenna height using the height hook.	To hang the CS field controller on the tripod leg, use the hook on the hand strap. Refer to the CS User Manual.	Insert the height hook into the carrier.
13.	Clip the antenna arm to the GNSS antenna.	Insert the height hook into the carrier.	Measure the antenna height using the height hook.

Step	Description		
14.	Screw the radio antenna onto the antenna arm.	Measure the antenna height using the height hook.	Press the ON/OFF button on the instrument for at least 2 s to switch on the instrument.
15.	GS10 Attach the radio in its housing to port P2 or P3 on the instrument. GS25 Insert the slot-in radio into port P3 on the instrument.	Press the ON/OFF button on the instrument for at least 2 s to switch on the instrument.	-
16.	Connect the radio antenna to the radio using the second 1.2 m antenna cable.	-	-
17.	Press the ON/OFF button on the instrument for at least 2 s (GS25: 3 s) to switch on the instrument.	-	-

Use

The equipment setup is used for real-time rover with extended periods of use in the field.

Description

The radio attaches to the instrument (GS10) or is inserted into the instrument (GS25) and is placed in the backpack. Connections are made to the GNSS antenna, radio antenna and CS field controller. The cables coming from the backpack can be disconnected when an obstacle such as a fence has to be crossed.

The CS field controller is fixed to the pole with the GHT62. Connection between the GS12/GS14/GS16/GS15/GS08plus instrument and the CS field controller is made through Bluetooth.



- The antenna is mounted directly using screw fitting. If using stub and adapter, procedures can vary slightly.
 - When using the pole with stub, ensure that the antenna and the screw-to-stub adapter slide down the full length of the stub before tightening the locking ring. An incorrectly mounted antenna will have a direct effect on the results.
 - Aluminium poles are used. They can be replaced with their carbon fibre equivalent without any change to these instructions.
 - Standard radio is used throughout the instructions. Digital cellular phones can also be used but the setup can differ slightly.
-

Equipment setup - GS25

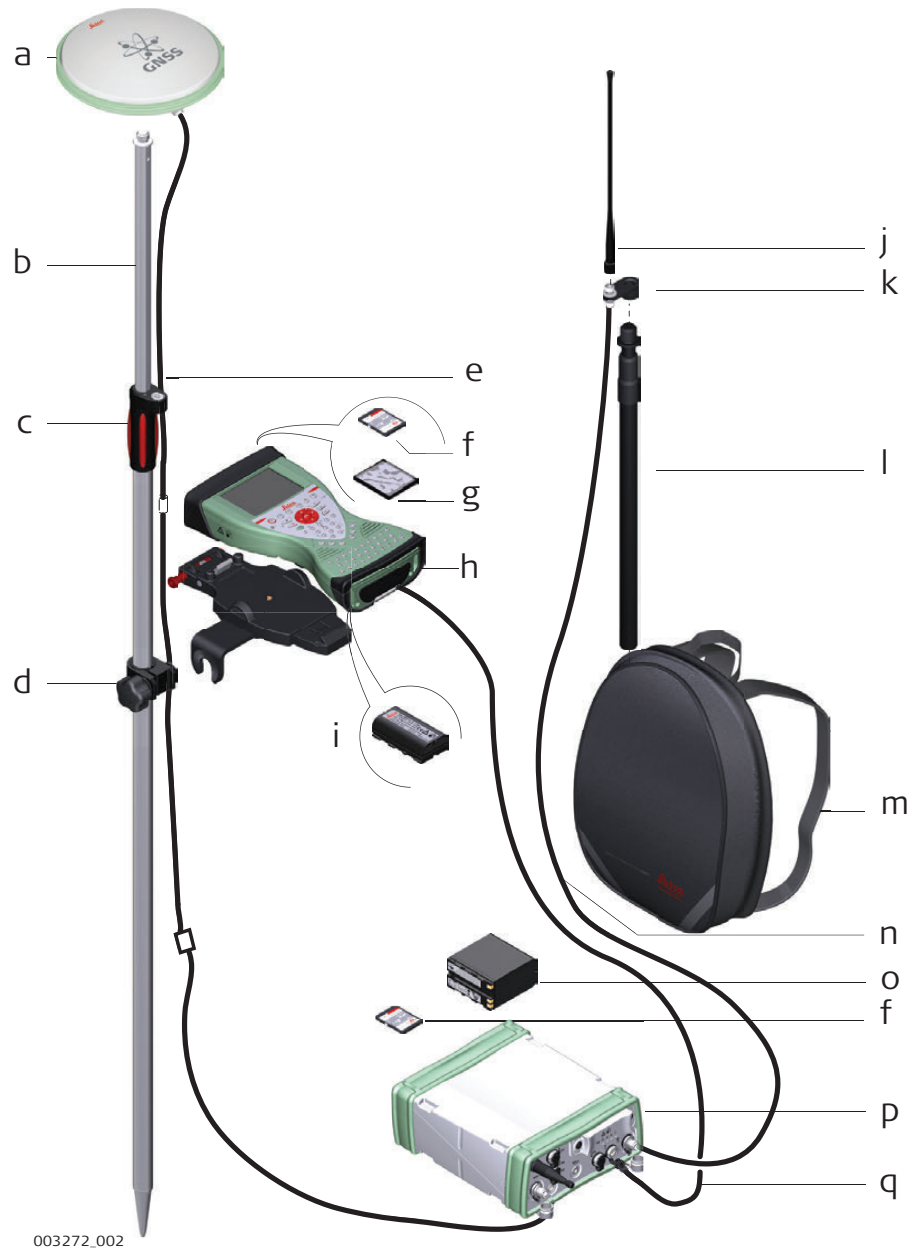

003272_002

- a) GNSS antenna AS05/AS10
- b) Pole
- c) CS field controller
- d) Grip for pole
- e) GHT62 holder
- f) Antenna cable
- g) SD card
- h) CompactFlash card
- i) GEB212 battery
- j) Radio antenna
- k) GAD34 arm 3 cm
- l) Telescopic rod
- m) Backpack
- n) 1.2 m antenna cable (radio housing - radio antenna)
- o) GEB242 battery
- p) GS25 instrument
- q) 1.8 m, CS to GS25 cable

Equipment setup step-by-step

Step	Description
1.	Attach the GHT62 holder to the pole.
2.	Insert the SD card or CompactFlash card and the battery into the CS field controller.
3.	 For real-time setup with radio: Attach the CGR radio to the CS field controller. Refer to the CS User Manual.
4.	Clip the CS field controller into the holder and lock it by pushing the locking pin into the locked position.
5.	Press ON/OFF button on the CS field controller to switch on.
	Proceed with step 6. for GS10/GS25 and with step 25. for GS12/GS14/GS16/GS15/GS08plus.
6.	Screw the GNSS antenna to the top of the pole.
7.	Insert the SD card and the batteries into the instrument.
8.	GS10 Attach the radio in its housing to port P2 or P3 on the instrument. GS25 Insert the slot-in radio into port P3 on the instrument.
9.	Place the instrument in the backpack with the top side facing outwards and the instrument front panel to the top.
10.	Fasten the strap around the instrument.
11.	Push the telescopic rod through the slit in the top of the backpack. Ensure that it is located in the sleeve inside the backpack and push it all the way to the bottom.
12.	Adjust the height of the telescopic rod to suit.
13.	Screw the radio antenna arm onto the telescopic rod.
14.	Connect the first 1.2 m antenna cable to the radio antenna.
15.	Pass the cable through the opening in the top of the backpack and down underneath the instrument.
16.	Connect the first 1.2 m antenna cable to the radio.
17.	Connect the 1.6 m antenna cable to port ANT on the instrument.
18.	Pass the 1.6 m antenna cable through a cable brake and down through the opening in the bottom corner of the backpack flap.
19.	Draw the required amount of cable out of the backpack and tighten the cable brake.
20.	Connect one end of the second 1.2 m antenna cable to the loose end of the 1.6 m antenna cable and the other end to the GNSS antenna.
21.	Connect the 1.8 m, CS to GS cable to the CS field controller.
22.	Pass the 1.8 m, CS to GS cable through the opening in the bottom corner of the backpack flap and up through a cable brake.
23.	Plug it into port P1 on the instrument.
24.	Press ON/OFF button on the instrument to switch on.
	GS12/GS14/GS16/GS15/GS08plus.
25.	Insert the data storage device (only GS14/GS16/GS15) and the batteries into the GS12/GS14/GS16/GS15/GS08plus.
26.	Press ON/OFF button on the GS12/GS14/GS16/GS15/GS08plus to switch on.
27.	Screw the GS12/GS14/GS16/GS15/GS08plus to the top of the pole.
28.	CS field controller and GS12/GS14/GS16/GS15/GS08plus are connected via Bluetooth.

Position of cables in the backpack

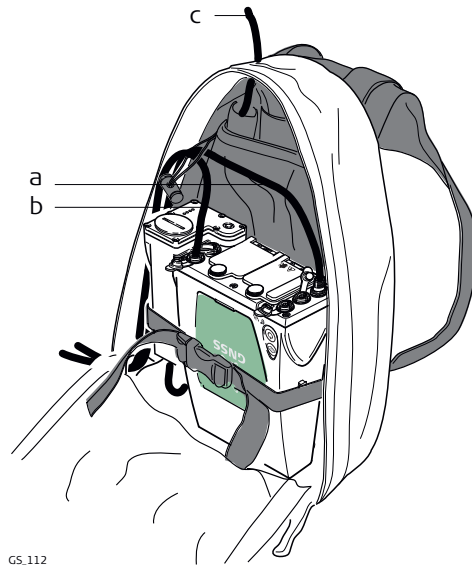

GS_112

- a) 1.6 m antenna cable
- b) 1.8 m cable to connect field controller and GS instrument
- c) 1.2 m antenna cable to connect radio housing and radio antenna

4.1.4 Using the Backpack

Use

The backpack is used for various applications. The applications are:

- Post-processed kinematic, pole and backpack.
- Real-time rover, pole and backpack.

Antenna pole strap

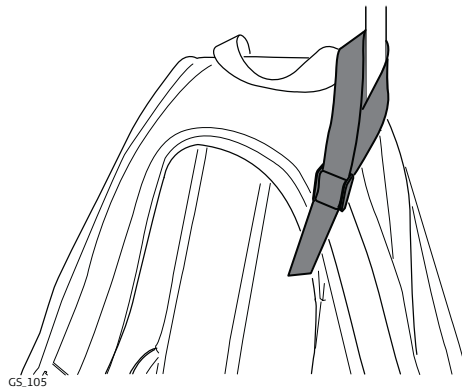

GS_105

Ensures that the antenna pole does not sway around and remains as upright as possible.

Pass the strap around the pole and fasten using the clip as shown in the diagram.

Hip belt



GS_102

The hip belt

- transfers most of the weight from the shoulders to the hips when properly adjusted.
- contains velcro attachments through which cables can be passed.

Internal net pouch

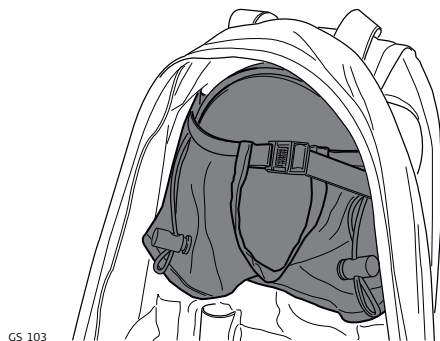

- The internal net pouch is designed for
- carrying an AS05/AS10 antenna when not in use.
 - storing coiled cables.
 - carrying a non-standard radio.
 - carrying spare batteries.
 - carrying sandwiches.

Use in high temperatures

In high temperatures, it is desirable to increase air flow around the instrument. Therefore the backpack can be kept half or even fully open when in use.



- To half open the backpack:
- 1) Open the backpack halfway.
 - 2) Tuck the flap inside.
 - 3) Secure it with the velcro pad.



- To open the backpack completely:
- 1) Open the backpack completely.
 - 2) Secure it with the velcro pad.
 - 3) Tuck the flap under the instrument.

4.1.5

Fixing the Field Controller to a Holder and Pole



This chapter is valid for all holders.

Components of the GHT66 Holder

The GHT66 holder consists of the following components:



GHT63 clamp

- a) Plastic sleeve
- b) Pole clamp
- c) Clamp bolt

GHT66 holder

- d) Locking pin
- e) Top clip
- f) Mounting plate
- g) Bottom clip
- h) Tightening screw
- i) Mounting arm

Fixing the Field Controller and GHT66 to a Pole Step-by-step

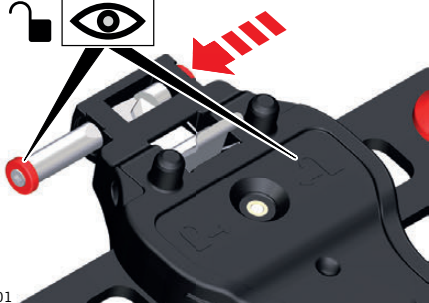
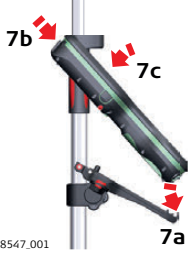
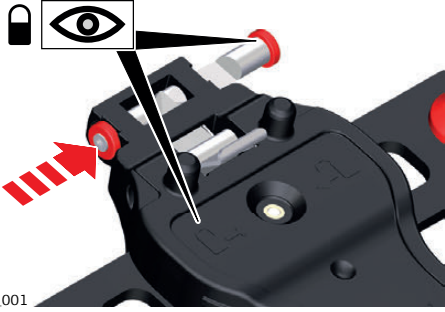
Step	Description
	For an aluminium pole, fit the plastic sleeve to the pole clamp.
1.	Insert the pole into the clamp hole.
2.	Attach the holder to the clamp using the clamp bolt.
3.	Adjust the angle and the height of the holder on the pole to a comfortable position.
4.	Tighten the clamp with the clamp bolt.
5.	Before placing the CS field controller onto the mounting plate, ensure that the locking pin is put into the unlocked position. To unlock the locking pin, push the locking pin to the left.
	
6.	Hold the CS field controller above the holder and lower the end of the CS field controller into the mounting plate.
7.	Apply slight pressure in a downward direction and then lower the top part of the CS field controller until the unit is clicked into the holder. The guides of the mounting plate aid in this action.
	
8.	After the CS field controller is placed onto the mounting plate, ensure that the locking pin is put into the locked position. To lock the locking pin, push the locking pin to the right.
	

Detaching the Field Controller from a Pole Step-by-step

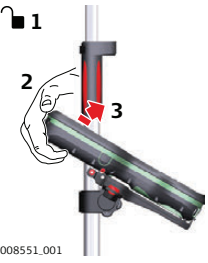
Step	Description
1.	Unlock the locking pin by pushing the locking pin to the left of the mounting plate.
2.	Place your palm over the top of the field controller.
3.	While in this position, lift the top of the field controller from the holder.
	

Description

Windows **M**obile **D**evice **C**enter for PCs with Windows 7/Windows 8/Windows 10 operating system is the synchronization software for Windows mobile-based pocket PCs. WMDC enables a PC and a Windows mobile-based pocket PC to communicate.

Leica USB drivers support Windows 7, Windows 8 (8.1) and Windows 10 operating systems.

Cables

Leica USB drivers support:



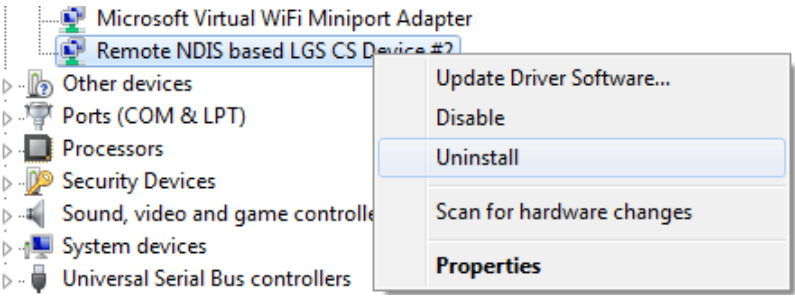
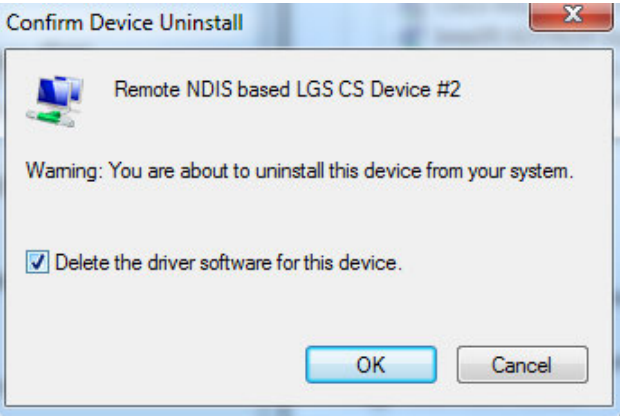

Name	Description
GEV223	USB data cable, 1.8 m, connects instrument to Mini-USB to USB
GEV234	USB data cable, 1.65 m, connects CS to GS or CS to PC (USB)
GEV261	Y-cable, 1.8 m, connects instrument to PC - battery

Uninstalling the previous drivers



 Skip the following steps if you have never installed Leica USB drivers before. If older drivers were previously installed on the PC, follow the instructions to un-install the drivers prior the installation of the new drivers.

Step	Description
1.	Connect your instrument to the PC via cable.
2.	On your PC, select to Control Panel > Device Manager .
3.	In Network Adapters , right-click on Remote NDIS based LGS....
4.	Click on Uninstall . 
5.	Set Delete the driver... as checked. Press OK . 

Install Leica USB drivers

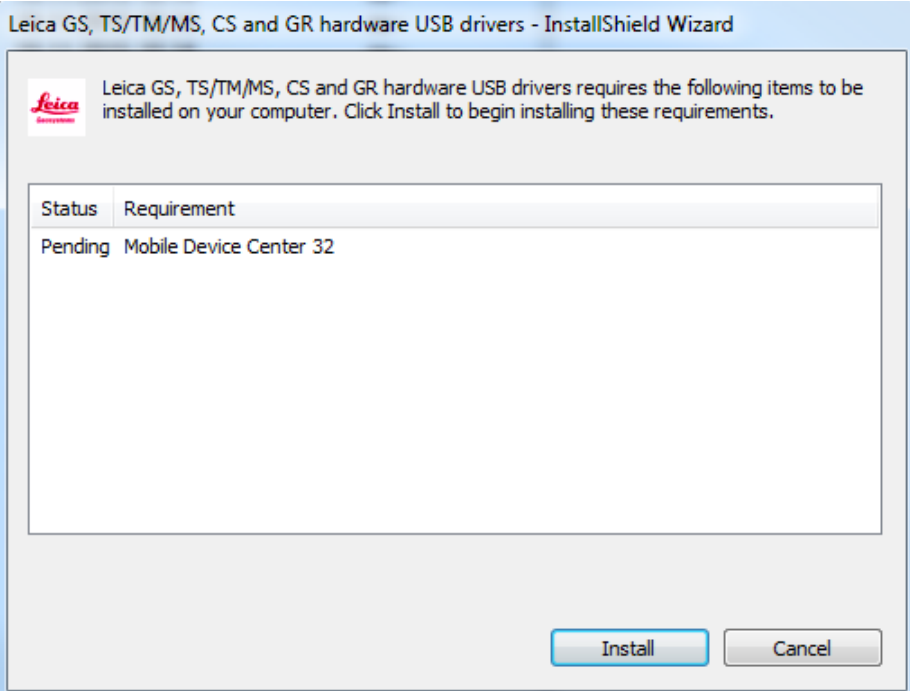
Step	Description
1.	Start the PC.
2.	<p>Run the Setup_Leica_USB_XXbit.exe to install the drivers necessary for Leica devices. Depending on the version (32bit or 64bit) of the operating system on your PC, you have to select between the three setup files following:</p> <ul style="list-style-type: none"> • Setup_Leica_USB_32bit.exe • Setup_Leica_USB_64bit.exe • Setup_Leica_USB_64bit_itanium.exe <p> To check the version of your operating system, go to Control Panel > System > System type.</p> <p> The setup requires administrative privileges.</p> <p> The setup has to be run only once for all Leicadevices.</p> <p> For PCs with Windows Vista/Windows 7/Windows 8/Windows 10 operating system: If not already installed, WMDC will be installed additionally otherwise this panel would not appear. Click Install to continue or Cancel to exit installation.</p>

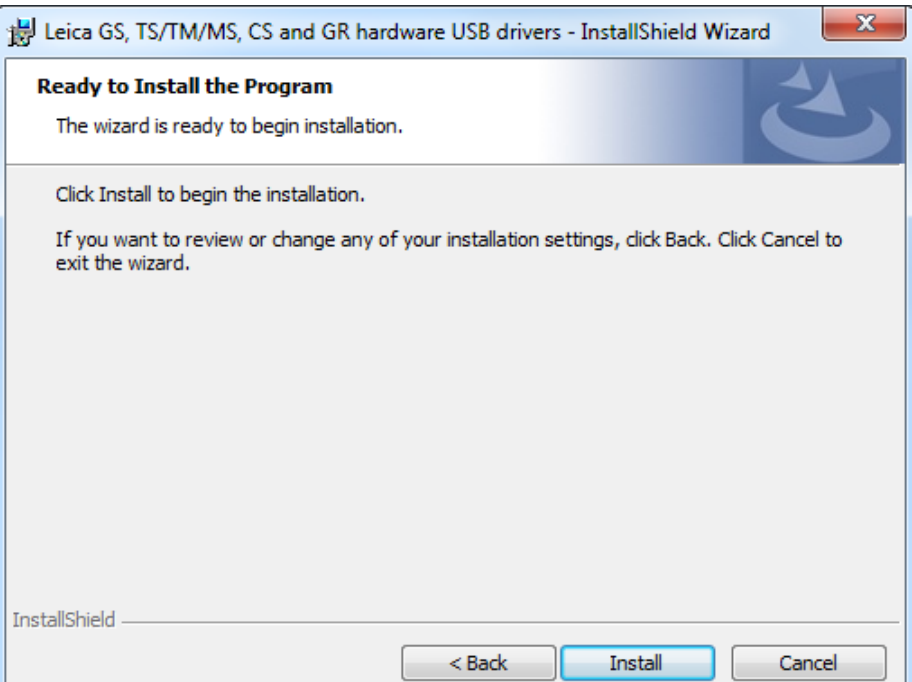

Step	Description
3.	<p>The Welcome to InstallShield Wizard for Leica GS, TS/TM/MS, CS and GR USB drivers window appears.</p> <p> Ensure that all Leica devices are disconnected from your PC before you continue!</p> 
4.	<p>Next>.</p>
5.	<p>The Ready to Install the Program window appears.</p> 
6.	<p>Install. The drivers will be installed on your PC.</p>
7.	<p>The InstallShield Wizard Completed window appears.</p>
8.	<p>Click Finish to exit the wizard.</p>

Connect to PC via USB cable step-by-step

Step	Description
1.	Start the PC.
2.	Plug the cable into the instrument.
3.	Turn on the instrument.
4.	Plug the cable into the USB port of the PC.  Windows Device Manager cannot be used with CS20/TS16/TS60/MS60.
5.	Press the Windows Start button at the bottom left corner of the screen.
6.	Type the IP address of the device into the search field. <ul style="list-style-type: none">• \\192.168.254.1\ for field controller• \\192.168.254.3\ for other instruments
7.	Press Enter . A file browser opens. You can now browse within the folders on the instrument.

4.1.7

Connecting to the Web Server

Description

The Web server is a web-based tool to view the status of and configure the GNSS instruments. The Web server application is integrated into the GS firmware and cannot be deleted.

Accessing the Web server via cable step-by-step

Step	Description
1.	Start the PC and turn on the GS GNSS instrument.  Instead of connecting to your PC, you can connect your GS GNSS instrument to the field controller.
2.	Connect the GS GNSS instrument with the GEV234 cable to the PC. Refer to "4.1.6 Connecting to a Personal Computer".
3.	Double-Click the Configure GS connection shortcut from the desktop of your PC. The GS GNSS network adapter is configured with IP address: 192.168.254.1. A DOS window appears when the configuration was successful. Press any key to exit the DOS window. The Configure GS connection shortcut disappears from the desktop.
4.	Start the web browser of your PC.
5.	Type in http://192.168.254.2 and press enter to access the web server of GS instrument.

Accessing the Web server via Bluetooth step-by-step

To access the Web server the tasks following have to be done:



- Configure the PC's Bluetooth device
- Establish a Bluetooth connection between PC and GS
- Accessing the Web server

Configuring the PC's Bluetooth device

Step	Description
1.	Start your PC.
2.	Activate the Bluetooth device of your PC.
3.	Go Start⇒Settings⇒Network Connections .
4.	Double-click Bluetooth from the LAN or High-Speed Internet device list. The Bluetooth Properties windows is started.

Step	Description
5.	In the General page, select Internet Protocol (TCP/IP) from the list and click Properties . The Internet Protocol (TCP/IP) properties windows is started.
6.	Set IP address: 192.168.253.1 and Subnet mask: 255.255.255.0 and click OK confirm the settings.
	This procedure has to be done only once.

Establishing a Bluetooth connection between PC and GS GNSS instrument

Step	Description
1.	Start the PC and turn on the GS GNSS instrument.  Instead of connecting to your PC, you can connect your GS GNSS instrument to the field controller. In this case, turn on the field controller, start Leica SmartWorx Viva/Leica Captivate and establish a Bluetooth connection to the GS GNSS instrument.
2.	Run the Bluetooth software and start the Bluetooth Setup Wizard .
3.	Click Next . The Bluetooth Device Selection will be started and an automatic search will be done.
4.	Select the shown GS GNSS instrument and click Next . The Bluetooth Security Setup is started.
5.	Type in 0000 as Bluetooth security code and click Pair Now . The pairing procedure will be done and the Bluetooth Service Selection is started.
6.	Highlight Personal Ad-hoc Network and check the checkbox for Personal Ad-hoc Network.  Do not select Serial Port as service.
7.	Click Next . The Bluetooth Setup Wizard Completion Page is started.
8.	Type in a name for your GS GNSS instrument and click Finish to complete the Bluetooth Setup Wizard .
	This procedure has to be repeated for every GS GNSS instrument you want to connect to.

Accessing the Web server

Step	Description
1.	Start the web browser on your PC/field controller.  Ensure that your GS GNSS instrument is still running and the Bluetooth connection between PC/field controller and GS is established.
2.	Type in 192.168.253.2 . The Web server is started. You will see the home functions following: <ul style="list-style-type: none"> • Go to Work! <ul style="list-style-type: none"> - To select and start the Wake-up application. • Current Status <ul style="list-style-type: none"> - To access GNSS information of the GS as well as the instrument firmware. • Instrument <ul style="list-style-type: none"> - To access configuration settings for the GS. • User <ul style="list-style-type: none"> - To upload and activate firmware, licence keys and languages.

4.2

Batteries

4.2.1

Operating Principles

First-time Use / Charging Batteries

- The battery must be charged prior to using it for the first time because it is delivered with an energy content as low as possible.
 - The permissible temperature range for charging is between 0°C and +40°C/+32°F and +104°F. For optimal charging, we recommend charging the batteries at a low ambient temperature of +10°C to +20°C/+50°F to +68°F if possible.
 - It is normal for the battery to become warm during charging. Using the chargers recommended by Leica Geosystems, it is not possible to charge the battery if the temperature is too high.
 - For new batteries or batteries that have been stored for a long time (> three months), it is effectual to make only one charge/discharge cycle.
 - For Li-Ion batteries, a single discharging and charging cycle is sufficient. We recommend carrying out the process when the battery capacity indicated on the charger or on a Leica Geosystems product deviates significantly from the actual battery capacity available.
-

Operation / Discharging

- The batteries can be operated from -20°C to +55°C/-4°F to +131°F.
 - Low operating temperatures reduce the capacity that can be drawn; high operating temperatures reduce the service life of the battery.
-



When the GS25 GNSS instrument is connected to an external power while the internal battery is inserted, the internal battery is automatically charged.

-  When the GS25 is turned on, the battery charging status is indicated in the GS25 Web server application.
When the GS25 is powered down, battery charging is indicated via the LEDs. Refer to "4.5 LED Indicators on GS25".
-

Change battery step-by-step



003171_002

Step	Description
	The battery is inserted in the front of the instrument.
1.	Loosen the screws of the battery compartment.
2.	Open the cover of the battery compartment.
3.	With the Leica logo facing leftward, slide the battery into the battery compartment and push so that it locks into position.
4.	Close the cover of the battery compartment and tighten the screws.
5.	To remove the battery, loosen the screws to open the cover of the battery compartment.
6.	Push the ledge on the right side of the battery compartment to the right until it releases the battery from its fixed position.
7.	Pull out the battery.
8.	Close the cover of the battery compartment and tighten the screws.

4.3

Working with the Memory Device



- Keep the card dry.
- Use it only within the specified temperature range.
- Do not bend the card.
- Protect the card from direct impacts.



Failure to follow these instructions could result in data loss and/or permanent damage to the card.

Insert and remove an SD card into GS25 step-by-step

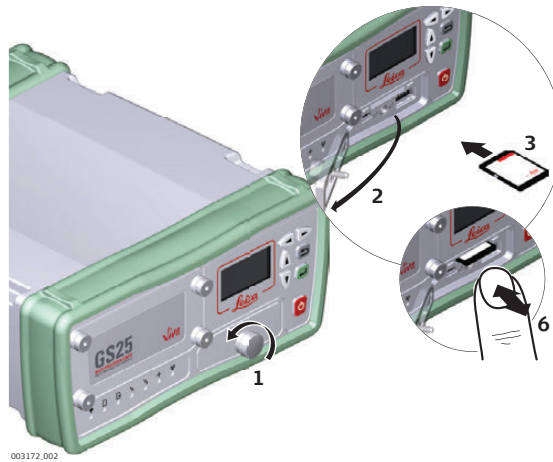

003172_002

Step	Description
	The SD card is inserted in the front of the instrument.
1.	Loosen the screw on the SD card compartment.
2.	Open the cover of the SD card compartment.
3.	Insert the card firmly into the slot until it clicks into position.
4.	Close the cover of the SD card compartment and tighten the screw.
5.	To remove the card, open the cover of the SD card compartment.
6.	Gently press on the top of the card to release it from the slot.
7.	Remove the SD card.
8.	Close the cover of the SD card compartment and tighten the screw.

Devices fitting into the GS25 GNSS instrument

Digital cellular phones fitting into the GS25 GNSS instrument



Digital cellular phone	Device
Telit UC864-G	SLG1-2

Radios fitting into the GS25 GNSS instrument

Radio	Device
SATELLINE M3-TR1, transceiver	SLR5-1
SATELLINE M3-TR4, transceiver	SLR6-1

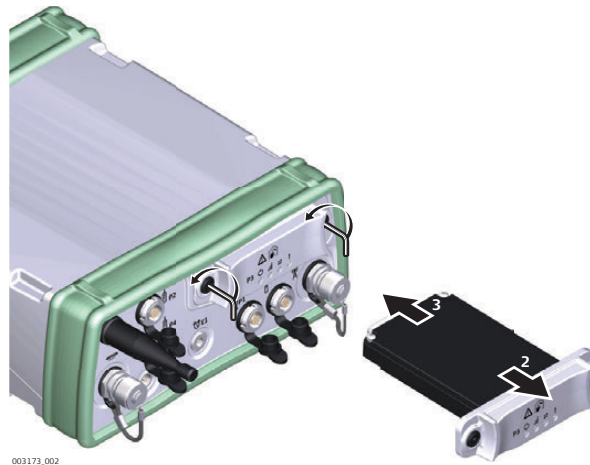
Insert and remove a slot-in-device step-by-step



Step	Description
1.	Loosen the screws of the compartment cover with the supplied Allen key.
2.	Remove the compartment cover.
3.	Attach the slot-in-device to the compartment cover.
4.	Insert the compartment cover into the compartment (port P3).
5.	Tighten the screws.  All screws have to be tightened to ensure that the instrument is waterproof.
6.	Attach the antenna for the slot-in device to RTK device antenna port. Refer to "Port PPS".
	For the equipment setup as real-time base station with radio, it's recommended to use an external radio antenna mounted on a second tripod. This increases the height of the radio antenna and therefore maximises radio coverage. Refer to the Leica Viva GNSS Getting Started Guide for detailed information about the setup.

Insert and remove a SIM card step-by-step

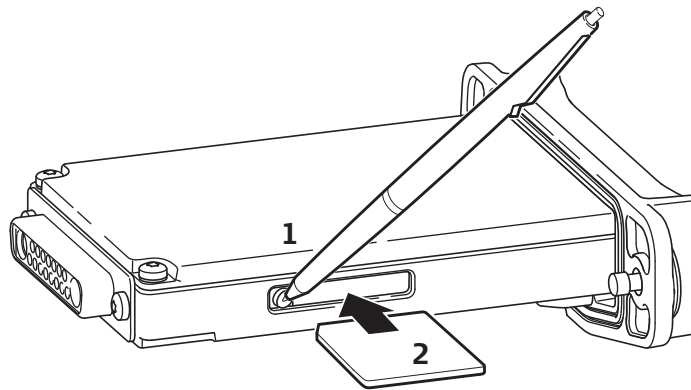

GR10_011

Step	Description
	The SIM card is inserted into a slot on the side of the SLG1-2.
	Take the SIM card and a pen.
1.	Using the pen, press the small button of the SIM card slot to eject the SIM card holder.
2.	Take the SIM card holder out off the SLG1-2.
3.	Place the SIM card into the SIM card holder, the chip facing up.
4.	Insert the SIM card holder into the SIM card slot, the chip facing the connectors inside the slot.

LED indicators

Description

Each slot-in-device for a radio or digital cellular phones has **Light Emitting Diode** indicators on the bottom side. They indicate the basic device status.

Diagram

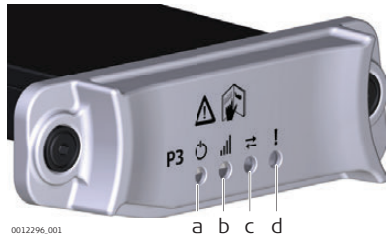

0012296_001

- a) Power LED
- b) Signal strength LED
- c) Data transfer LED
- d) Mode LED, available for Satellite 3AS

Description of the LEDs

IF the	on	is	THEN
Mode LED	SLR5 with SATELLINE M3-TR1	red	the device is in the programming mode controlled from the PC via cable.
Data transfer LED	any device	off	data is not being transferred.
		flashing green	data is being transferred.

IF the	on	is	THEN	
Signal strength LED	SLG1 with Telit UC864-G	red	call is in progress.	
		red: long flash, long break	no SIM card inserted, no PIN entered or network search, user authentication or network login in progress.	
		red: short flash, long break	logged on to network, no call in progress.	
		red: flashing red, long break	GPRS PDP context activated.	
		red: long flash, short break	Packet switched data transfer is in progress.	
		off	device is off.	
	SLR5-1 with SATELLINE M3-TR1 SLR6-1 with SATELLINE M3-TR4	red	the communication link, Data Carrier Detection , is okay on the roving instrument.	
		flashing red	the communication link, Data Carrier Detection , is okay on the roving instrument, but signal is weak.	
		off	the DCD is not okay.	
	Power LED	any device	off	power is off.
			green	power is okay.

LED indicators

Description

The GS25 GNSS instrument has Light Emitting Diode indicators. They indicate the basic instrument status.

Diagram

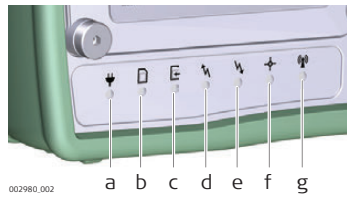

- a) Power LED
- b) Storage LED
- c) Raw data logging LED
- d) RTK Base LED
- e) RTK Rover LED
- f) Position LED
- g) Bluetooth LED

Description of the LEDs

IF the	is	THEN
Power LED	off	battery is not connected, flat or GS25 is switched off.
	green	power is 40%- 100%.
	yellow	power is 20%- 40%. The remaining time for which enough power is available depends on the type of survey, the temperature and the age of the battery.
	red	power is 5%- 20%.
	fast flashing red	power is low (< 5%).
Storage LED	off	no SD card is inserted or GS25 is switched off.
	green	SD card is inserted.
	flashing yellow	SD card is inserted but less than 10% memory left.
	flashing red	SD card is inserted but less than 5% memory left.
	red	SD card is inserted but full or SD card is unable to read.
Raw data logging LED	off	GS25 is not configured to log raw data.
	green	GS25 is configured to log raw data.
	flashing green	raw data is being logged.
	red	no raw data is being logged but GS25 is configured to log raw data.
RTK Rover LED	off	GS25 is in RTK base mode or GS25 is switched off.
	green	GS25 is in rover mode. No RTK data is being received at the interface of the communication device.
	flashing green	GS25 is in rover mode. RTK data is being received at the interface of the communication device.
RTK Base LED	off	GS25 is in RTK rover mode or GS25 is switched off.
	green	GS25 is in RTK base mode. No RTK data is being passed to the RX/TX interface of the communication device.

IF the	is	THEN
	flashing green	GS25 is in RTK base mode. Data is being passed to the RX/TX interface of the communication device.
Position LED	off	no satellites are tracked or GS25 is switched off.
	flashing yellow	less than four satellites are tracked, a position is not yet available.
	yellow	a navigated position is available.
	flashing green	a code-only position is available.
Bluetooth LED	green	a fixed RTK position is available. SmartLink is converging or has converged.
	purple	Bluetooth is in data mode and ready for connecting.
	blue	Bluetooth is connecting.
	blue	Bluetooth has connected.

4.6

Guidelines for Correct Results with GNSS Surveys

Undisturbed satellite signal reception

Successful GNSS surveys require undisturbed satellite signal reception, especially at the instrument which serves as a base. Set up the instrument in locations which are free of obstructions such as trees, buildings or mountains.

Steady instrument for static surveys

For static surveys, the instrument must be kept perfectly steady throughout the whole occupation of a point. Place the instrument on a tripod or pillar.

Centred and levelled instrument

Centre and level the instrument precisely over the marker.

5 Care and Transport

5.1 Transport

Transport in the field	<p>When transporting the equipment in the field, always make sure that you</p> <ul style="list-style-type: none">• either carry the product in its original transport container,• or carry the tripod with its legs splayed across your shoulder, keeping the attached product upright.
Transport in a road vehicle	<p>Never carry the product loose in a road vehicle, as it can be affected by shock and vibration. Always carry the product in its transport container, original packaging or equivalent and secure it.</p>
Shipping	<p>When transporting the product by rail, air or sea, always use the complete original Leica Geosystems packaging, transport container and cardboard box, or its equivalent, to protect against shock and vibration.</p>
Shipping, transport of batteries	<p>When transporting or shipping batteries, the person responsible for the product must ensure that the applicable national and international rules and regulations are observed. Before transportation or shipping, contact your local passenger or freight transport company.</p>

5.2 Storage

Product	<p>Respect the temperature limits when storing the equipment, particularly in summer if the equipment is inside a vehicle. Refer to "6 Technical Data" for information about temperature limits.</p>
Li-Ion batteries	<ul style="list-style-type: none">• Refer to "Technical Data" for information about storage temperature range.• Remove batteries from the product and the charger before storing.• After storage recharge batteries before using.• Protect batteries from damp and wetness. Wet or damp batteries must be dried before storing or use.• A storage temperature range of 0°C to +30°C / +32°F to +86°F in a dry environment is recommended to minimize self-discharging of the battery.• At the recommended storage temperature range, batteries containing a 40% to 50% charge can be stored for up to one year. After this storage period the batteries must be recharged.

5.3

Cleaning and Drying

Product and accessories

- Use only a clean, soft, lint-free cloth for cleaning. If necessary, moisten the cloth with water or pure alcohol. Do not use other liquids; these may attack the polymer components.
-

Damp products

Dry the product, the transport container, the foam inserts and the accessories at a temperature not greater than 40 °C [104 °F] and clean them. Remove the battery cover and dry the battery compartment. Do not repack until everything is dry. Always close the transport container when using in the field.

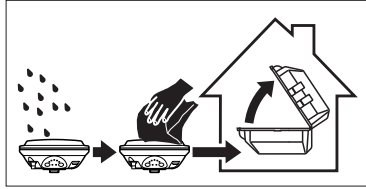

Cables and plugs

Keep plugs clean and dry. Blow away any dirt lodged in the plugs of the connecting cables.

Connectors with dust caps

Wet connectors must be dry before attaching the dust cap.

6 Technical Data

6.1 GS25 Technical Data

6.1.1 Tracking Characteristics

Satellite reception Multi-frequency

Instrument channels  Depending on the satellite systems and signals configured, a maximum number of 555 channels is allocated.

Supported signals

System	Signal
GPS	L1 C/A, L2P, L2C, L5
GLONASS	L1 C/A, L2P, L2C
Galileo	E1, E5a, E5b, AltBOC
BeiDou	B1, B2



Carrier phase and code measurements on L1, L2 and L5 (GPS) are fully independent with AS on or off.



Support of QZSS L1, L2S, L5Q, L6L and IRNSS L5A is incorporated and will be provided through future firmware upgrade.

6.1.2 Accuracy



Accuracy is dependent upon various factors including the number of satellites tracked, constellation geometry, observation time, ephemeris accuracy, ionospheric disturbance, multipath and resolved ambiguities.

The following accuracies, given as **root mean square**, are based on measurements processed using Infinity and on real-time measurements.

The use of multiple GNSS systems can increase accuracy by up to 30% relative to GPS only.

Differential code The baseline precision of a differential code solution for static and kinematic surveys is 25 cm.

Differential phase in post-processing

Type	Horizontal	Vertical
Static and rapid static	3 mm + 0.5 ppm	5 mm + 0.5 ppm
Kinematic	8 mm + 1 ppm	15 mm + 1 ppm
Static with long observations	3 mm + 0.1 ppm	3.5 mm + 0.4 ppm

Differential phase in real-time

Type	Horizontal	Vertical
Single Baseline (< 30 km)	8 mm + 1 ppm	15 mm + 1 ppm
Network RTK	8 mm + 0.5 ppm	15 mm + 0.5 ppm

6.1.3

Technical Data

Dimensions

The dimensions are given for the housing without the sockets.

Type	Length [m]	Width [m]	Thickness [m]
GS25	0.220	0.200	0.094

Weight

Instrument weights without battery and radio:

Type	Weight [kg]/[lbs]
GS25	1.84/4.06

Recording

Data (Leica GNSS raw data and RINEX data) can be recorded on the SD card. 1 GB is sufficient for over 1 year of raw data logging based on logging every 15 s from an average of 15 satellites.

Power

Power consumption: GS25, radio excluded: 3.7 W typically, 310 mA
External supply voltage: Nominal 12 V DC (---, GEV71 car battery cable to a 12 V car battery), voltage range 10.5 V-28 V DC

Internal Battery

GEB242
Type: Li-Ion
Voltage: 14.8 V
Capacity: 5.8 Ah

External battery

GEB371
Type: Li-Ion
Voltage: 13 V
Capacity: 16.8 Ah

Operating times

The given operating times are valid for

- GS25: instrument plus antenna; fully charged GEB242 battery.
- room temperature. Operating times will be shorter when working in cold weather.

Equipment			Operating time
Type	Radio	Digital cellular phone	
Static	-	-	26 h continuously
Rover	SATELLINE M3-TR4, receive (SLR6-1)	-	18 h continuously
Rover	-	Telit UC864-G (SLG1-2)	17 h continuously

Electrical data

Type	GS25
Voltage	-
Current	-
Frequency	
GPS, QZSS L1 1575.42 MHz	✓
GPS, QZSS L2 1227.60 MHz	✓
GPS, QZSS L5 1176.45 MHz	✓
GLONASS L1 1602.5625-1611.5 MHz	✓
GLONASS L2 1246.4375-1254.3 MHz	✓
Galileo E1 1575.42 MHz	✓
Galileo E5a 1176.45 MHz	✓
Galileo E5b 1207.14 MHz	✓
Galileo AltBOC 1191.795 MHz	✓
BeiDou B1 1561.098 MHz	✓
BeiDou B2 1207.14 MHz	✓
Gain (LNA [*])	Typically 27 dB
Noise Figure	Typically < 2 dB

* Dedicated by the connected active GNSS reference antenna, for example AS10



Galileo AltBOC covers bandwidth of Galileo E5a and E5b.

Environmental specifications

Temperature

Type	Operating temperature [°C]	Storage temperature [°C]
Instrument	-40 to +65	-40 to +80
Leica SD cards	-40 to +80	-40 to +80
Battery internal	-20 to +55	-40 to +70

Protection against water, dust and sand

Type	Protection
Instrument	IP68 (IEC 60529) Dust tight Protected against continuous immersion in water Tested for 2 h in 1.40 m depth

Humidity

Type	Protection
Instrument	Up to 100 % The effects of condensation are to be effectively counteracted by periodically drying out the instrument.

PPS output**PPS output characteristics:**

Accuracy: 120 ns (3 σ)
Output voltage: 5 V = High
Impedance: 50 Ω
Pulse length: 1 ms
Leading edge: Coinciding with the beginning of each epoch.
Positive/negative edge: Selectable

Cable connectivity:

Matched with an appropriate impedance of: 50 Ω
Socket: LEMO ERN.OS.250.CTL

Event input

Accuracy: 120 ns (1 σ)
Pulse type: TTL, positive or negative going pulse
Pulse length: 150 ns at minimum
Voltage: Typically 5 V (range 3-10 V)
Voltage level: Minimum 2.4 V = High
Maximum 0.6 V = Low
Pin definition: Centre = signal, Case = ground
Socket: LEMO HGP.00.250.CTL

Description and use The antenna is selected for use based upon the application. The table gives a description and the intended use of the individual antennas.

Type	Description	Use
AS05	GPS, GLONASS, SBAS single-frequency antenna with built-in ground plane.	With GS06 or GS10/GS25.
AS10	GPS, GLONASS, Galileo, BeiDou, SBAS, QZSS, L-band antenna with built-in ground plane.	With GS10/GS25.
AR10	GPS, GLONASS, Galileo, BeiDou, SBAS, QZSS, L-band antenna with large ground plane and built-in radome.	With GS10/GS25 where higher precision is required. For example static surveys of long baselines, tectonic plate monitoring and base stations.
AR20	GPS, GLONASS, Galileo, BeiDou, SBAS, QZSS, L-band antenna with gold choke ring ground plane. Optional protective radome.	High end applications, including all reference station and monitoring. Especially suited for Network RTK, where excellent multipath rejection and the best phase centre stability is required.
AR25	Dorne & Margolin GPS, GLONASS, Galileo, BeiDou, SBAS, QZSS, L-band antenna with 3D choke ring ground plane. Optional protective radome.	With GS10/GS25 where higher precision is required. For example static surveys of long baselines, tectonic plate monitoring and base stations.

Dimensions

Type	AS05/AS10	AR10	AR20	AR25
Height	6.2 cm	14.0 cm	16.3 cm	20.0 cm
Diameter	17.0 cm	24.0 cm	32.0 cm	38.0 cm

Connector

AS05/AS10/AR10:	TNC female
AR20/AR25:	N female

Mounting

All antennas:	5/8" Whitworth
---------------	----------------

Weight

AS05/AS10:	0.4 kg
AR10:	1.1 kg
AR20:	5.9 kg
AR25:	7.6 kg, radome 1.1 kg

Electrical data

Type	AS05	AS10	AR10	AR20	AR25
Voltage	4.5 V to 18 V DC	4.5 V to 18 V DC	3.3 V to 12 V DC	3.3 V to 12 V DC	3.3 V to 12 V DC
Current	35 mA typ.	35 mA typ.	100 mA max	100 mA max	100 mA max
Frequency					
GPS L1 1575.42 MHz	✓	✓	✓	✓	✓
GPS L2 1227.60 MHz	-	✓	✓	✓	✓
GPS L5 1176.45 MHz	-	✓	✓	✓	✓
GLONASS L1 1602.5625- 1611.5 MHz	✓	✓	✓	✓	✓
GLONASS L2 1246.4375- 1254.3 MHz	-	✓	✓	✓	✓
GLONASS L3	-	-	✓	✓	✓
GLONASS L5	-	-	-	✓	-
Galileo E1 1575.42 MHz	-	✓	✓	✓	✓
Galileo E5a 1176.45 MHz	-	✓	✓	✓	✓
Galileo E5b 1207.14 MHz	-	✓	✓	✓	✓
Galileo AltBOC 1191.795 MHz	-	✓	✓	✓	✓
Galileo E6 1278.75 MHz	-	-	✓	✓	✓
BeiDou B1 1561.098 MHz	✓	✓	✓	✓	✓
BeiDou B2 1207.14 MHz	-	✓	✓	✓	✓
BeiDou B3 1268.52 MHz	-	-	✓	✓	✓
Gain (typically)	27 dBi	29 dBi	29 dBi	29 dBi	40 dBi
Noise Figure (typically)	< 2 dBi	< 2 dBi	< 2 dBi	< 2 dBi	< 1.2 dBi max



Galileo AltBOC covers bandwidth of Galileo E5a and E5b.

Environmental specifications**Temperature**

Type	Operating temperature [°C]	Storage temperature [°C]
AS05/AS10/AR10	-40 to +70	-55 to +85
AR20/AR25	-55 to +85	-55 to +90

Protection against water, dust and sand

Type	Protection
AS05/AS10	IP68 (IEC 60529) Dust tight Protected against water jets Protected against continuous immersion in water Tested for 2 h in 1.40 m depth
AR10/AR20/AR25	IP67 (IEC 60529) Dust tight Protected against water jets Waterproof to 1 m temporary immersion

Humidity

Type	Protection
All antennas	Up to 100 % The effects of condensation are to be effectively counteracted by periodically drying out the antenna.

Cable length

Separation distance from instrument ...	to antenna	Supplied cable lengths [m]	Optional cable lengths [m]
GS10/GS25	AS05/AS10/ AR10/AR20/AR25	1.2 2.8 10	30 50 70

6.3

Conformity to National Regulations

Conformity to National Regulations

For products which do not fall under R&TTE directive:



Hereby, Leica Geosystems AG, declares that the product/s is/are in compliance with the essential requirements and other relevant provisions of the applicable European Directives. The declaration of conformity can be consulted at <http://www.leica-geosystems.com/ce>.

- Japanese Radio Law and Japanese Telecommunications Business Law Compliance.
 - This device is granted pursuant to the Japanese Radio Law and the Japanese Telecommunications Business Law.
 - This device should not be modified (otherwise the granted designation number will become invalid).

6.3.1

GS25

Conformity to national regulations

- FCC Part 15 (applicable in US)
- Hereby, Leica Geosystems AG, declares that the product GS25 is in compliance with the essential requirements and other relevant provisions of Directive 1999/5/EC. The declaration of conformity can be consulted at <http://www.leica-geosystems.com/ce>.



Class 1 equipment according European Directive 1999/5/EC (R&TTE) can be placed on the market and be put into service without restrictions in any EEA member state.

- The conformity for countries with other national regulations not covered by the FCC part 15 or European directive 1999/5/EC has to be approved prior to use and operation.
- Japanese Radio Law and Japanese Telecommunications Business Law Compliance.
 - This device is granted pursuant to the Japanese Radio Law and the Japanese Telecommunications Business Law.
 - This device should not be modified (otherwise the granted designation number will become invalid).

Frequency band

Type	Frequency band [MHz]
GS25	1176.45 1191.795 1207.14 1227.60 1246.4375 - 1254.3 1575.42 1602.4375 - 1611.5
Bluetooth	2402 - 2480

Output power

Type	Output power [mW]
GNSS	Receive only
Bluetooth	5 (Class 1)

Antenna

Type	Antenna	Gain [dBi]	Connector	Frequency band [MHz]
GNSS	External GNSS antenna element (receive only)	-	-	-
Bluetooth	Internal Microstrip antenna	1.5	-	-

Conformity to national regulations

- FCC Part 15, 90 (applicable in US)
- Hereby, Leica Geosystems AG, declares that the product SLR5-1 is in compliance with the essential requirements and other relevant provisions of Directive 1999/5/EC. The declaration of conformity can be consulted at <http://www.leica-geosystems.com/ce>.



Class 2 equipment according European Directive 1999/5/EC (R&TTE).

- The conformity for countries with other national regulations not covered by the FCC part 15, 90 or European directive 1999/5/EC has to be approved prior to use and operation.
- Japanese Radio Law and Japanese Telecommunications Business Law Compliance.
 - This device is granted pursuant to the Japanese Radio Law and the Japanese Telecommunications Business Law.
 - This device should not be modified (otherwise the granted designation number will become invalid).

Frequency band

403 MHz - 470 MHz

Output power

SLR5-1: 0.5 W-1.0 W

Antenna

Type	GAT1	GAT2
Frequency band [MHz]	400 - 435	435 - 470
Type	Detachable $\lambda/2$ antenna	Detachable $\lambda/2$ antenna
Connector	TNC	TNC

Specific Absorption Rate (SAR)

The product meets the limits for the maximum permissible exposure of the guide-lines and standards which are force in this respect. The product must be used with the recommended antenna. A separation distance of at least 20 centimetres should be kept between the antenna and the body of the user or nearby person within the intended application.

Conformity to national regulations

- FCC Part 15, 90 (applicable in US)
- Hereby, Leica Geosystems AG, declares that the product SLR6-1 is in compliance with the essential requirements and other relevant provisions of Directive 1999/5/EC and other applicable European Directives. The declaration of conformity can be consulted at <http://www.leica-geosystems.com/ce>.



Class 2 equipment according European Directive 1999/5/EC (R&TTE)

- The conformity for countries with other national regulations not covered by the FCC part 15, 90 or European directive 1999/5/EC has to be approved prior to use and operation.
- Japanese Radio Law and Japanese Telecommunications Business Law Compliance.
 - This device is granted pursuant to the Japanese Radio Law (電波法) and the Japanese Telecommunications Business Law (電気通信事業法).
 - This device should not be modified (otherwise the granted designation number will become invalid).

Frequency band

403 MHz - 470 MHz

Output power

SLR6-1: 0.5 W-1.0 W

Antenna

Type	Internal	GAT1	GAT2
Frequency band [MHz]	400 - 470	400 - 435	435 - 470
Type	Internal	Detachable $\lambda/2$ antenna	Detachable $\lambda/2$ antenna
Connector	-	TNC	TNC

Specific Absorption Rate (SAR)

The product meets the limits for the maximum permissible exposure of the guide-lines and standards which are force in this respect. The product must be used with the recommended antenna. A separation distance of at least 20 centimetres should be kept between the antenna and the body of the user or nearby person within the intended application.

Conformity to national regulations

- FCC Part 15, 22 and 24 (applicable in US)
- Hereby, Leica Geosystems AG, declares that the SLG1-2 is in compliance with the essential requirements and other relevant provisions of Directive 1999/5/EC. The declaration of conformity may be consulted at <http://www.leica-geosystems.com/ce>.



Class 1 equipment according European Directive 1999/5/EC (R&TTE) can be placed on the market and be put into service without restrictions in any EEA Member state.

- The conformity for countries with other national regulations not covered by the FCC part 15, 22 and 24 or European directive 1999/5/EC has to be approved prior to use and operation.
- Japanese Radio Law and Japanese Telecommunications Business Law Compliance.
 - This device is granted pursuant to the Japanese Radio Law and the Japanese Telecommunications Business Law.
 - This device should not be modified (otherwise the granted designation number will become invalid).

Frequency band

UMTS/HSDPA (WCDMA/FDD) 850 MHz/ 1900 MHz/ 2100 MHz
 Quad-Band EGSM 850 MHz/ 900 MHz/ 1800 MHz/ 1900 MHz
 GPRS multi-slot class 12
 EDGE multi-slot class 12

Output power

EGSM850/900: 2 W
 GSM1800/1900: 1 W
 UMTS2100: 0.25 W
 EDGE850/900: 0.5 W
 EDGE1800/1900: 0.4 W

Antenna

Type	GAT3	GAT5	GAT18
Frequency band [MHz]	890 - 960 / 1710 - 1880 / 1920 - 2170	824 - 894 / 1850 - 1990	824 - 894 / 890 - 960 / 1710 - 1880 / 1850 - 1990 / 1920 - 2170
Type	Detachable $\lambda/2$ antenna	Detachable $\lambda/2$ antenna	Detachable $\lambda/2$ antenna
Connector	TNC	TNC	TNC



Specific Absorption Rate (SAR)

The product meets the limits for the maximum permissible exposure of the guide-lines and standards which are force in this respect. The product must be used with the recommended antenna. A separation distance of at least 20 centimetres should be kept between the antenna and the body of the user or nearby person within the intended application.

Dangerous Goods Regulations

The products of Leica Geosystems are powered by Lithium batteries.

Lithium batteries can be dangerous under certain conditions and can pose a safety hazard. In certain conditions, Lithium batteries can overheat and ignite.

-  When carrying or shipping your Leica product with Lithium batteries onboard a commercial aircraft, you must do so in accordance with the **IATA Dangerous Goods Regulations**.
 -  Leica Geosystems has developed **Guidelines** on “How to carry Leica products” and “How to ship Leica products” with Lithium batteries. Before any transportation of a Leica product, we ask you to consult these guidelines on our web page (<http://www.leica-geosystems.com/dgr>) to ensure that you are in accordance with the IATA Dangerous Goods Regulations and that the Leica products can be transported correctly.
 -  Damaged or defective batteries are prohibited from being carried or transported onboard any aircraft. Therefore, ensure that the condition of any battery is safe for transportation.
-

Software Licence Agreement

This product contains software that is preinstalled on the product, or that is supplied to you on a data carrier medium, or that can be downloaded by you online according to prior authorisation from Leica Geosystems. Such software is protected by copyright and other laws and its use is defined and regulated by the Leica Geosystems Software Licence Agreement, which covers aspects such as, but not limited to, Scope of the Licence, Warranty, Intellectual Property Rights, Limitation of Liability, Exclusion of other Assurances, Governing Law and Place of Jurisdiction. Please make sure, that at any time you fully comply with the terms and conditions of the Leica Geosystems Software Licence Agreement.

Such agreement is provided together with all products and can also be referred to and downloaded at the Leica Geosystems home page at <http://leica-geosystems.com/about-us/compliance-standards/legal-documents> or collected from your Leica Geosystems distributor.

You must not install or use the software unless you have read and accepted the terms and conditions of the Leica Geosystems Software Licence Agreement. Installation or use of the software or any part thereof, is deemed to be an acceptance of all the terms and conditions of such Licence Agreement. If you do not agree to all or some of the terms of such Licence Agreement, you must not download, install or use the software and you must return the unused software together with its accompanying documentation and the purchase receipt to the distributor from whom you purchased the product within ten (10) days of purchase to obtain a full refund of the purchase price.

Appendix A Pin Assignments and Sockets

Description

Some applications require knowledge of the pin assignments for the GS25 ports. In this chapter, the pin assignments and sockets for the ports of the GS25 are explained.

Ports at the instrument back panel

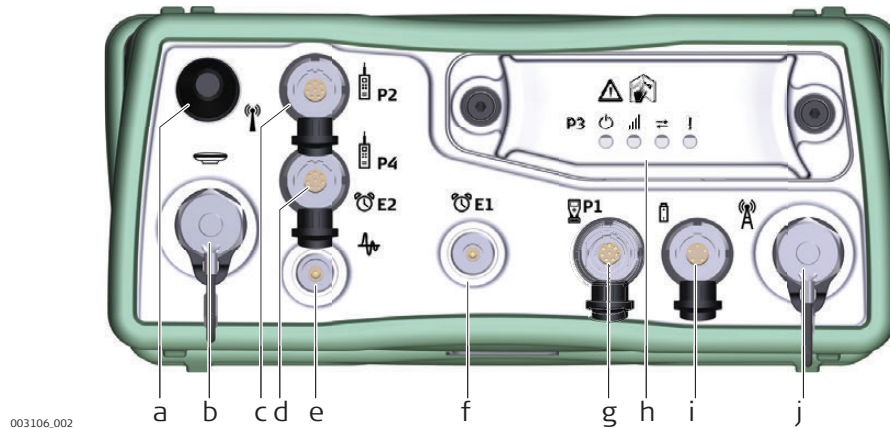

- a) Port BT: Bluetooth antenna
- b) Port ANT: GNSS antenna in
- c) Port P2: Power out, data in/out or remote interface in/out. 8 pin LEMO
- d) Port P4 and E2: Serial/Event port. 8 pin LEMO
- e) Port PPS: Puls per second output
- f) Port E1: Event 1
- g) Port P1: CS field controller in/out or remote interface in/out. 8 pin LEMO
- h) Port 3: Communication slot-in port and LEDs
- i) Port PWR: Power in. 5 pin LEMO
- j) Communication Slot-in port, Antenna, TNC

Pin assignments for port P1



Pin	Signal Name	Function	Direction
1	USB_D+	USB data line	In or out
2	USB_D-	USB data line	In or out
3	GND	Signal ground	-
4	RxD	RS232, receive data	In
5	TxD	RS232, transmit data	Out
6	ID	Identification pin	In or out
7	PWR	Power input, 10.5 V-28 V	In
8	TRM_ON/USB_ID	RS232, general-purpose signal	In or out

Pin assignments for port P2

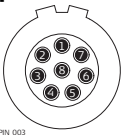

Pin	Signal Name	Function	Direction
1	RTS	RS232, ready to send	Out
2	CTS	RS232, clear to send	In
3	GND	Signal ground	-
4	RxD	RS232, receive data	In
5	TxD	RS232, transmit data	Out
6	ID	Identification pin	In
7	GPIO	RS232, configurable function	In or out
8	+12 V	12 V power supply out	Out

Pin assignments for port P3

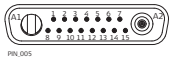

Pin	Signal Name	Function	Direction
1	PWR	4 V power supply in	In
2	Tx	Transmit data	In
3	Rx	Receive data	Out
4	GPO/DCD	General-purpose out, carrier detect out	Out
5	RTS	Request to send	In
6	CTS	Clear to send	Out
7	GPI/CFG	General-purpose in, config mode in	In
8	PWR	6 V power supply in	In
9	GPIO	General-purpose signal	In or out
10	GND	Signal and chassis ground	-
11	USB+	USB data line (+)	In or out
12	USB-	USB data line (-)	In or out
13	GND	Signal and chassis ground	-
14	ID	Identification pin	In or out
15	GPIO	General-purpose signal	In or out
A1	NC	Not used	-
A2	RF1	Antenna port, radio to antenna	-

Pin assignments for port P4/E2

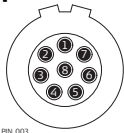

Pin	Signal Name	Function	Direction
1	RTS	RS232, ready to send	Out
2	CTS	RS232, clear to send	In
3	GND	Signal ground	-
4	RxD	RS232, receive data	In
5	TxD	RS232, transmit data	Out
6	ID	Identification pin	In or out
7	GPIO/EVT2 IN	RS232, general purpose input/output	In or out
8	+12 V	12 V power supply out	Out

Pin assignments for port PWR

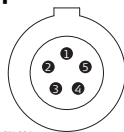

Pin	Signal Name	Function	Direction
1	PWR1	Power input, 11 V-28 V	In
2	ID1	Identification pin	In
3	GND	Signal ground	-
4	PWR2	Power input, 11 V-28 V	In
5	ID2	Identification pin	In

793206-3.0.0en

Original text

Printed in Switzerland

© 2016 Leica Geosystems AG, Heerbrugg, Switzerland

Leica Geosystems AG

Heinrich-Wild-Strasse

CH-9435 Heerbrugg

Switzerland

Phone +41 71 727 31 31

www.leica-geosystems.com

- when it has to be **right**

Leica
Geosystems