

**Agilent 33500 Series
30 MHz Function /
Arbitrary Waveform
Generator**

User's Guide



Agilent Technologies

Notices

© Agilent Technologies, Inc. 2010

No part of this manual may be reproduced in any form or by any means (including electronic storage and retrieval or translation into a foreign language) without prior agreement and written consent from Agilent Technologies, Inc. as governed by United States and international copyright laws.

Manual Part Number

33520-90001

First Edition, June 2010

Second Edition, September 2010

Printed in Malaysia

Agilent Technologies, Inc.
900 S. Taft Ave.
Loveland, CO 80537 USA

Adobe, the Adobe Logo, Acrobat and the Acrobat Logo are trademarks of Adobe Systems Incorporated.

Microsoft is either a registered trademark or a trademark of Microsoft Corporation in the United States and/or other countries.

Windows and MS Windows are U.S. registered trademarks of Microsoft Corporation.

Software Updates/Licenses

Periodically, Agilent releases software updates to fix known defects and incorporate product enhancements. To search for software updates and the latest documentation for your product, go to the product page at:

www.agilent.com/find/33521A

www.agilent.com/find/33522A

A portion of the software in this product is licensed under terms of the General Public License Version 2 ("GPLv2"). The text of the license and source code can be found at:

www.agilent.com/find/GPLV2

This product utilizes Microsoft Windows CE. Agilent highly recommends that all Windows-based computers connected to Windows CE instruments utilize current anti-virus software. For more information, go to the product page at:

www.agilent.com/find/33521A

www.agilent.com/find/33522A

Declaration of Conformity

Declarations of Conformity for this product and for other Agilent products may be downloaded from the Web. Go to <http://regulations.corporate.agilent.com> and click on "Declarations of Conformity." You can then search by product number to find the latest Declaration of Conformity.

Warranty

The material contained in this document is provided "as is," and is subject to being changed, without notice, in future editions. Further, to the maximum extent permitted by applicable law, Agilent disclaims all warranties, either express or implied, with regard to this manual and any information contained herein, including but not limited to the implied warranties of merchantability and fitness for a particular purpose. Agilent shall not be liable for errors or for incidental or consequential damages in connection with the furnishing, use, or performance of this document or of any information contained herein. Should Agilent and the user have a separate written agreement with warranty terms covering the material in this document that conflict with these terms, the warranty terms in the separate agreement shall control.

Technology Licenses

The hardware and/or software described in this document are furnished under a license and may be used or copied only in accordance with the terms of such license.

Restricted Rights Legend

If software is for use in the performance of a U.S. Government prime contract or subcontract, Software is delivered and licensed as "Commercial computer software" as defined in DFAR 252.227-7014 (June 1995), or as a "commercial item" as defined in FAR 2.101(a) or as "Restricted computer software" as defined in FAR 52.227-19 (June 1987) or any equivalent agency regulation or contract clause. Use, duplication or disclosure of Software is subject to Agilent Technologies' standard commercial license terms, and non-DOD Departments and Agencies of the U.S. Government will receive no greater than Restricted Rights as defined in FAR 52.227-19(c)(1-2) (June 1987). U.S. Government users will receive no greater than Limited Rights as defined in FAR 52.227-14 (June 1987) or DFAR 252.227-7015 (b)(2) (November 1995), as applicable in any technical data.

Safety Notices

CAUTION

A **CAUTION** notice denotes a hazard. It calls attention to an operating procedure, practice, or the like that, if not correctly performed or adhered to, could result in damage to the product or loss of important data. Do not proceed beyond a **CAUTION** notice until the indicated conditions are fully understood and met.

WARNING

A **WARNING** notice denotes a hazard. It calls attention to an operating procedure, practice, or the like that, if not correctly performed or adhered to, could result in personal injury or death. Do not proceed beyond a **WARNING** notice until the indicated conditions are fully understood and met.

Additional Safety Notices

The following general safety precautions must be observed during all phases of operation of this instrument. Failure to comply with these precautions or with specific warnings or instructions elsewhere in this manual violates safety standards of design, manufacture, and intended use of the instrument. Agilent Technologies assumes no liability of the customer's failure to comply with the requirements.

General

Do not use this product in any manner not specified by the manufacturer. The protective features of this product may be impaired if it is used in a manner not specified in the operation instructions.

Before Applying Power

Verify that all safety precautions are taken. Make all connections to the unit before applying power and select the appropriate power line voltage on the fuse module.

Ground the Instrument

This product is provided with protective earth terminals. To minimize shock hazard, the instrument must be connected to the ac power mains through a

grounded power cable, with the ground wire firmly connected to an electrical ground (safety ground) at the power outlet. Any interruption of the protective (grounding) conductor or disconnection of the protective earth terminal will cause a potential shock hazard that could result in personal injury.

Do Not Operate in an Explosive Atmosphere

Do not operate the instrument in the presence of flammable gases or fumes.

Do Not Remove the Instrument Cover

Only qualified, service-trained personal who are aware of the hazards involved should remove instrument covers. Always disconnect the power cable and any external circuits before removing the instrument cover.

Do Not Modify the Instrument

Do not install substitute parts or perform any unauthorized modification to the product. Return the product to an Agilent Sales and Service Office for service and repair to ensure that safety features are maintained.

In Case of Damage

Instruments that appear damaged or defective should be made inoperative and secured against unintended operation until they can be repaired by qualified service personnel.

CAUTION

Unless otherwise noted in the specifications, this instrument or system is intended for indoor use in an installation category II, pollution degree 2 environment per IEC 61010-1 and 664 respectively. It is designed to operate at a maximum relative humidity of 20% to 80% at 40 °C or less (non-condensing). This instrument or system is designed to operate at altitudes up to 2000 meters, and at temperatures between 0 °C and 55 °C.

Technical Support

If you have questions about your shipment, or if you need information about warranty, service, or technical support, contact Agilent Technologies:

In the United States: (800) 829-4444

In Europe: 31 20 547 2111

In Japan: 0120-421-345

Or go to

www.agilent.com/find/assist

for information on contacting Agilent in your country of specific location. You can also contact your Agilent Technologies Representative.

Safety Symbols



Alternating current



Frame or chassis terminal



Standby supply. Unit is not completely disconnected from AC mains when switch is off.



Caution, risk of electric shock



Caution, refer to accompanying documents



Earth ground terminal



The CE mark is a registered trademark of the European Community.



The CSA mark is a registered trademark of the CSA-International.



N10149

The C-tick mark is a registered trademark of the Spectrum Management Agency of Australia. This signifies compliance with the Australian EMC Framework regulations under the terms of the Radio Communications Act of 1992.



Contains one or more of the 6 hazardous substances above the maximum concentration value (MCV), 40 Year EPUP.

ISM1-A

This text indicates that the instrument is an Industrial Scientific and Medical Group 1 Class A product (CISPER 11, Clause 4).

ICES/
NMB
-001

This text indicates product compliance with the Canadian Interference-Causing Equipment Standard (ICES-001).

User's Guide

Publication Number 33520-90001 (*order as 33520-90000 manual set*)
Edition 2, September 2010

Copyright © 2010 Agilent Technologies, Inc.

Agilent 33500 Series
30 MHz Function /
Arbitrary Waveform Generator

Agilent 33500 Series at a Glance

The Agilent Technologies 33500 Series is a 30 MHz synthesized waveform generator with built-in arbitrary waveform and pulse capabilities. Its combination of bench-top and system features makes this waveform generator a versatile solution for your testing requirements now and in the future.

Convenient bench-top features

- 16 standard waveforms
- Built-in 16-bit 250 MSa/s arbitrary waveform capability
- Precise pulse waveform capabilities with adjustable edge time
- LCD display provides numeric and graphical views
- Easy-to-use knob and numeric keypad
- Instrument state storage with user-defined names
- Portable, ruggedized case with non-skid feet

Flexible system features

- Downloadable 1M-point or optional 16M-point arbitrary waveform memories. For details, see:

www.agilent.com/find/33521U

www.agilent.com/find/33522U

- Optional GPIB (IEEE-488)
- Standard USB and LAN remote interfaces
- LXI Class C Compliant
- SCPI (Standard Commands for Programmable Instruments) compatibility

Note: *Unless otherwise indicated, this manual applies to all Serial Numbers.*

The Front Panel at a Glance

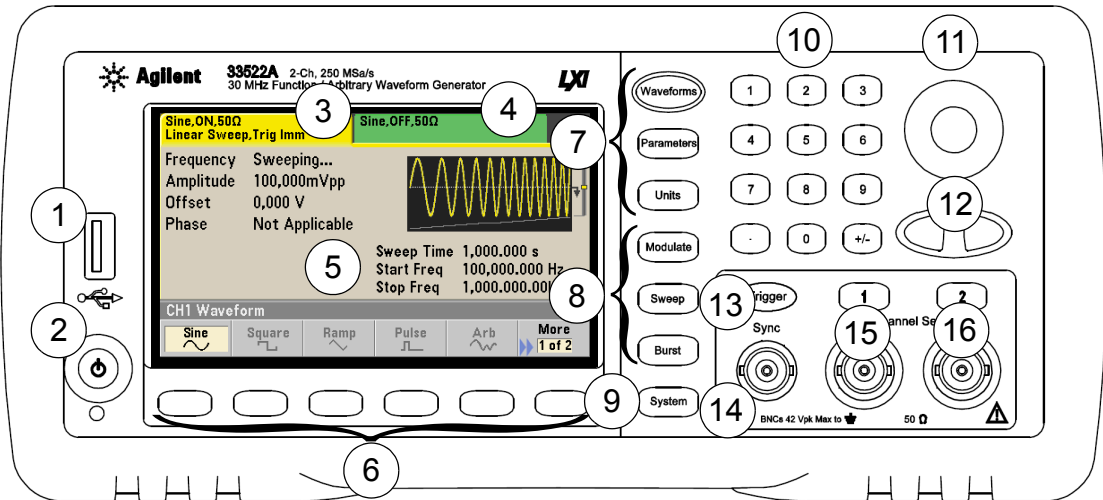

- | | |
|---------------------------------------|--|
| 1 USB Port | 9 System Key |
| 2 On/Off Switch | 10 Numeric Keypad |
| 3 Channel 1 Summary Tab | 11 Knob |
| 4 Channel 2 Summary Tab | 12 Cursor Keys (Arrows) |
| 5 Waveform and Parameter Display Area | 13 Manual Trigger (Sweep and Burst only) |
| 6 Menu Operation Softkeys | 14 Sync Connector |
| 7 Waveforms/Parameters/Units Keys | 15 Channel 1 |
| 8 Modulate/Sweep/Burst Keys | 16 Channel 2 (2-channel instrument only) |

Note: To get context-sensitive help on any front-panel key or menu softkey, press and hold down that key.

The Front-Panel Display at a Glance

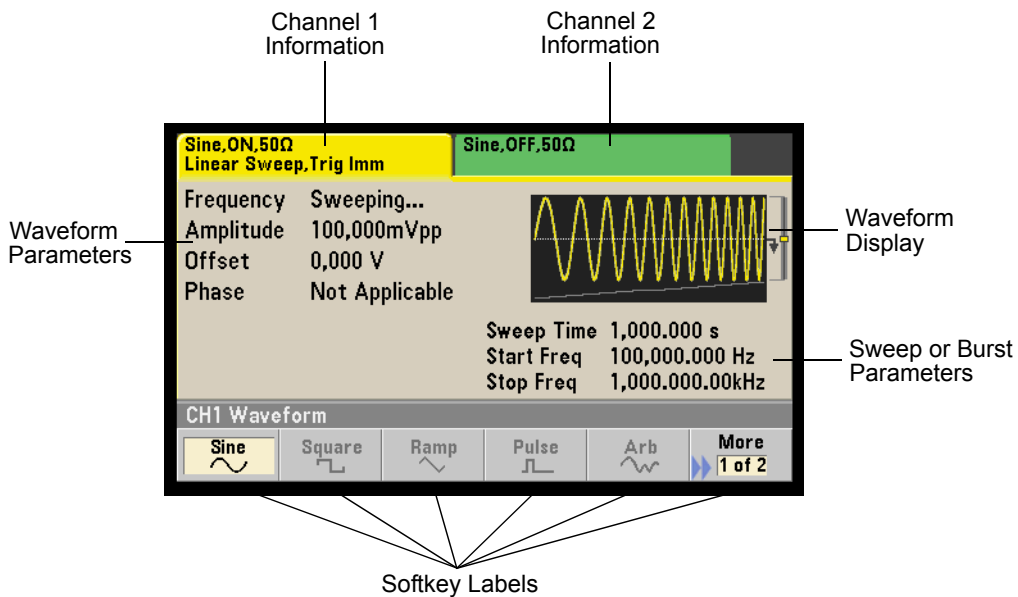

Front-Panel Number Entry

You can enter numbers from the front-panel using one of two methods.

Use the knob and cursor keys to modify the displayed number.

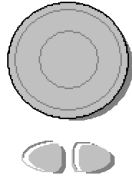

1. Use the keys below the knob to move the cursor left or right.
2. Rotate the knob to change a digit (clockwise to increase).

Use the keypad to enter numbers and the softkeys to select units.



1. Key in a value using the keypad.
2. Select a unit to enter the value.
3. Use the +/- key to change the sign of the number.
4. The left arrow backspaces and clears the last digit.

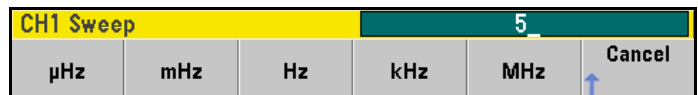

The Rear Panel at a Glance

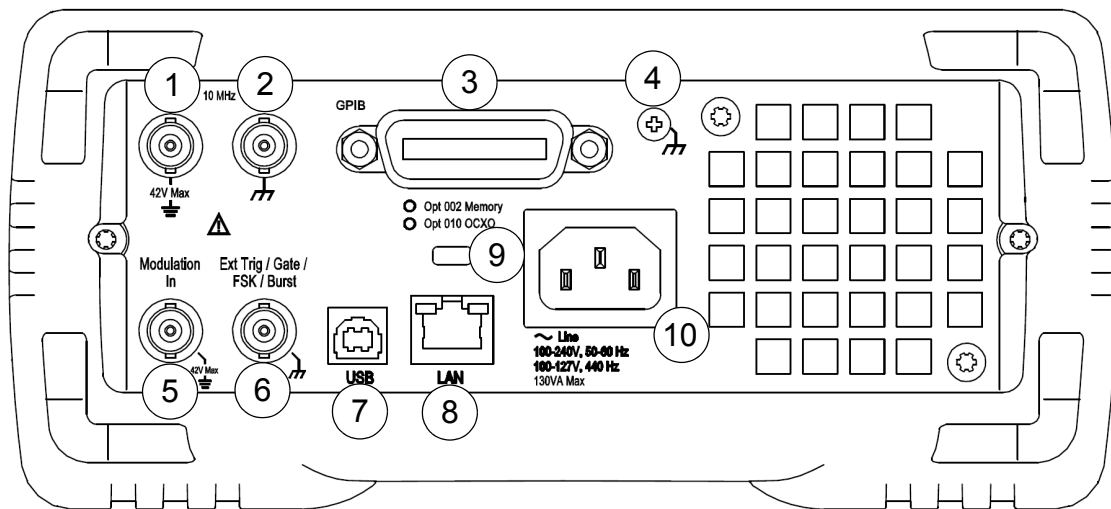

- 1 External 10 MHz Reference Input Terminal
- 2 Internal 10 MHz Reference Output Terminal
- 3 GPIB Interface Connector (option 400)
- 4 Chassis Ground
- 5 External Modulation Input Terminal
- 6 Input: External Trig/Gate/FSK/Burst
- 7 USB Interface Connector
- 8 Local Area Network (LAN) Connector
- 9 Instrument Cable Lock
- 10 AC Power

WARNING

For protection from electrical shock, the power cord ground must not be defeated. If only a two-contact electrical outlet is available, connect the instrument's chassis ground screw (see above) to a good earth ground.

In This Book

Quick Start Chapter 1 prepares the waveform generator for use and helps you get familiar with a few of its front-panel features.

Front-Panel Menu Operation Chapter 2 introduces you to the front-panel menu and describes some of the waveform generator's menu features.

Features and Functions Chapter 3 gives a detailed description of the waveform generator's capabilities and operation. You will find this chapter useful whether you are operating the waveform generator from the front panel or over the remote interface.

Application Programs Chapter 4 contains several remote interface application programs to help you develop programs for your application.

Tutorial Chapter 5 discusses the fundamentals of signal generation and modulation techniques.

Specifications Chapter 6 lists the waveform generator's specifications.



You can contact Agilent Technologies at one of the following telephone numbers for warranty, service, or technical support information.

In the United States: (800) 829-4444

In Europe: 31 20 547 2111

In Japan: 0120-421-345

Or use our Web link for information on contacting Agilent worldwide.

www.agilent.com/find/assist

Or contact your Agilent Technologies Representative.

Contents

Chapter 1 Quick Start 15

- To Prepare the Waveform Generator for Use 17
- To Adjust the Carrying Handle 19
- To Set the Output Frequency 20
- To Set the Output Amplitude 22
- To Set a DC Offset Voltage 25
- To Set the High-Level and Low-Level Values 27
- To Output a DC Voltage 20
- To Set the Duty Cycle of a Square Wave 30
- To Configure a Pulse Waveform 32
- To Select a Stored Arbitrary Waveform 34
- To Use the Built-In Help System 33
- To Rack Mount the Waveform Generator 38

Chapter 2 Front-Panel Menu Operation 41

- Front-Panel Menu Reference 43
- To Select the Output Termination 47
- To Reset the Waveform Generator 48
- To Output a Modulated Waveform 49
- To Output an FSK Waveform 51
- To Output a PWM Waveform 53
- To Output a Frequency Sweep 56
- To Output a Burst Waveform 59
- To Trigger a Sweep or Burst 62
- To Store the Instrument State 63
- To Configure the Remote Interface 65
- To Set up an Arbitrary Waveform 73

Contents

Chapter 3 Features and Functions 89

Output Configuration	92
Pulse Waveforms	110
Amplitude Modulation (AM)	114
Frequency Modulation (FM)	119
Phase Modulation (PM)	125
Frequency-Shift Keying (FSK) Modulation	130
Pulse Width Modulation (PWM)	134
Sum Modulation (Sum)	139
Frequency Sweep	143
Burst Mode	152
Triggering	161
System-Related Operations	167
Remote Interface Configuration	178
External Timebase Reference	187
Calibration Overview	190
Embedded Waveform Editor	194
Factory Default Settings	215

Chapter 4 Application Programs 217

Introduction	218
Program Listings	220

Chapter 5 Tutorial 243

Chapter 6 Specifications 261

Index 269

Quick Start

Quick Start

One of the first things you will want to do with your waveform generator is to become acquainted with the front panel. We have written the exercises in this chapter to prepare the instrument for use and help you get familiar with some of its front-panel operations. This chapter is divided into the following sections:

- To Prepare the Waveform Generator for Use, *on page 17*
- To Adjust the Carrying Handle, *on page 19*
- To Set the Output Frequency, *on page 20*
- To Set the Output Amplitude, *on page 22*
- To Set a DC Offset Voltage, *on page 25*
- To Set the High-Level and Low-Level Values, *on page 27*
- To Output a DC Voltage, *on page 29*
- To Set the Duty Cycle of a Square Wave, *on page 30*
- To Configure a Pulse Waveform, *on page 32*
- To Select a Stored Arbitrary Waveform, *on page 34*
- To Use the Built-In Help System, *on page 35*
- To Rack Mount the Waveform Generator, *on page 38*

To Prepare the Waveform Generator for Use

1 Check the list of supplied items.

Verify that you have received the following items with your instrument. If anything is missing, please contact your nearest Agilent Sales Office.

- Power cord (for country of destination).
- Certificate of Calibration.
- *Agilent 33500 Series Product Reference CD* (product software, programming examples, and manuals).
- *Agilent Automation-Ready CD* (Agilent IO Libraries Suite).
- USB 2.0 cable.

Note: All of the 33500 Series product documentation is provided on the *Agilent 33500 Series Product Reference CD* that comes with the product, and is also available on the Web at www.agilent.com/find/33521A and www.agilent.com/find/33522A. Printed (hardcopy) manuals are available as an extra cost option.



2 Connect the power cord and turn on the waveform generator.

The instrument runs a power-on self test. When the instrument is ready for use it displays a message about how to obtain help, along with the current IP address. The instrument also displays the GPIB address if the GPIB option is installed and GPIB is enabled. The waveform generator powers up in the *sine wave* function at 1 kHz with an amplitude of 100 mV peak-to-peak (into a 50 Ω termination). At power-on, the channel output connectors are disabled. To enable output on a channel connector, press the **Channel** (33521A) **1** or **2** (33522A) button and then press the **Output Off / On** softkey.

If the waveform generator *does not* turn on, verify that the power cord is firmly connected to the power receptacle on the rear panel (the power-line voltage is automatically sensed at power-on). You should also make sure that the waveform generator is connected to an energized power source. Then, verify that the waveform generator is turned on.

Also look at the LED below the power switch. If it is off, there is no AC power connected. If it is amber, the instrument is in standby mode with AC power connected, and if it is green, the instrument is on.

To Prepare the Waveform Generator for Use

To turn off the instrument, you must hold the power switch down for about 500 ms. This prevents you from accidentally turning off the instrument by brushing against the power switch.

If the power-on self test fails, the instrument shows the ERR annunciator in the upper right corner of the display. It also prominently displays the following message:

```
Check for error messages in the error queue.
```

See the *Agilent 33500 Series Service Guide* for information on error codes, and for instructions on returning the waveform generator to Agilent for service.

To Adjust the Carrying Handle

To adjust the position, grasp the handle by the sides and *pull outward*. Then, rotate the handle to the desired position.

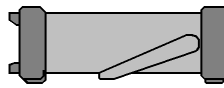

Retracted

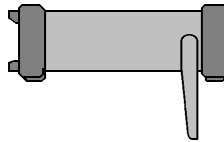

Extended

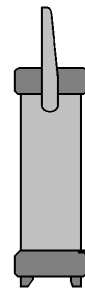

**Carrying
Position**

To Set the Output Frequency

At power-on, the waveform is configured for a sine wave at 1 kHz with an amplitude of 100 mV peak-to-peak (into a 50Ω termination).

The following steps show you how to change the frequency to 1.2 MHz.

- 1 Press the **Parameters** button, followed by the **Frequency** softkey.

The displayed frequency is either the power-on value or the frequency previously selected. When you change functions, the same frequency is used if the present value is valid for the new function. To set the waveform *period* instead, press **Units**, then press the **Frequency** softkey to toggle to the **Period** softkey (the current **Frequency** selection is highlighted in the image below.).



- 2 Enter the magnitude of the desired frequency.

Using the numeric keypad, enter the value 1.2.

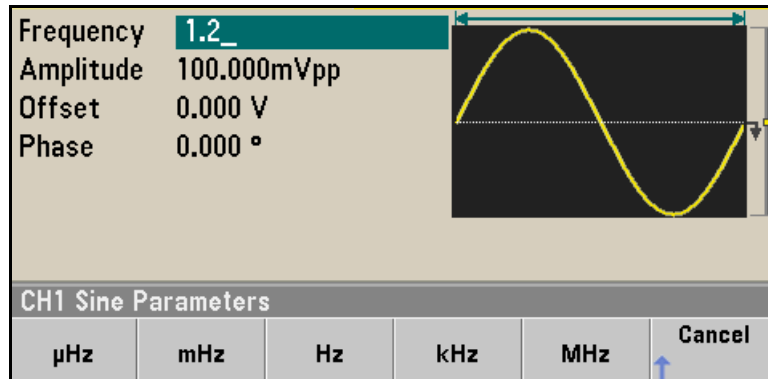

3 Select the desired units.

Press the softkey that corresponds to the desired units. When you select the units, the waveform generator outputs a waveform with the displayed frequency (if the output is enabled). For this example, press **MHz**.

A screenshot of a device's display showing the word "Frequency" in a light-colored font on the left, and the value "1.200,000,000MHz" in a dark green font on the right. The entire display area is enclosed in a thin black border.

Note: *You can also enter the desired value using the knob and cursor keys.*

To Set the Output Amplitude

At power-on, the waveform generator is configured for a sine wave with an amplitude of 100 mV peak-to-peak (into a 50Ω termination).

The following steps show you how to change the amplitude to 50 mVpp.

- 1 Press **Units**, then the softkey marked **Amp/Offs** or **High/Low** to make sure that you are in **Amp/Offs**.

The displayed amplitude is either the power-on value or the amplitude previously selected. When you change functions, the same amplitude is used if the present value is valid for the new function. To choose whether you want to specify voltage as amplitude and offset or high and low values, press **Units** and then the second softkey. In this case, we will highlight **Amp/Offs**.

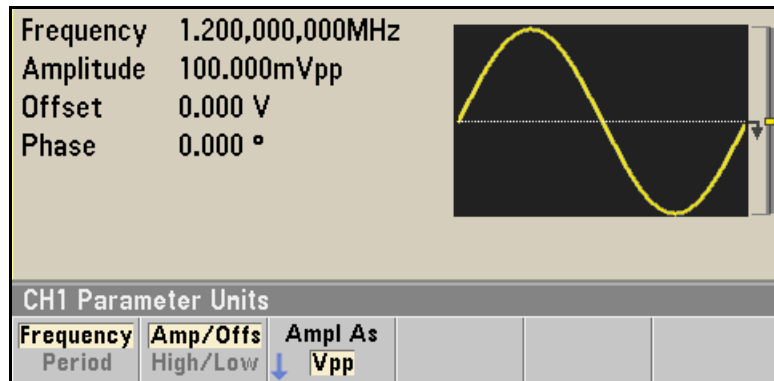

2 Enter the magnitude of the desired amplitude.

Press **Parameters** and then press **Amplitude**. Using the numeric keypad, enter the number 50.

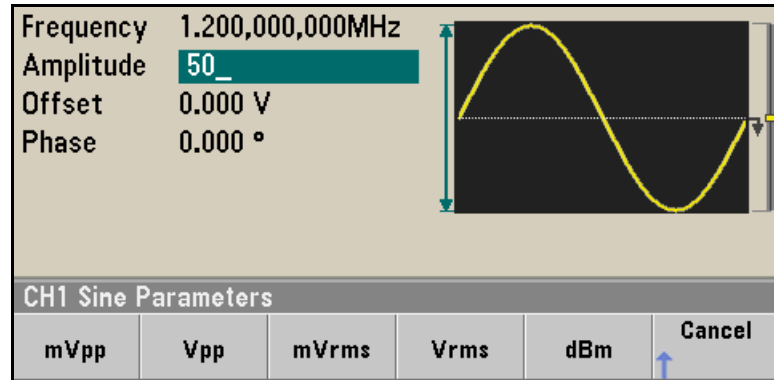
**3 Select the desired units.**

Press the softkey that corresponds to the desired units. When you select the units, the waveform generator outputs the waveform with the displayed amplitude (if the output is enabled). For this example, press **mVpp**.

Amplitude 50.000mVpp

Note: You can also enter the desired value using the knob and cursor keys. If you do so, you do not need to use a units softkey.

Chapter 1 Quick Start

To Set the Output Amplitude

You can easily convert the displayed amplitude from one unit to another. Simply press **Units**, and then press the **Ampl As** softkey and select the desired units.

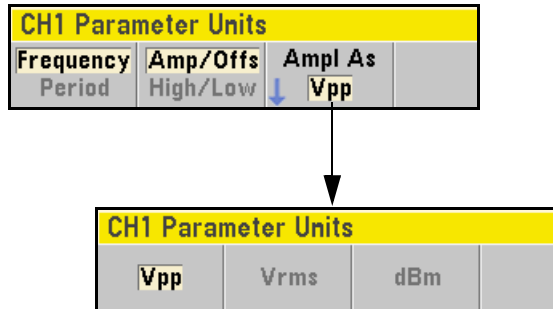

To Set a DC Offset Voltage

At power-on, the waveform generator outputs a sine wave with a DC offset of 0 volts (into a 50Ω termination). *The following steps show you how to change the offset to -1.5 VDC.*

- 1 Press **Parameters**, followed by the “Offset” softkey.

The displayed offset voltage is either the power-on value or the offset previously selected. When you change functions, the same offset is used if the present value is valid for the new function.

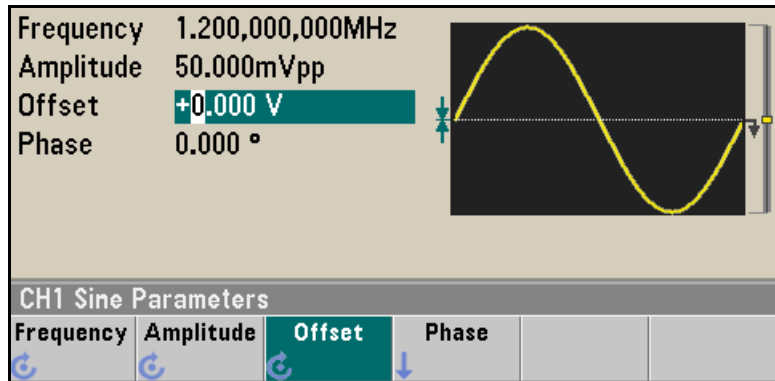

- 2 Enter the magnitude of the desired offset.

Using the numeric keypad, enter the value “ -1.5 ”.

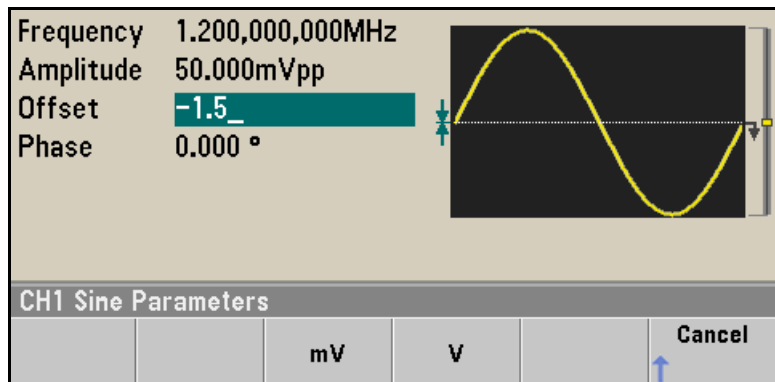

3 Select the desired units.

Press the softkey for the desired units. When you select the units, the waveform generator outputs the waveform with the displayed offset (if the output is enabled). For this example, press **V**. The voltage will be set as shown below.

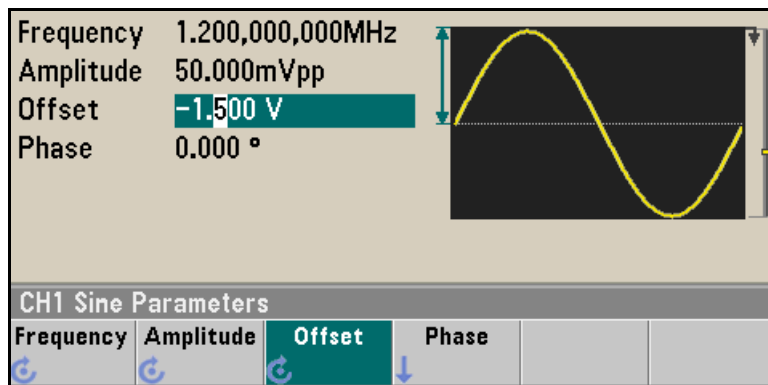

Note: You can also enter the desired value using the knob and cursor keys.

To Set the High-Level and Low-Level Values

You can specify a signal by setting its amplitude and DC offset values, as described previously. Another way to set the signal limits is to specify its high (maximum) and low (minimum) values. This is typically convenient for digital applications. In the following example, we will set the high level to 1.0 V and the low level to 0.0 V.

- 1 Press **Units**.
- 2 Press the **Amp/Offs** softkey to toggle to **High/Low** as shown below.

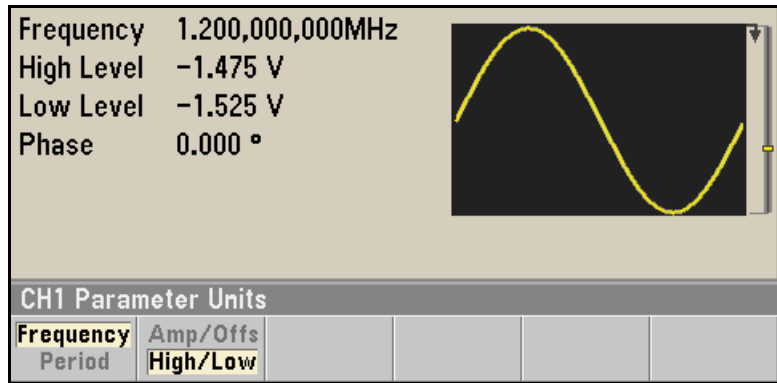

3 Set the “High Level” value.

Press the **Parameters** key and select **High Level**. Using the numeric keypad or knob and arrows, select a value of 1.0 V. (If you are using the keypad, you will need to select the **V** unit softkey to enter the value.)

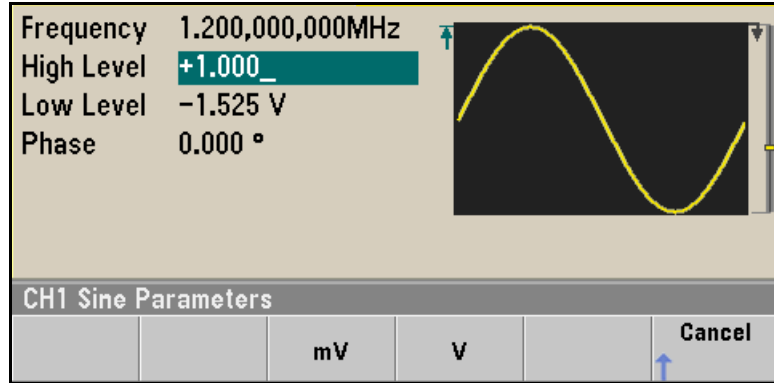

4 Press the Low Level softkey and set the value.

Again, use the numeric keypad or the knob to enter a value of 0.0 V.

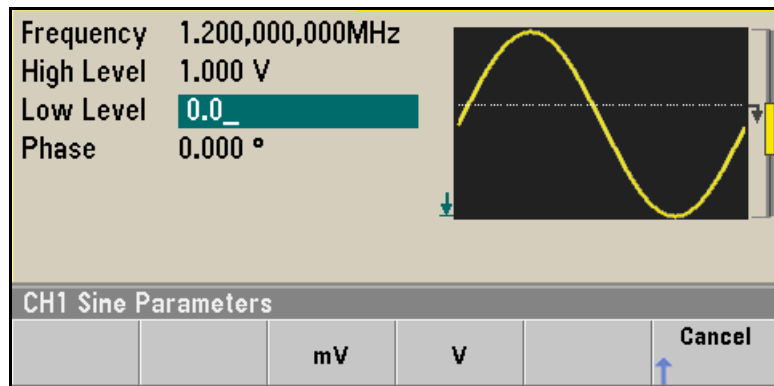

These settings (high-level = 1.0 V and low-level = 0.0 V) are equivalent to setting an amplitude of 1.0 V_{pp} and an offset of 500 mV.

To Output a DC Voltage

You can specify a constant DC voltage to be output

- 1 Press  and then select **More** and **DC**.

The **Offset** value becomes selected.

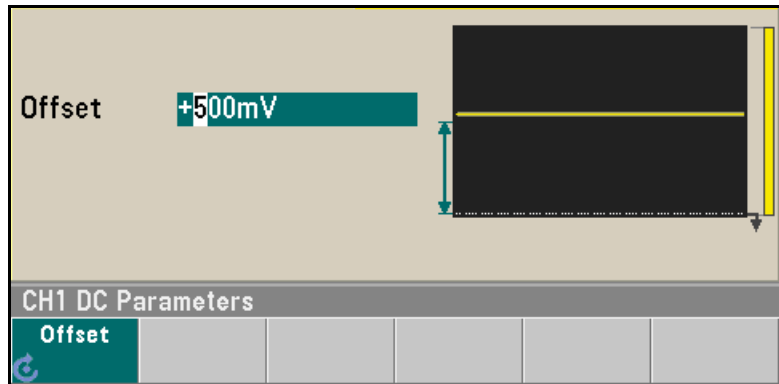

- 2 Enter the desired voltage level as an **Offset**.

Enter 1.0 with the numeric keypad or knob and then press the **V** softkey if you used the keypad.

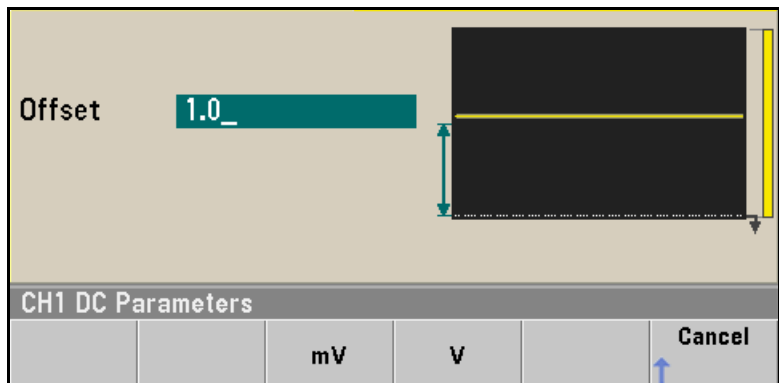

You can enter any DC voltage from -5 V to +5 V into 50 Ω , or -10 V to +10 V into a high impedance load.

To Set the Duty Cycle of a Square Wave

At power-on, the duty cycle for square waves is 50%. The duty cycle is limited by the minimum pulse width specification of 16 ns. *The following steps show you how to change the duty cycle to 75%.*

1 Select the square wave function.

Press the  key and choose **Square**.

2 Press the Duty Cycle softkey.

The displayed duty cycle is either the power-on value or the percentage previously selected. The duty cycle represents the amount of time per cycle that the square wave is at a *high* level.

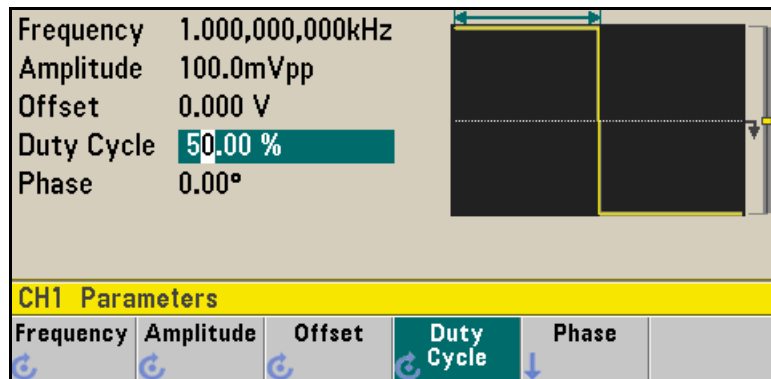

3 Enter the desired duty cycle.

Using the numeric keypad or the knob and arrows, select a duty cycle value of “75”. If you are using the numeric keypad, press the **Percent** softkey to finish the entry. The waveform generator adjusts the duty cycle immediately and outputs a square wave with the specified value (if the output is enabled).

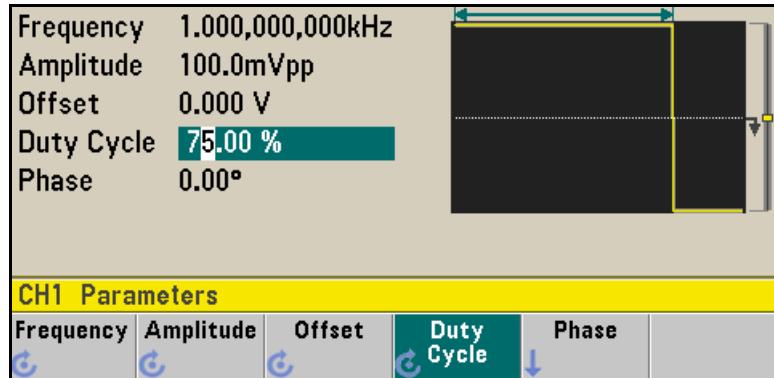

To Configure a Pulse Waveform

You can configure the waveform generator to output a pulse waveform with variable pulse width and edge time. *The following steps show you how to configure a 500 ms periodic pulse waveform with a pulse width of 10 ms and edge times of 50 ns.*

1 Select the pulse function.

Press the **Waveforms** key and choose **Pulse** to select the pulse function and output a pulse waveform with the default parameters.

2 Set the pulse period.

Press the **Units** key and then press the **Frequency/Period** softkey to choose **Period**. Then press **Parameters** and choose **Period**. Set the period to 500 ms.

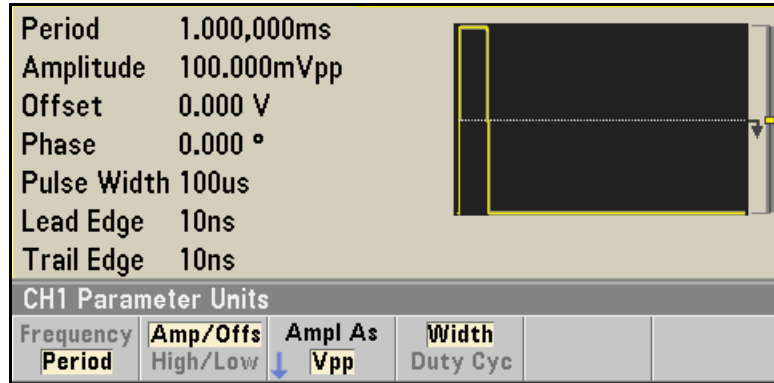

3 Set the pulse width.

Press **Parameters** and the **Pulse Width** softkey, and then set the pulse width to 10 ms. The pulse width represents the time from the 50% threshold of the rising edge to the 50% threshold of the next falling edge.

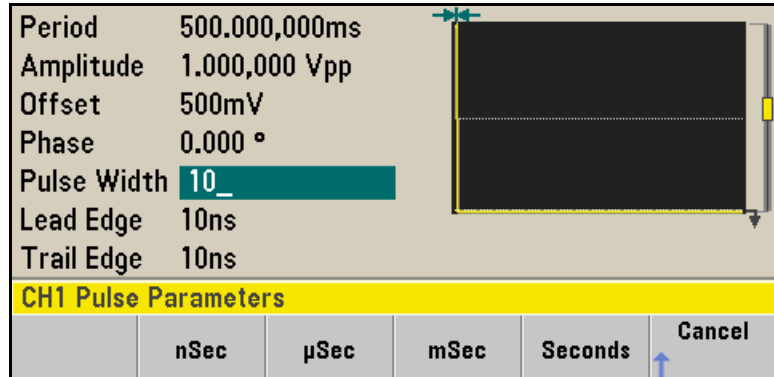

4 Set the edge time for both edges.

Press the **Edge Time** softkey and then set the edge time for *both* the leading and trailing edges to 50 ns. The edge time represents the time from the 10% threshold to the 90% threshold of each edge.



To Select a Stored Arbitrary Waveform

There are nine built-in arbitrary waveforms stored in non-volatile memory. They are Cardiac, D-Lorentz, Exponential Fall, Exponential Rise, Gaussian, Haversine, Lorentz, Negative Ramp, and Sinc.

The following steps show you how to select the built-in “exponential fall” waveform from the front panel.

For information on creating a custom arbitrary waveform, refer to “To Set up an Arbitrary Waveform” on page 73.

1 Select the arbitrary waveform function.

Press the  button and choose the **Arb** and **Arbs** softkeys. Then choose **Select Arb** and use the knob to select **Exp_Fall**. Press **Select**.

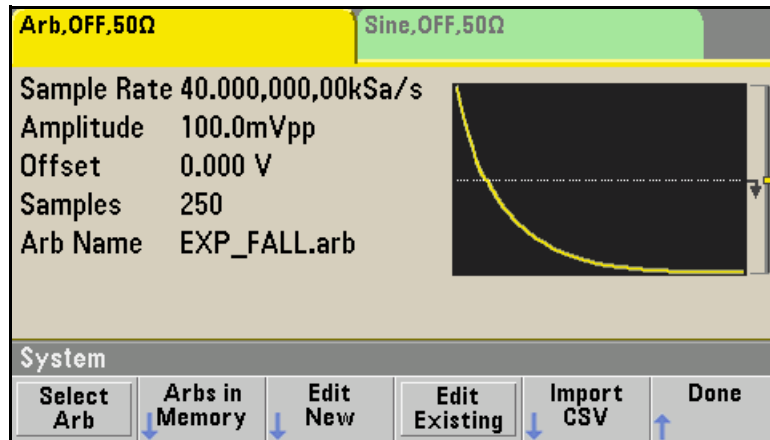

To Use the Built-In Help System

The built-in help system is designed to provide context-sensitive assistance on any front-panel key or menu softkey. A list of help topics is also available to assist you with several front-panel operations.

1 View the help information for a function key.

Press and hold down any softkey or button such as . If the message contains more information than will fit on the display, press the ↓ softkey or use the knob to view the remaining information.

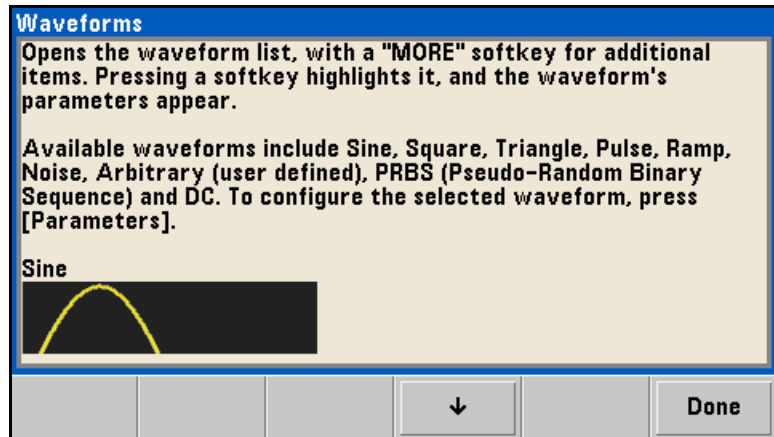

Press **Done** to exit Help.

2 View the list of help topics.

Press the **System** button and then press **Help** to view the list of available help topics. To scroll through the list, press the **↑** and **↓** softkeys or use the knob. Select the topic **Get HELP on any key** and then press **Select**.

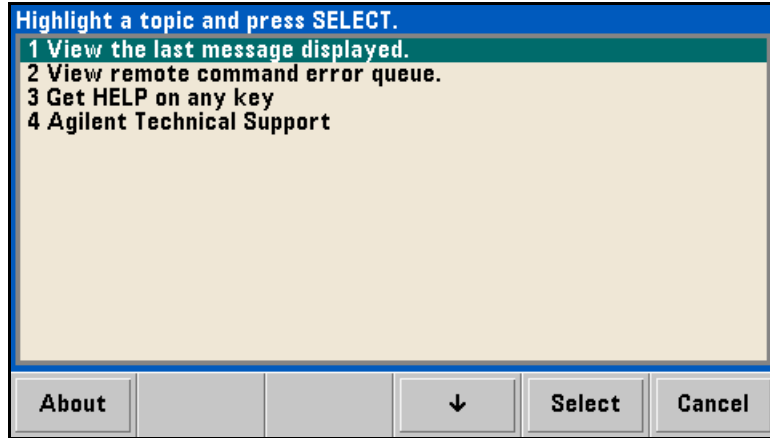

Press **Done** to exit Help.

3 View the help information for displayed messages.

Whenever a limit is exceeded or any other invalid configuration is found, the waveform generator will display a message. The built-in help system provides additional information on the most recent message.

Press the **System** button and then press **Help**. Then select the topic **View the last message displayed**, and press **Select**.

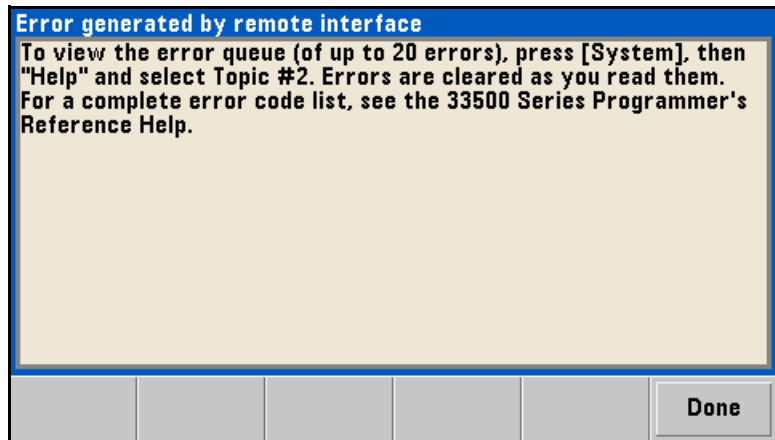

Press **Done** to exit Help.

Local Language Help: The built-in help system is available in Chinese, French, German, Japanese, and Korean. All messages, context-sensitive help, and help topics appear in the selected language. The menu softkey labels and status line messages are not translated.

To select the local language, press the **System** button, then press the **System Setup** softkey, the **User Settings** softkey, and the **Help Lang** softkey. Then select the desired language.

To Rack Mount the Waveform Generator

You can mount the instrument in a standard 19-inch rack cabinet using one of two optional kits available. Instructions and mounting hardware are included with each rack-mounting kit. Any Agilent *System II* instrument of the same size can be rack-mounted beside the Agilent 33500 Series.

Note: Remove the carrying handle, and the front and rear rubber bumpers, before rack-mounting the instrument.

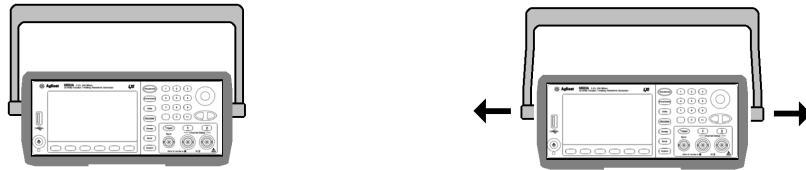

To remove the handle, rotate it to vertical and pull the ends outward.

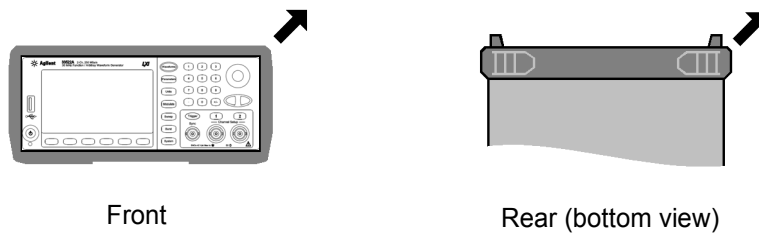

Front

Rear (bottom view)

To remove the rubber bumper, stretch a corner and then slide it off.

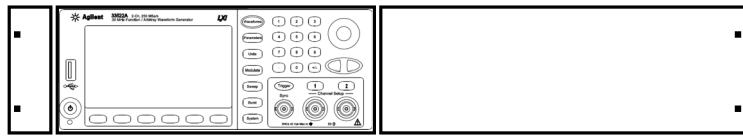

To rack mount a single instrument, order adapter kit 5063-9240.

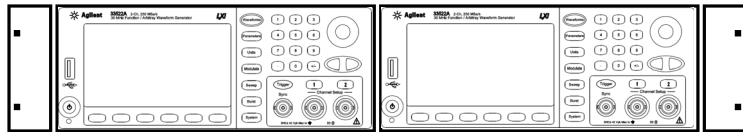

To rack mount two instruments side-by-side, order lock-link kit 5061- 8769 and flange kit 5063-9212. Be sure to use the support rails in the rack cabinet.

In order to prevent overheating, do not block the flow of air into or out of the instrument. Be sure to allow enough clearance at the rear, sides, and bottom of the instrument to permit adequate internal air flow.

Chapter 1 Quick Start
To Rack Mount the Waveform Generator

1

Front-Panel Menu Operation

Front-Panel Menu Operation

This chapter introduces you to the front-panel keys and menu operation. This chapter does not give a detailed description of every front-panel key or menu operation. It does, however, give you an overview of the front-panel menus and many front-panel operations. See chapter 3 “Features and Functions,” starting on page 89, for a complete discussion of the waveform generator’s capabilities and operation.

2

- Front-Panel Menu Reference, *on page 43*
- To Select the Output Termination, *on page 47*
- To Reset the Waveform Generator, *on page 48*
- To Output a Modulated Waveform, *on page 49*
- To Output an FSK Waveform, *on page 51*
- To Output a PWM Waveform, *on page 53*
- To Output a Frequency Sweep, *on page 56*
- To Output a Burst Waveform, *on page 59*
- To Trigger a Sweep or Burst, *on page 62*
- To Store the Instrument State, *on page 63*
- To Configure the Remote Interface, *on page 65*
- To Set up an Arbitrary Waveform, *on page 73*

Front-Panel Menu Reference

This section gives an overview of the front-panel menus. The remainder of this chapter contains examples of using the front-panel menus.



Select a waveform

- Select one of nine waveform types, including Sine, Square, Ramp, Pulse, Arbitrary, Triangle, Noise, PRBS, and DC.



Configure parameters for the selected waveform

Depending on the waveform, you can do some of the various tasks:

- Configure Period/Frequency
- Configure Amplitude
- Configure Offset
- Configure Phase
- Configure Duty Cycle
- Configure Symmetry
- Configure Pulse Width
- Configure Edge Times
- Configure Arbitrary Waveforms
- Configure Bandwidth
- Configure PRBS Data
- Configure Bit Rate



Specify what units and parameters to use for various waveforms.

- Specify whether to use Frequency or Period
- Specify whether to use Amplitude and Offset or High and Low Voltage
- Specify which voltage units to use
- Specify whether to use Width or Duty Cycle
- Specify whether to configure Frequency sweep as Center/Span or Start/Stop

Modulate **Configure the parameters for modulation.**

- Turn modulation on or off.
- Specify the modulation type.
- Specify the modulation source.
- Specify parameters for AM, FM, PM, PWM, BPSK, FSK and Sum modulation.

Sweep **Configure the parameters for frequency sweep.**

- Turn sweep on or off.
- Select linear, logarithmic or frequency list sweeping.
- View and edit a list of frequencies to sweep.
- Select the time in seconds required to complete a sweep.
- Select the start/stop frequencies or center/span frequencies.
- Specify dwell, hold, and return times.

Burst **Configure the parameters for burst.**

- Turn burst on or off.
- Select the triggered (N Cycle) or externally-gated burst mode.
- Select the number of cycles per burst (1 to 100,000,000 or infinite).
- Select the starting phase angle of the burst (-360° to +360°).
- Specify the number of cycles.
- Specify the burst period.

System **Store/Recall - Store and recall instrument states.**

- Store an arbitrary number of instrument states in non-volatile memory.
- Assign a custom name to each storage location.
- Recall stored instrument states.
- Delete stored instrument states.
- Restore all instrument settings to their factory default values.
- Select the instrument's power-on configuration (last or factory default).

System

I/O Config - Configure instrument I/O interfaces.

- Turn the LAN on and off.
- Specify the LAN configuration (IP address and network configuration).
- Reset the LAN.
- Specify the USB settings.
- Select the GPIB address.

System

Calibrate - Perform calibration tasks.

- Set the calibration password.
- Lock and unlock the instrument for calibration.
- Calibrate the instrument (see *Agilent 33500 Series Service Guide*).

System

Instr Setup - Configure instrument parameters.

- Perform self-test.
- Configure reference oscillator.
- Clear instrument memory (NISPOM secure).

System

System Setup - Configure system-related parameters.

- Set screen layout.
- Select the local language for front-panel messages and help text.
- Select how periods and commas are used in numbers displayed on the front panel.
- Turn the display on and off.
- Enable/disable the beeper heard when an error is generated.
- Enable/disable the display screen saver mode.
- Adjust the brightness setting of the front-panel display.
- Install licenses for licensed features.
- Set date and time.
- Perform file management.

System

Help - View the list of Help topics.

- View the last message displayed.
- View the remote command error queue.
- Get help on any key.
- Learn how to obtain Agilent Technical Support.
- View “about” data - serial number, IP address, firmware version, and so on.

Channel

or 1

or 2

Channels - Enable and configure channels.

- Turn channel on and off
- Select the output termination (1 Ω to 10 k Ω , or Infinite).
- Enable/disable amplitude autoranging.
- Select the waveform polarity (normal or inverted).
- Specify voltage limits on channel.
- Specify whether the channel is to be in normal or gated mode.
- Configure the channel for dual channel operation (33522A).

Trigger

Configure Trigger Settings

- Specify the trigger source for the sweep, burst or arbitrary waveform advance.
- Specify the trigger count and delay.
- Specify the slope (rising or falling edge) for an external trigger source.
- Specify the slope (rising or falling edge) of the “Trig Out” signal.
- Enable/disable the Sync signal which is output from the “Sync” connector.

To Select the Output Termination

The Agilent 33500 Series has a fixed series output impedance of 50 Ω to the front-panel channel connectors. If the actual load impedance is different than the value specified, the displayed amplitude and offset levels will be incorrect. The load impedance setting is simply provided as a convenience to ensure that the displayed voltage matches the expected load.

- 1 Press **Channel** or **1** or **2** to open the channel configuration screen. Note that the current output termination values (both 50 Ω in this case) appear on the tabs at the top of the screen.
- 2 Specify the output termination.

Press the **Output Load** softkey.

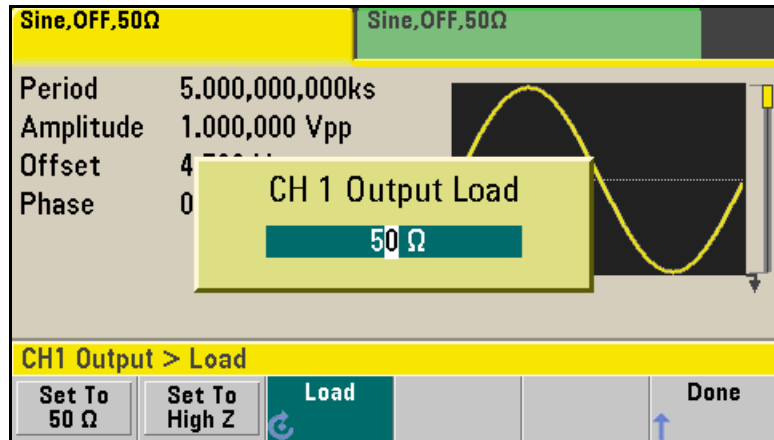

- 3 Select the desired output termination.

Use the knob or numeric keypad to select the desired load impedance or press the **Set to 50 Ω** softkey or the **Set to High Z** softkey.

To Reset the Waveform Generator

To reset the instrument to its factory default state, press  and then select the **Store/Recall** and **Set to Defaults** softkeys.

For a complete listing of the instrument's power-on and reset conditions, see "Agilent 33500 Series Factory Default Settings" on page 216.

To Output a Modulated Waveform

A modulated waveform consists of a *carrier* and a *modulating waveform*. In AM (amplitude modulation), the amplitude of the carrier is varied by the modulating waveform. For this example, you will output an AM waveform with 80% modulation depth. The carrier will be a 5 kHz sine wave and the modulating waveform will be a 200 Hz sine wave.

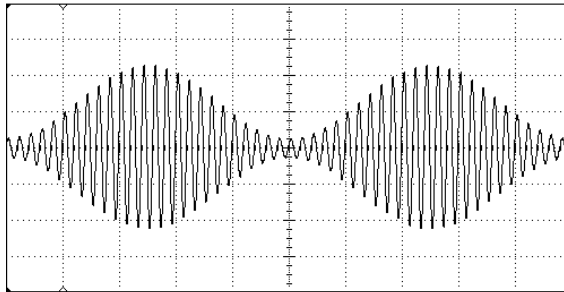

1 Select the function, frequency, and amplitude of the carrier.

Press **Waveforms** and then press the **Sine** softkey. Press the **Frequency**, **Amplitude**, and **Offset** softkeys to configure the carrier waveform. *For this example, select a 5 kHz sine wave with an amplitude of 5 Vpp, with 0 V offset.*

2 Select AM.

Press **Modulate** and then select “AM” using the **Type** softkey. Then press the **Modulate** softkey to turn modulation On. Notice that the **Modulate** button is illuminated, and the status message “AM Modulated by Sine” appears at the top left of the display.

3 Set the modulation depth.

Press the **AM Depth** softkey and then set the value to 80% using the numeric keypad or the knob and cursor keys.

4 Select the modulating waveform shape.

Press the **Shape** softkey to select the shape of the modulating waveform. For this example, select a sine wave.

5 Set the modulating frequency.

Press **More** and then the **AM Freq** softkey. Set the value to 200 Hz using the numeric keypad or the knob and cursor keys. Press the **Hz** softkey to finish entering the number if you are using the numeric keypad.

At this point, the waveform generator outputs an AM waveform with the specified modulation parameters.

To Output an FSK Waveform

You can configure the waveform generator to “shift” its output frequency between two preset values using FSK modulation. The rate at which the shift happens is the FSK rate, and this FSK rate is determined by the internal rate generator or the signal level on the rear-panel *Ext Trig* connector. The two frequencies that the signal shifts between are called the “carrier frequency” and the “hop frequency.” *For this example, you will set the “carrier” frequency to 3 kHz and the “hop” frequency to 500 Hz, with an FSK rate of 100 Hz.*

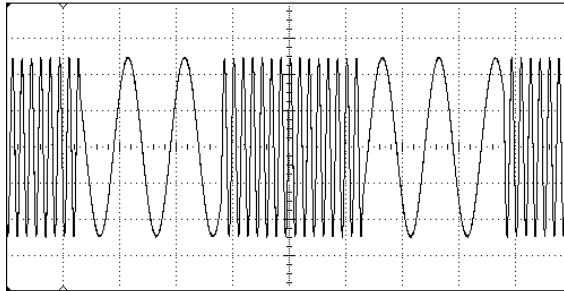

1 Select the function, frequency, and amplitude of the carrier.

Press **Waveforms** and then press the **Sine** softkey. Press the **Frequency**, **Amplitude**, and **Offset** softkeys to configure the carrier waveform. *For this example, select a 3 kHz sine wave with an amplitude of 5 Vpp, with 0 offset.*

2 Select FSK.

Press **Modulate** and then select **FSK** using the **Type** softkey. Then press the **Modulate** softkey to turn modulation On. Notice the status message “FSK Modulated” at the top left of the display.

3 Set the “hop” frequency.

Press the **Hop Freq** softkey and then set the value to 500 Hz using the numeric keypad or the knob and cursor keys. If you use the numeric keypad, be sure to finish the entry by pressing the **HZ** softkey.

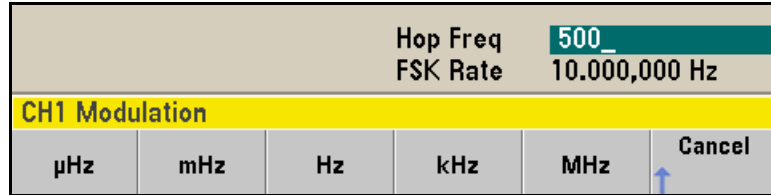

4 Set the FSK “shift” rate.

Press the **FSK Rate** softkey and then set the value to 100 Hz using the numeric keypad or the knob and cursor keys.

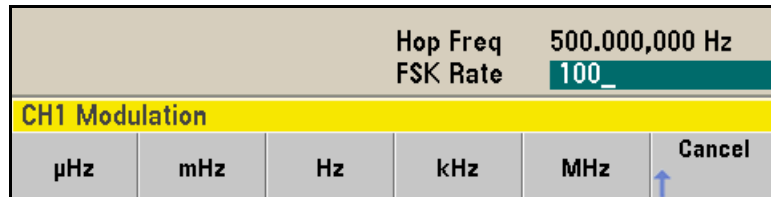

At this point, the waveform generator outputs an FSK waveform.

To Output a PWM Waveform

You can configure the waveform generator to output a pulse width modulated (PWM) waveform. The Agilent 33500 Series provides PWM for pulse carrier waveforms. In PWM, the pulse width or duty cycle of the carrier waveform is varied according to the modulating waveform. You can specify either a pulse width and width deviation, or a pulse duty cycle and duty cycle deviation, the deviation to be controlled by the modulating waveform.

For this example, you will specify a pulse width and pulse width deviation for a 1 kHz pulse waveform with a 5Hz sine wave modulating waveform.

1 Select the carrier waveform parameters.

Press **Waveforms** and then press **Pulse**. Use the **Frequency**, **Amplitude**, **Offset**, **Pulse Width** and **Edge Times** softkeys to configure the carrier waveform. For this example, select a 1 kHz pulse waveform with an amplitude of 1 Vpp, zero offset, a pulse width of 100 μ s, and an edge time of 50 ns (both leading and trailing).

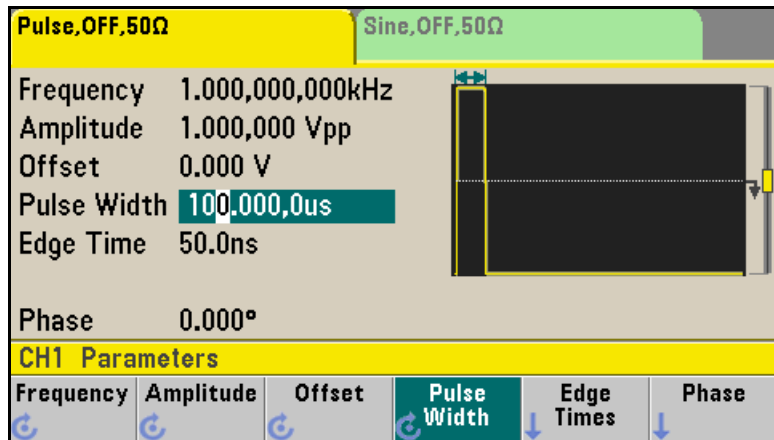

2

2 Select PWM.

Press **Modulate** and choose **Type**, then **PWM**. Then press the first softkey (**Modulate**) to turn modulation on. Notice the status message “PWM Modulated by Sine” in the upper-left corner of the display.

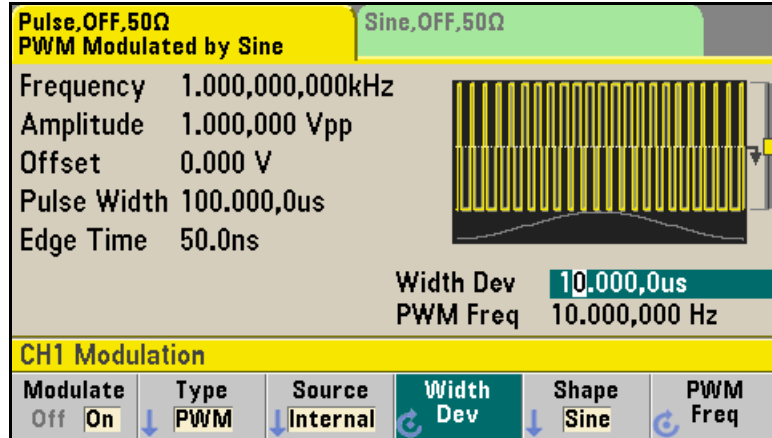

3 Set the width deviation.

Press the **Width Dev** softkey and set the value to 20 μ s using the numeric keypad or the knob and cursor keys.



4 Set the modulating frequency.

Press the **PWM Freq** softkey and then set the value to 5 Hz using the numeric keypad or the knob and cursor keys.

					Width Dev	20.000,0us
					PWM Freq	5.000,000 Hz
CH1 Modulation						
Modulate	Type	Source	Width Dev	Shape	PWM Freq	
Off On	↓ PWM	↓ Internal	↻ Dev	↓ Sine	↻ Freq	

5 Select the modulating waveform shape.

Press the **Shape** softkey to select the shape of the modulating waveform. For this example, select a sine wave.

At this point, the waveform generator outputs a PWM waveform with the specified modulation parameters (if the output is enabled).

Of course, to really view the PWM waveform, you would need to output it to an oscilloscope. If you do this, you will see how the pulse width varies, in this case, from 80 to 120 μ s. At a modulation frequency of 5 Hz, the deviation is quite visible.

To Output a Frequency Sweep

In the frequency sweep mode, the waveform generator moves from the *start frequency* to the *stop frequency* at a *sweep rate* which you specify. You can sweep up or down in frequency, and with either linear or logarithmic spacing, or using a list of frequencies. *For this example, you will output a swept sine wave from 50 Hz to 5 kHz.*

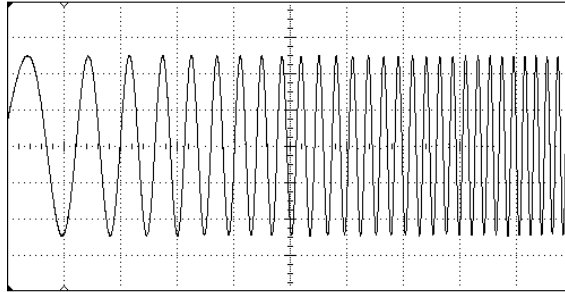

1 Select the function and amplitude for the sweep.

For sweeps, you can select sine, square, ramp, pulse, triangle, or PRBS waveforms (arbitrary waveforms, noise, and DC are not allowed). *For this example, select a sine wave with an amplitude of 5 Vpp.*

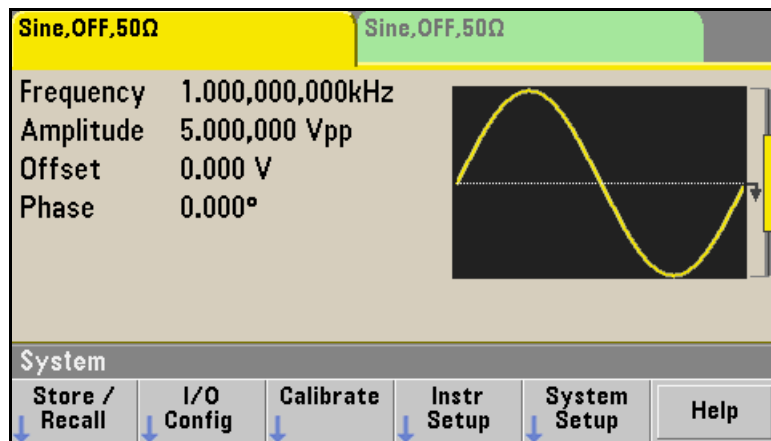

2 Select the sweep mode.

Press **Sweep** and then verify that the linear sweep mode is currently selected on the second softkey. Press the **Sweep** softkey to turn sweep on. Notice the “Linear Sweep” status message at the top of the tab for the current channel. The **Sweep** button is also illuminated.

3 Set the start frequency.

Press the **Start Freq** softkey and then set the value to 50 Hz using the numeric keypad or the knob and cursor keys.

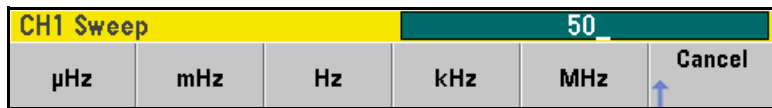

4 Set the stop frequency.

Press the **Stop Freq** softkey and then set the value to 5 kHz using the numeric keypad or the knob and cursor keys. *At this point, the waveform generator outputs a continuous sweep from 50 Hz to 5 kHz if output is enabled.*

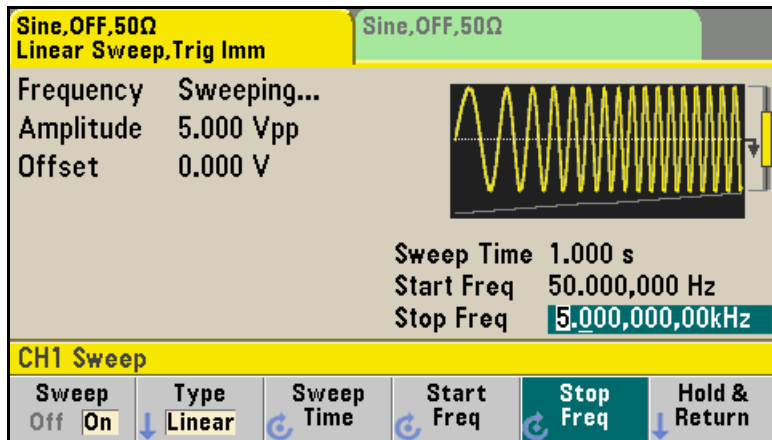

To Output a Frequency Sweep

Note: If desired, you can press the **Units** button and then press the fourth softkey to set the frequency boundaries of the sweep using a *center frequency* and *frequency span*. These parameters are similar to the start frequency and stop frequency and are included to give you added flexibility. To achieve the same results, set the center frequency to 2.525 kHz and the frequency span to 4.950 kHz.

CH1 Parameter Units					
Frequency	Amp/Offs	Ampl As	Start/Stop		
Period	High/Low	↓ Vpp	Cntr/Span		

To generate a frequency sweep, press **Trigger** twice. The first press puts the trigger in manual mode, and the second one sends a trigger. For more information, see “To Trigger a Sweep or Burst” on page 62.

To Output a Burst Waveform

You can use the waveform generator to output a waveform with a specified number of cycles, called a *burst*. You can control the amount of time that elapses between bursts with the internal timer or the signal level on the rear-panel *Ext Trig* connector. *For this example, you will output a three-cycle sine wave with a 20 ms burst period.*

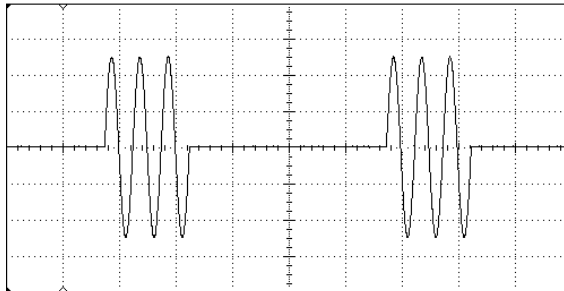

1 Select the function and amplitude for the burst.

For burst waveforms, you can select sine, square, ramp, pulse, arbitrary waveforms, triangle, or PRBS. Noise is allowed only in the “gated” burst mode and DC is not allowed. *For this example, select a sine wave with an amplitude of 5 Vpp.*

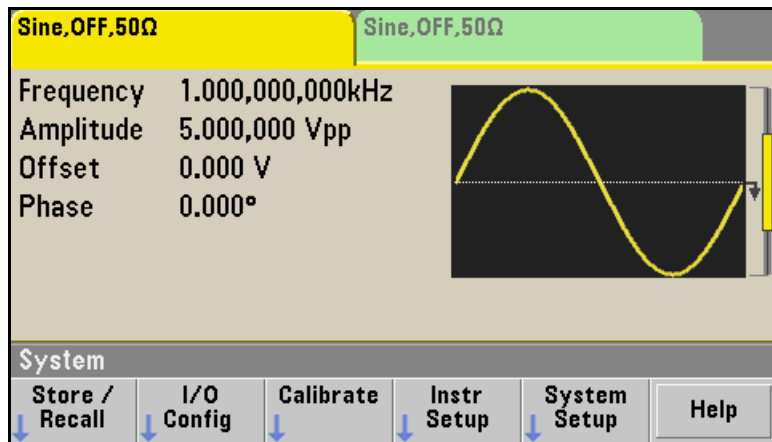

2 Select the burst mode.

Press **Burst** and then press the **Burst Off / On** softkey. Notice that a status message “N Cycle Burst, Trig Imm” is shown in the tab of the current channel.

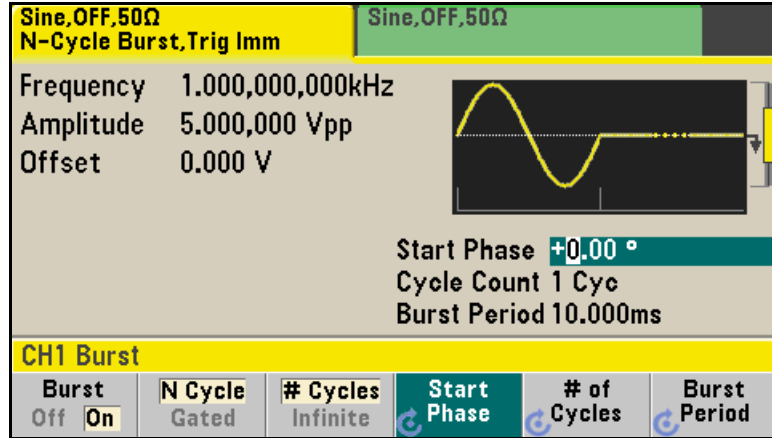

3 Set the burst count.

Press the **# of Cycles** softkey and then set the count to “3” using the numeric keypad or knob. Press the **Enter** softkey to finish data entry if you are using the numeric keypad.

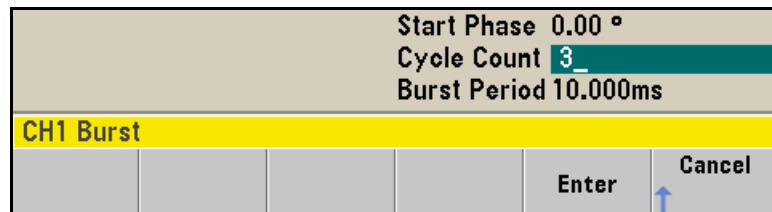

4 Set the burst period.

Press the **Burst Period** softkey and then set the period to 20 ms using the numeric keypad or the knob and cursor keys. The burst period sets the time from the start of one burst to the start of the next burst.

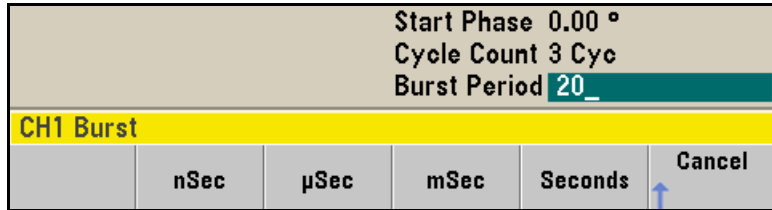

At this point, the waveform generator outputs a continuous three-cycle burst at 20 ms intervals.





You can generate a single burst (with the specified count) by pressing the **Trigger** key. For more information, see “To Trigger a Sweep or Burst” on page 62.

You can also use the external gate signal to create gated bursts, where a burst is produced while a gate signal is present on the input.

To Trigger a Sweep or Burst

You can issue triggers from the front panel for sweeps and bursts using one of four different trigger types.

- *Immediate* or “automatic” triggering is the default setting. In this mode, the waveform generator outputs continuously when the sweep or burst mode is selected.
- *Ext* or “external” triggering controls triggering via the Trigger connector on the rear of the instrument.
- *Manual* triggering initiates one sweep or outputs one burst each time you press the  button. Continue pressing this key to re-trigger the waveform generator.
- *Timer* issues one or more triggers separated in time by a fixed amount.

If sweep or burst is on, pressing  will display the trigger menu. The  key is illuminated when you are in the trigger menu and the waveform generator is waiting for a manual trigger. The  key blinks when the waveform generator is waiting for a manual trigger, but you are not in the trigger menu. The  key is disabled when the instrument is in remote.

Pressing  while you are in the trigger menu will send a manual trigger if the trigger source is set to manual.

To Store the Instrument State

You can store instrument states in any number of state files, which always have a .sta extension. You can do this for backup purposes, or you can save your state to a USB drive and then reload the state on a different instrument in order to have instruments with matching configurations.

1 Select the desired storage location.

Press **System** and then press the **Store / Recall** softkey, followed by the **Store State** softkey.

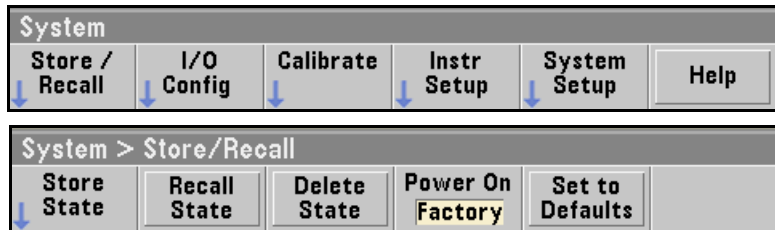

2 Specify the name for the selected location.

Use the knob and arrows to enter the file name.

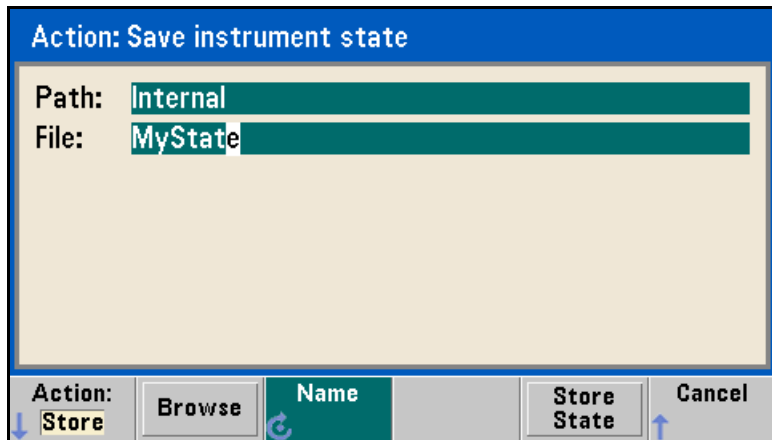

- To add characters, press the right-cursor key until the cursor is to the right of the existing name and then turn the knob.

To Store the Instrument State

- To delete a character, rotate the knob until you get to the blank character before the capital A.
- To delete all characters from the cursor position to the end of the line, press the +/- key.
- To use numbers in the name, you can enter them directly from the numeric keypad.

3 Store the instrument state.

Press the **STORE STATE** softkey. A stored state contains the selected function, frequency, amplitude, DC offset, duty cycle, symmetry, as well as any modulation parameters in use. The instrument *does not* store volatile waveforms created in the arbitrary waveform function.

4 Recall the instrument state (optional).

If at some later time you wish to restore (retrieve) a stored state, press  and then **Store / Recall**. Then press **Recall State**, select the state to recall and press **Select**.

To Configure the Remote Interface

The Agilent 33500 Series supports remote interface communication using a choice of three interfaces: GPIB (optional), USB, and LAN (LXI Class C compliant). All three interfaces are “live” at power up. The following sections explain how to configure the remote interface from the instrument front panel.

Note: *Two CDs, provided with your instrument, contain connectivity software to enable communications over the remote interfaces. See “Connectivity Software and Product CDs” on page 178 for further information on these CDs and the software they contain.*

GPIB Configuration (Option 400)

You need only select a GPIB address.

1 Select the “I/O” menu.

Press **System** and then press the **I/O Config** and **GPIB Settings** softkeys. Then press the **GP-IB Address** softkey.

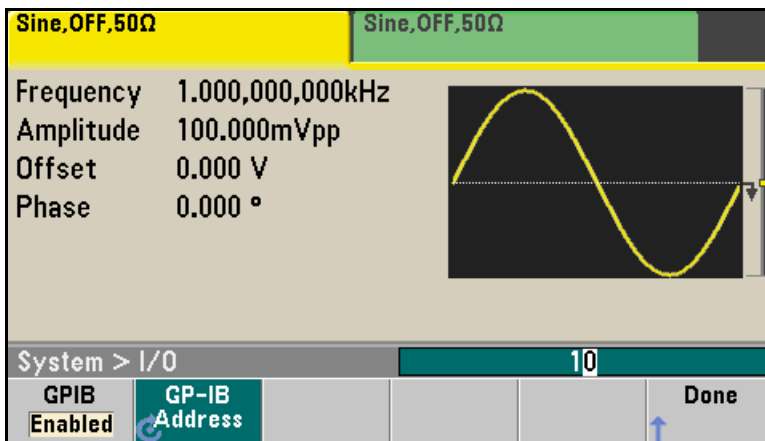

2 Set the GPIB address.

Use the knob and cursor keys or the numeric keypad to select a GPIB address in the range 0 through 30 (the factory default is “10”). Press **Enter** when done if you are using the numeric keypad.

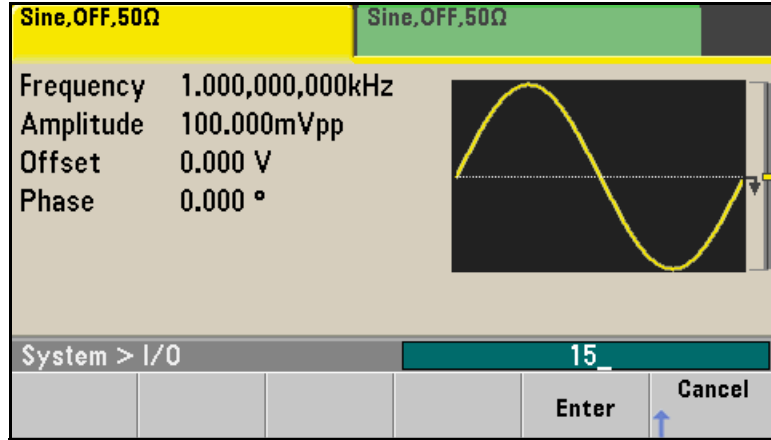

USB Configuration

The USB interface requires no front panel configuration parameters. Just connect the Agilent 33500 Series to your PC with the appropriate USB cable. The interface will configure itself. The instrument supports both USB 1.1 and USB 2.0.

LAN Configuration

There are several parameters that you might need to set to establish network communication using the LAN interface. Primarily, you will need to establish an IP address. You might need to contact your network administrator for help in establishing communication with the LAN interface.

1 Select the “I/O” menu.

Press  and then press the **I/O Config** softkey.

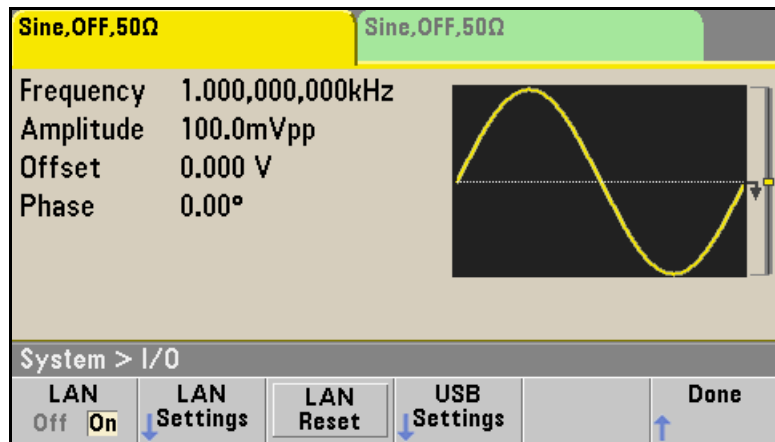

2 Select the **LAN Settings** menu.

Press the **LAN Settings** softkey.

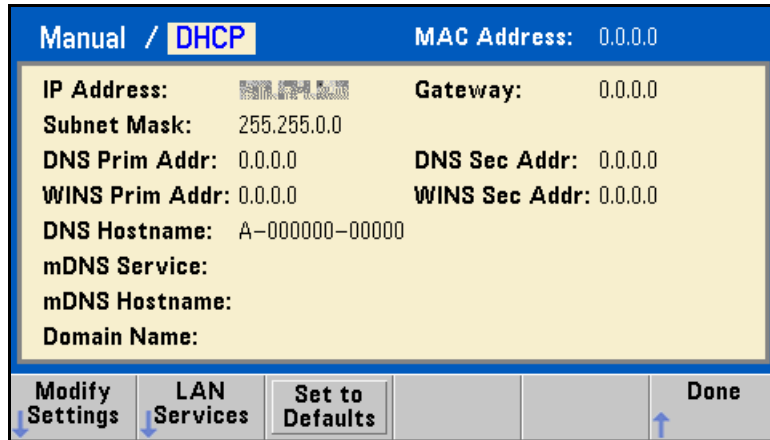

You can select **Modify Settings** to change the LAN settings, or you can turn LAN Services on and off or restore the LAN settings to default values.

3 Press **Modify Settings**.

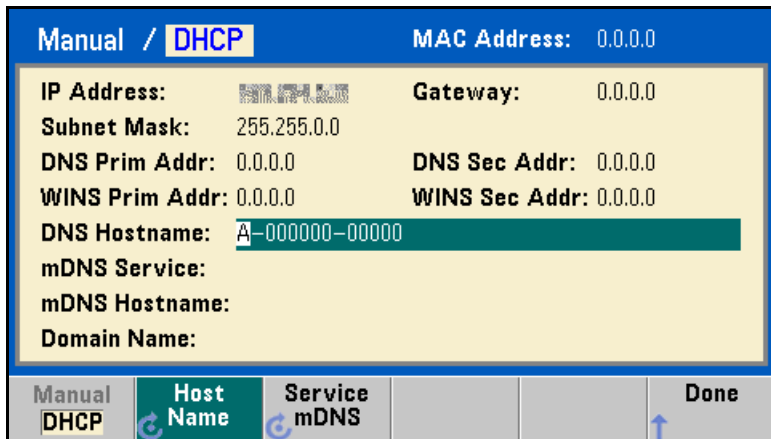

To access most items on this screen, you must use the first softkey to switch from **DHCP** to **Manual**. With **DHCP** on, an IP address will automatically be set by DHCP (Dynamic Host Configuration Protocol) when you connect the instrument to the network, provided the DHCP server is found and is able to do so. DHCP also automatically deals with the subnet mask and gateway address, if required. *This is typically the easiest way to establish LAN communication for your instrument. All you need to do is leave **DHCP** on. Contact your LAN administrator for more information.*

4 Establish an “IP Setup.”

If you are not using DHCP (if you have pressed the first softkey to switch **DHCP** to **Manual**), you must establish an IP setup, including an IP address, and possibly a subnet mask and gateway address. The **IP Address** and **Subnet Mask** buttons are on the main screen, and you press **More** to get to the **Gateway** configuration feature.

The screenshot shows a 'Manual Configuration' screen with a blue header. The main area is yellow and contains the following fields:

IP Address:	254. 5. 21	MAC Address:	0.0.0.0
Subnet Mask:	255.255.0.0	Gateway:	0.0.0.0
DNS Prim Addr:	0.0.0.0	DNS Sec Addr:	0.0.0.0
WINS Prim Addr:	0.0.0.0	WINS Sec Addr:	0.0.0.0
Host Name:	A		
mDNS Service:			

At the bottom, there is a navigation bar with six buttons: Manual DHCP, Host Name, IP Address (highlighted in green), Subnet Mask, Done, and More (1 of 3).

Contact your network administrator for the IP address, subnet mask, and gateway to use. All IP addresses take the *dot-notation* form “nnn.nnn.nnn.nnn” where “nnn” in each case is a byte value in the range 0 through 255. You can enter a new IP address using the numeric keypad (not the knob). Just type in the numbers and the period delimiters using the keypad. Use the left cursor key as a backspace key. *Do not enter leading zeros*. For further information, see “More about IP Addresses and Dot Notation” at the end of this section.

5 Configure the “DNS Setup” (optional).

DNS (Domain Name Service) is an Internet service that translates domain names into IP addresses. Ask your network administrator whether DNS is in use, and if it is, for the host name, domain name, and DNS server address to use.

- a. **Set the “Host Name.”** Press the **Host Name** softkey and enter the host name. The host name is the host portion of the domain name, which is translated into an IP address. The host name is entered as a string using the knob and cursor keys to select and change characters. The host name may include letters, numbers, and dashes (“-”). You can use the keypad for the numeric characters only.
- b. **Set the “DNS Server” addresses.** From the LAN configuration screen, press **More** to go to the second of the three pages.

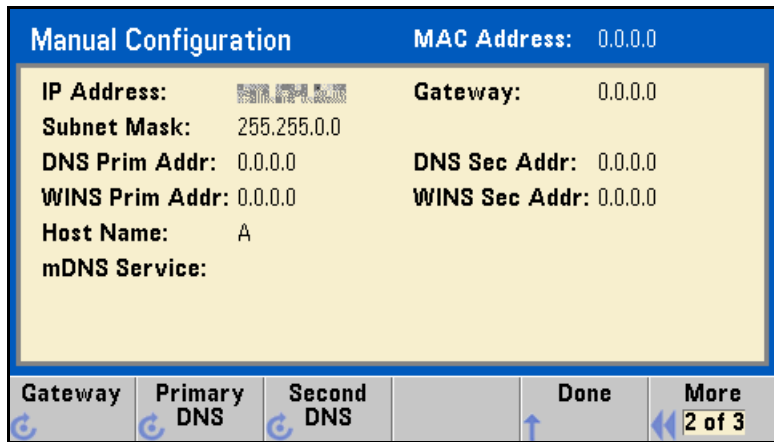

Enter the **Primary DNS** and **Second DNS**. See your network administrator for details.

More about IP Addresses and Dot Notation

Dot-notation addresses (“nnn.nnn.nnn.nnn” where “nnn” is a byte value) such as IP addresses must be expressed with care. This is because most web software on the PC will interpret byte values with leading zeros as octal numbers. Thus, “255.255.020.011” is actually equivalent to the decimal “255.255.16.9” rather than “255.255.20.11” because “.020” is interpreted as “16” expressed in octal, and “.011” as “9”. To avoid confusion it is best to use only decimal expressions of byte values (0 to 255), with no leading zeros.

The Agilent 33500 Series assumes that all IP addresses and other dot-notation addresses are expressed as decimal byte values, and strips all leading zeros from these byte values. Thus, if you try to enter “255.255.020.011” in the IP address field, it becomes “255.255.20.11” (a purely decimal expression). You should enter exactly the same expression, “255.255.20.11” in your PC web software to address the instrument. Do not use “255.255.020.011”—the PC will interpret that address differently due to the leading zeros.

To Set up an Arbitrary Waveform

The Agilent 33500 Series includes an embedded waveform editor that allows you to create and edit arbitrary waveforms. You can create these waveforms by editing voltage values directly or by using any combination of up to 12 different kinds of standard waveforms.

The following tutorial shows you how to create and edit a basic waveform.

Insert Built-in Waveforms

- 1 Start the embedded waveform editor by pressing  and **Arb**, then **Arbs**. Press **Edit New**, accept the default file name, and then **Start Editor**. You now have a 0 VDC waveform of exactly 8 points.

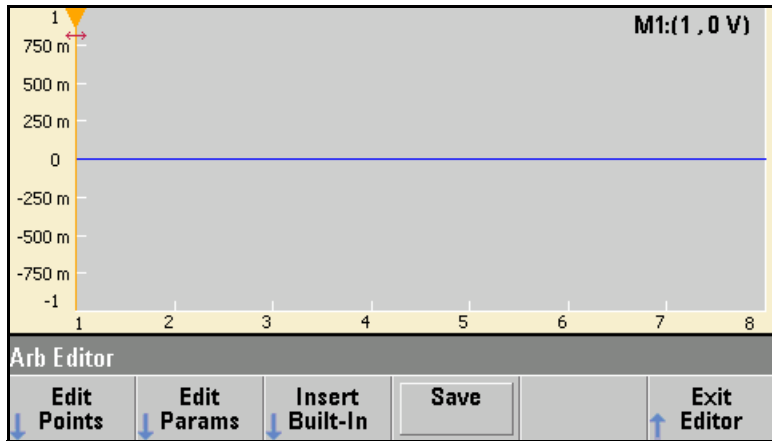

- 2 Press **Insert Built-in**, then **Choose Wave**. Use the knob or the arrows below the knob to select **D-Lorentz** and press **OK**. Use the keypad and the **V** softkey that appears when you start typing on the keypad to set the **Amplitude** to **2 V**, then press **OK**. The waveform now has 108 points, as the **D-Lorentz** waveform of 100 points was inserted in front of the initial 8 points.



- 3 Suppose that you want to undo the change that you just made. Press **System**, then the **Undo** softkey. You are now back to the original 8 point, 0 V waveform.

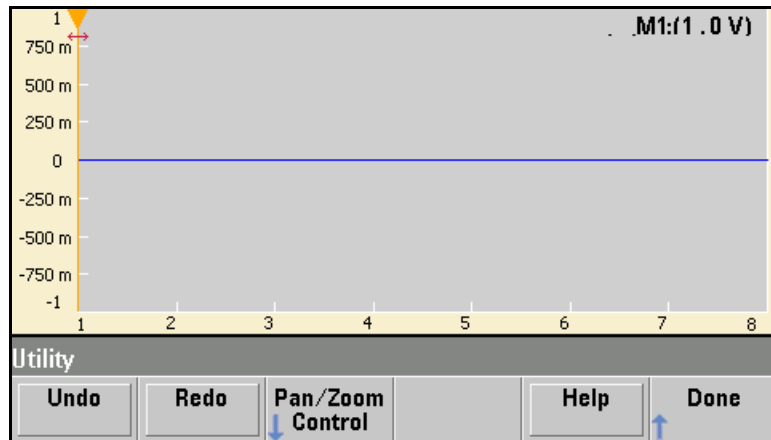

- 4 To put the D-Lorentz waveform back, press **Redo**. Then press **Done** to exit.



- 5 Now we will insert a sine wave. Begin by pressing **Choose Wave**. Make sure **Sine** (the default) is highlighted, and press **OK**. For help in understanding the various parameters on the screen, press **Parameter Help**. Then press **Done** to exit the help screen.

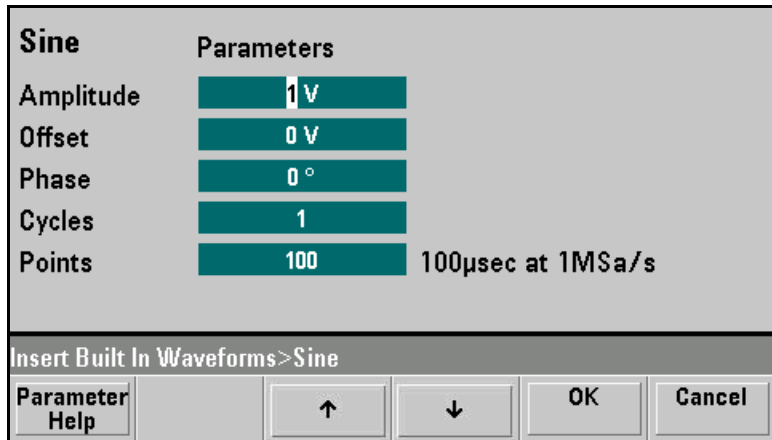

- 6 Using the numeric keypad and the up and down arrow softkeys, set the Amplitude to 3.5 V, the Cycles to 4, and the Points to 200. Leave all other settings at their default values and press OK.

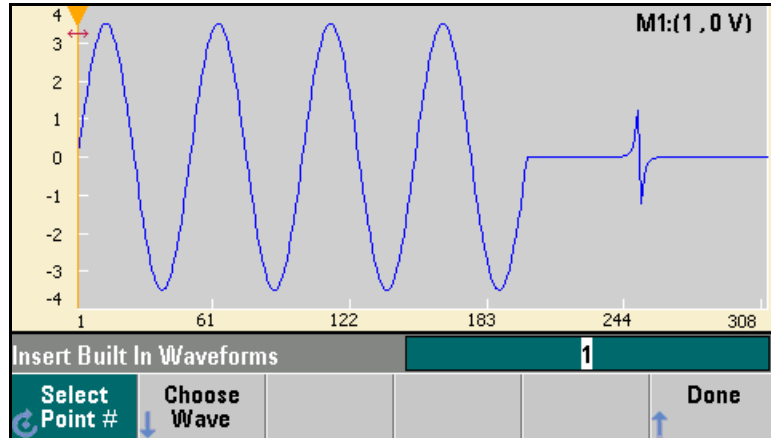

- 7 Notice that the first softkey, Select Point # is highlighted. Put the marker on the 270th waveform point by using the numeric keypad to enter the number 270 and pressing Enter.

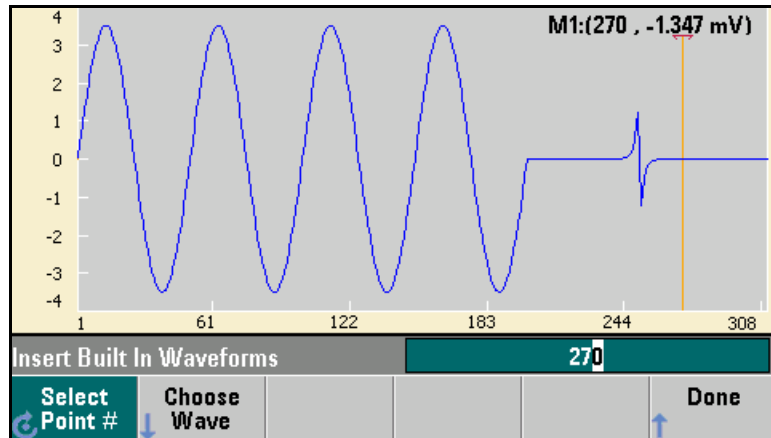

- 8 Press **Choose Wave**, select **Square** and then press **OK**. Set the **Amplitude** to 3 V, the **Offset** to -2 V, the **Cycles** to 8, and the **Points** to 100. Press **OK**. Notice that the 8 square wave cycles have been inserted, beginning at the marker. Press **Done**.

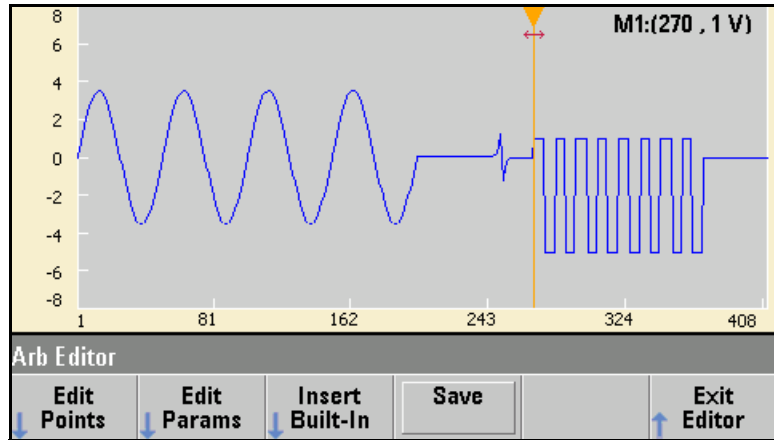

Edit Waveform Characteristics

- 1 Press **Edit Params** and then set the **Sampling Rate** to 100 Sa/s. Press **Cycle Period** and notice that it has been set to 4.08 seconds. This is because you have 408 sample points in the waveform, and the sample rate is 100 Sa/s.

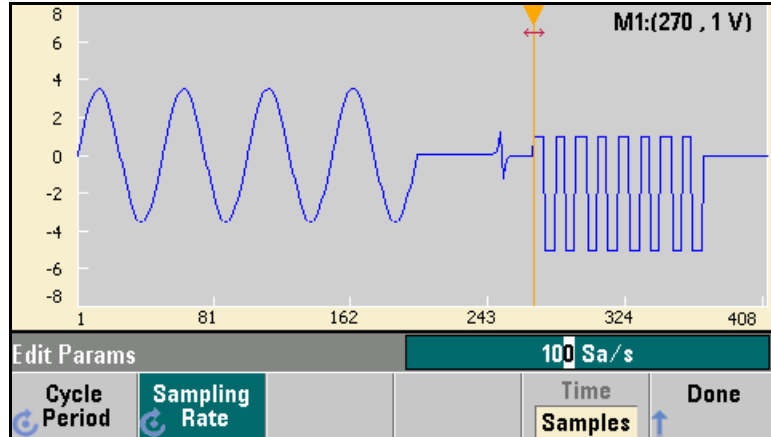

- 2 Change the **Cycle Period** to 2.04 seconds and then press the **Sampling Rate** softkey. It will now be set to 200 Sa/s in order to play the 408 point waveform in 2.04 seconds.

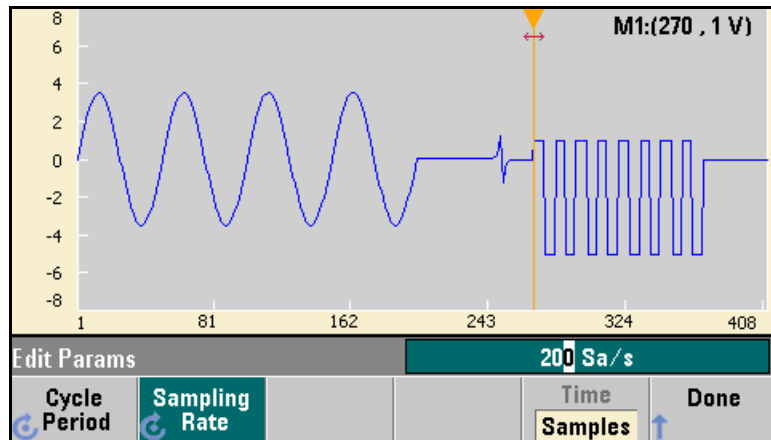

- 3 Press **Done** to exit the parameter editing screen. Press **Edit Points** and notice that the **Point #** softkey is highlighted. Enter the number 160 and press **Enter** to move the marker.

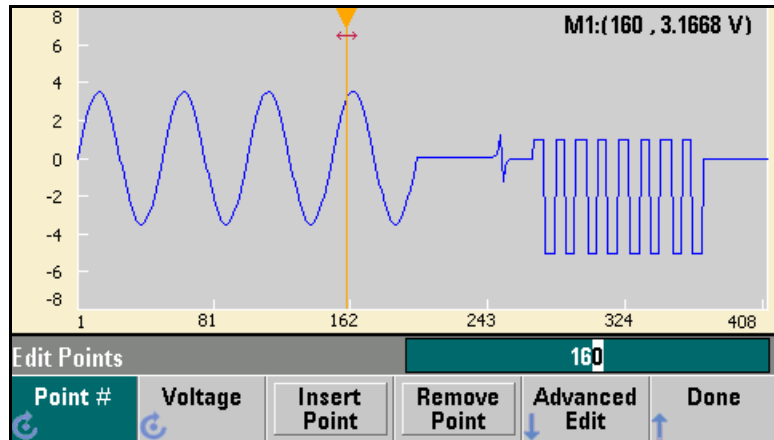

- 4 Press **Voltage** and change the voltage of the selected point to 4.2 V. Press **Point #** and change the point marker to 150 to move the marker off the point. When you press **Enter** to finish entering point 150, you will see the 4.2 V anomaly in the wave that you just created at point 160.

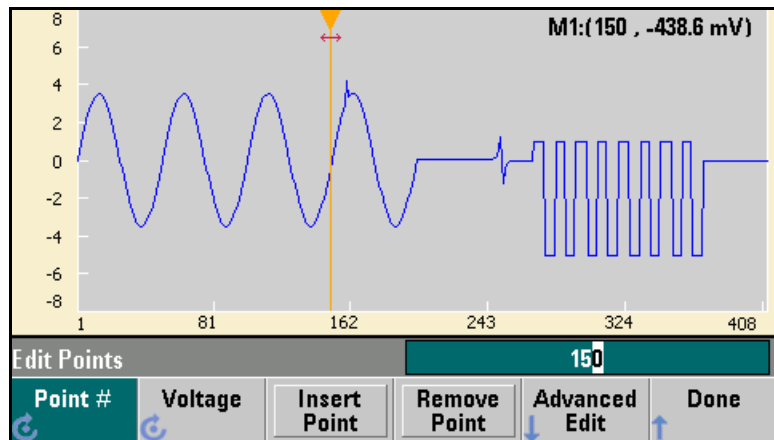

Zoom and Pan

- 1 To see the point in detail, press **System**, then **Pan/Zoom Control**. Notice that the first softkey is set to **Horizontal**, meaning that the zooming that we are about to do will be along the horizontal (time) axis. Change the **Zoom** to **500%**, and the sine wave anomaly will be more obvious.

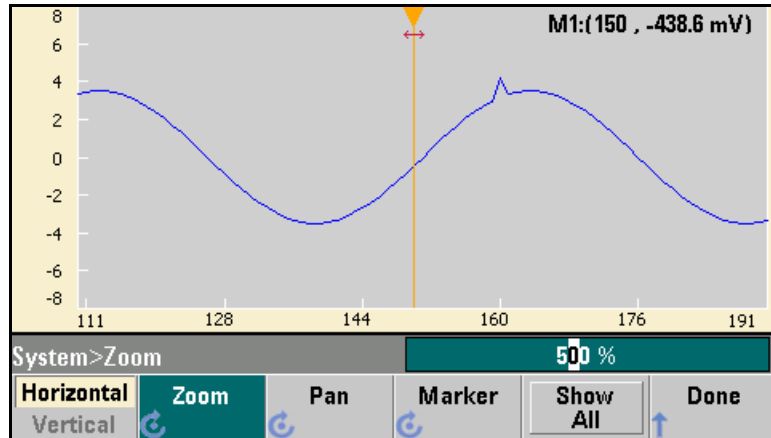

- 2 Now set the first softkey to **Vertical** to zoom vertically. Set the **Zoom** to **500%**. Notice that we have zoomed in on the voltage axis, but we are too low to see the 4.2 V anomaly in the sine wave.

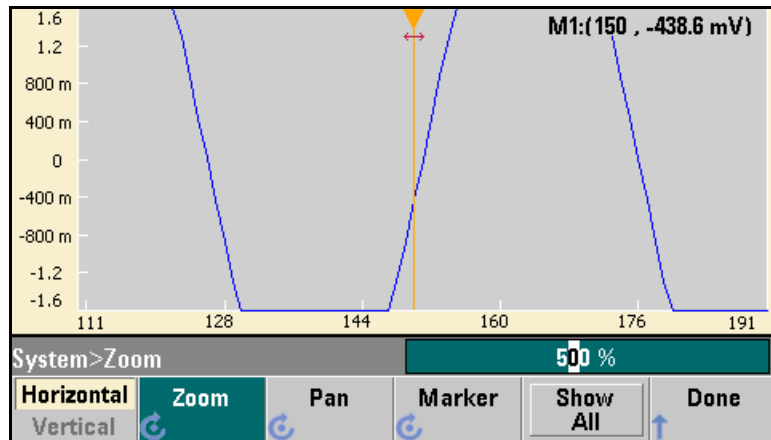

- 3 Press **Pan** and set the **Pan** to 3 V in order to move higher on the waveform. The 4.2 V point is now clearly visible.

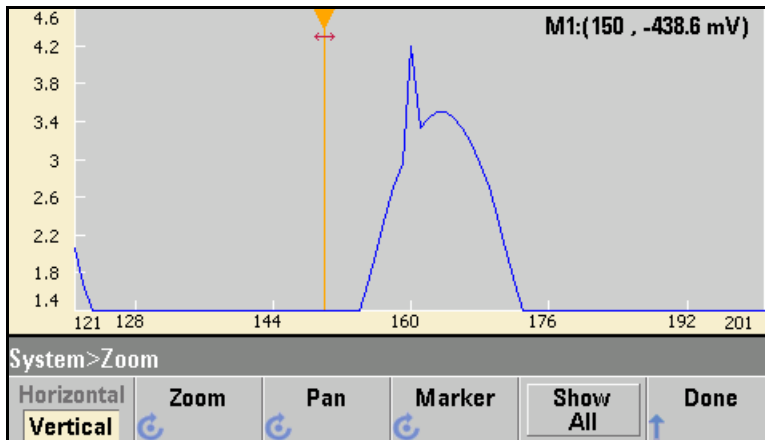

- 4 To see the entire waveform again, press **Show All**. Then press **Done** and **Done** again to return to the **Edit Points** screen.

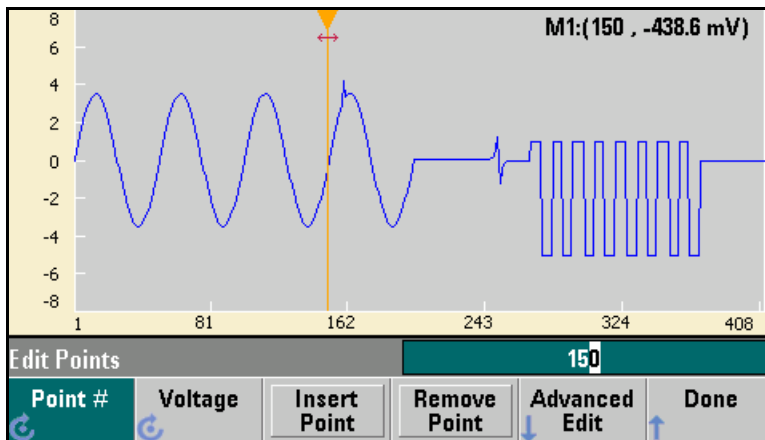

Insert, Remove, Copy and Paste Points

- 1 Press **Insert Point** 15 times and watch the display carefully. You will see 15 new waveform points at the same voltage level.

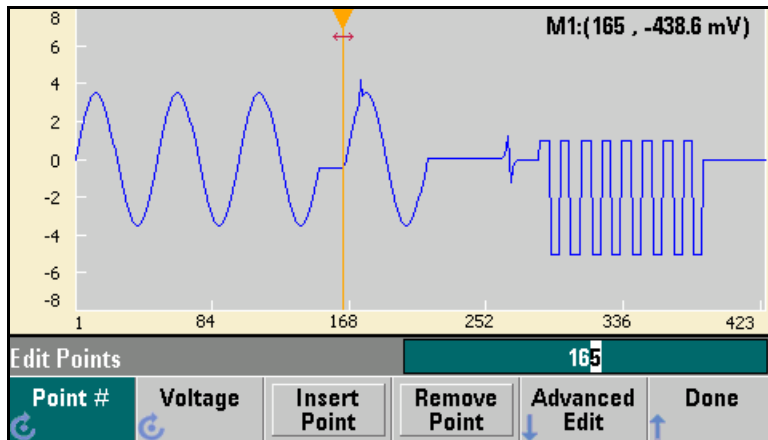

- 2 Change the **Point #** to 220 and press **Remove Point** 20 times, watching the display carefully as you do so in order to see the points being removed from the waveform.

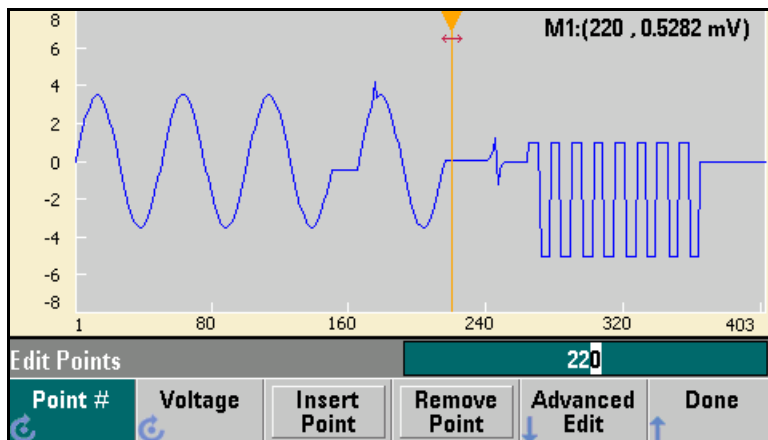

- 3 You can also edit points by using a table of voltages. Press **Advanced Edit** and then **Edit Via Table**. Set **Point #** to 200, and then set the **Voltage** for point 200 to 3 V. Use the knob to move between rows and set the **Voltage** for points 205 and 210 to 3 V. Press **Done**.

Point No. (Max 403)	Voltage Value (Volts)
203	-3.49309
204	-3.49309
205	3.00000
206	-3.32870
207	-3.16690
208	-2.95515
209	-2.69680
210	3.00000

Edit Points>Table 210

Point # Voltage Insert Point Remove Point Done

- 4 Notice the three 3 V spikes that you just made in the waveform at points 200, 205, and 210.

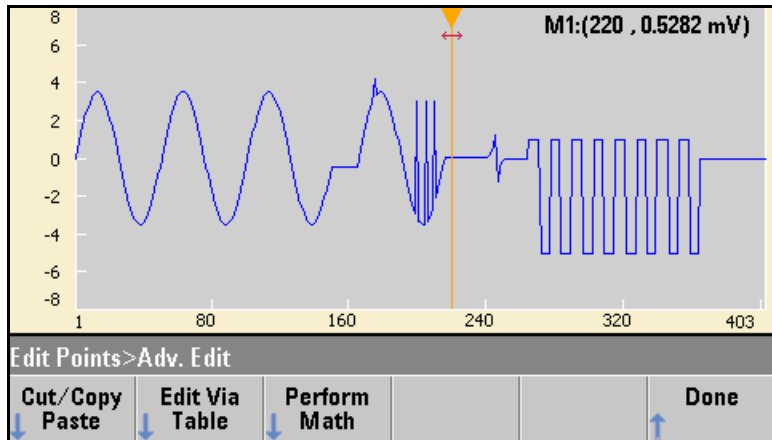

- 5 Press **Cut/Copy Paste**, and set **Marker 1** to 150. Then press the first softkey and change the **Marker** to **Marker 2**. Set **Marker 2** to 300. The range defined by the markers is now highlighted in black.

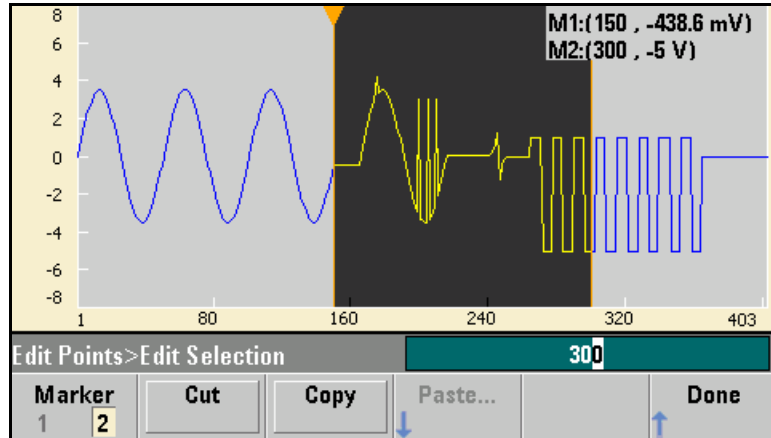

- 6 Press **Copy**, then **Paste**, and then **At Start**. Notice that section you copied is now duplicated at the beginning of the waveform.

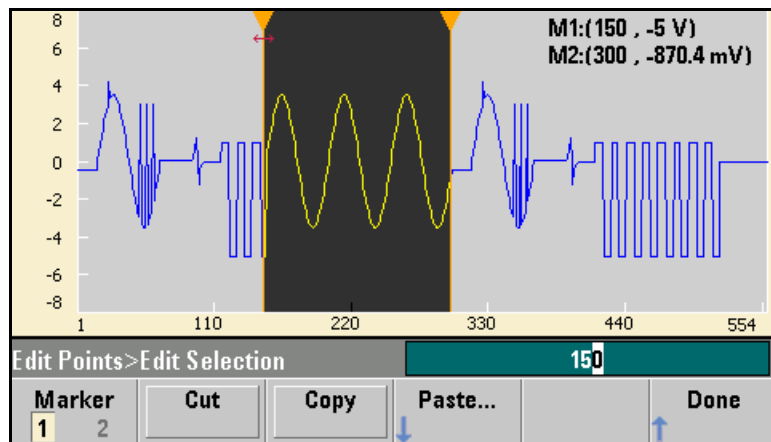

7 Now press **Paste** and **At End**. The same section of the waveform now also appears at the very end.

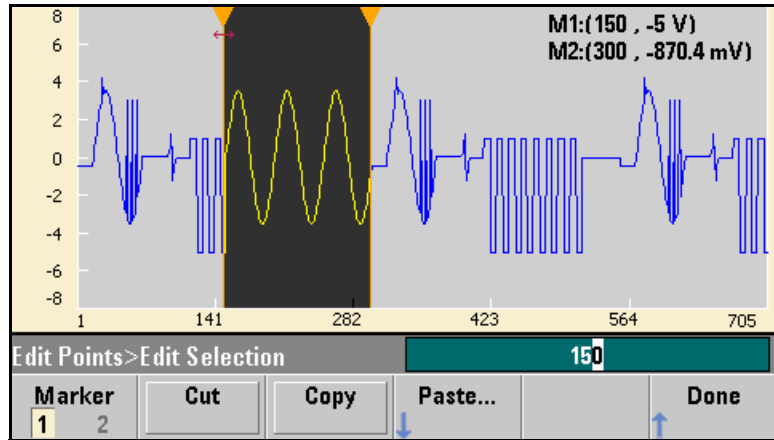

8 Now press **Paste** and change the **Point #** to 500. Then press **OK**, and the same portion of the waveform will be pasted in at point 500. Press **Done** to leave the **Cut/Copy Paste** menu

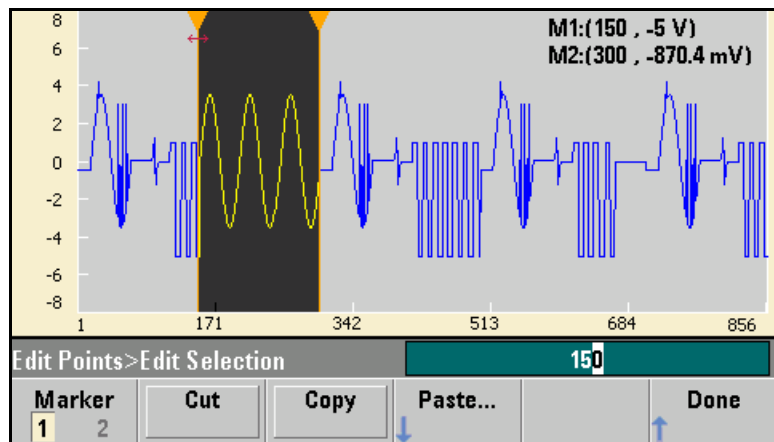

Perform Math

The embedded waveform editor allows you to perform mathematical operations on the waveform. First you set markers to define the range of the waveform that you want to modify. You can then add, subtract or multiply that portion of the waveform by another waveform, or you can transform the waveform in ways that do not involve other waveforms.

- 1 Press **Perform Math**. Set **Marker 1** to 400 and **Marker 2** to 500.

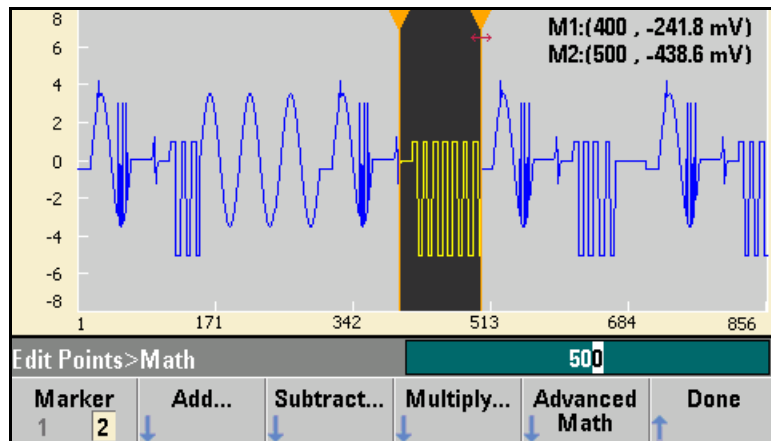

2 Press **Add**, then select **Haversine** and **OK**. Set the **Amplitude** to **3V**, the **Offset** to **0 V**, and press **OK**. Notice that the highlighted section now rises in the middle as a result of the haversine addition.

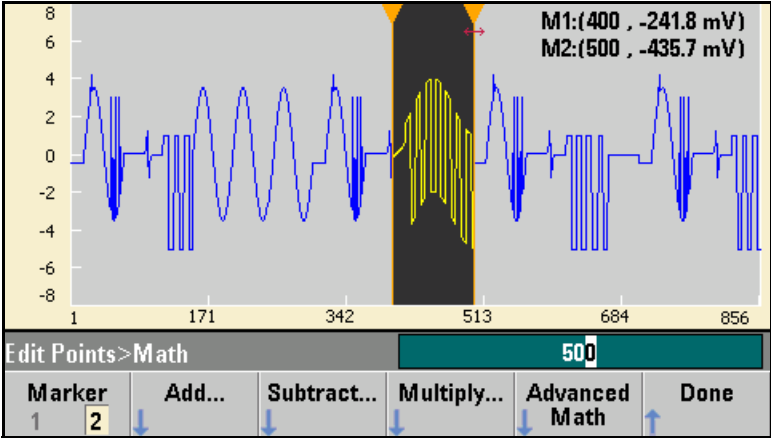

3 Now press **Multiply** and select the **Sine** wave (press **OK**). Set the **Cycles** to **2** and press **OK**.

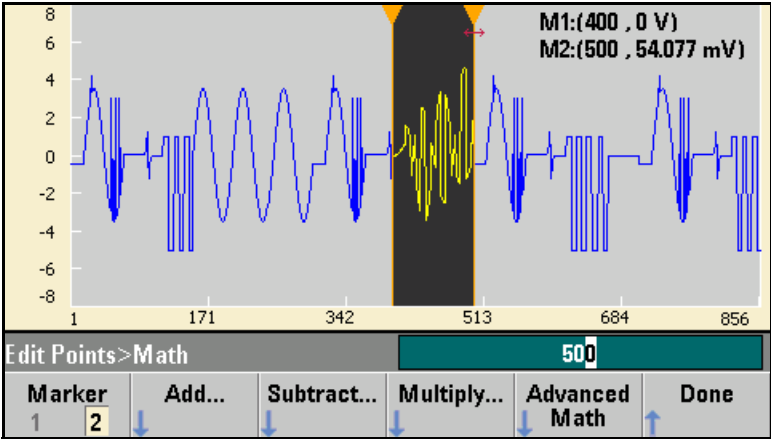

4 Now set **Marker 1** to 200 and **Marker 2** to 600.

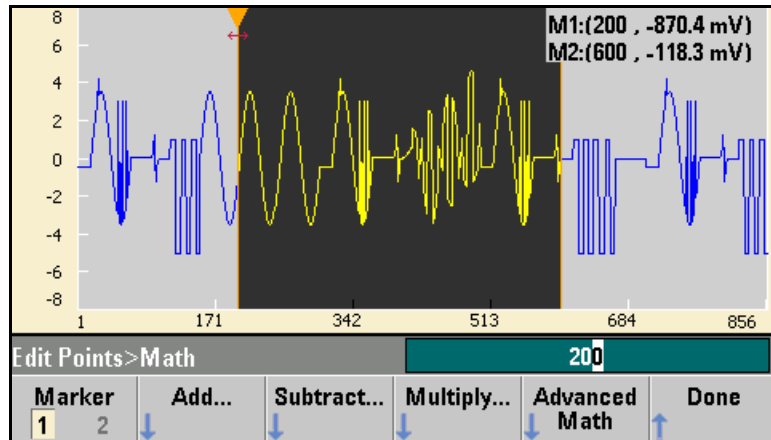

5 Press **Advanced Math**, select **Mirror** and then **OK**

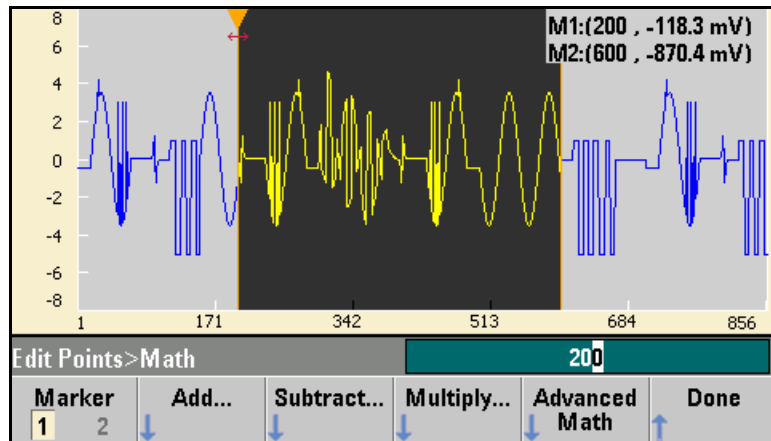

6 Continue learning about the interface by trying other **Advanced Math** features, such as **Invert**, **Absolute**, **Scale**, and so on. Press the **Operation Help** for details on these features.

Features and Functions

Features and Functions

This chapter makes it easy to look up details about a particular feature of the waveform generator. It covers both front panel and remote interface operation. You may want to read chapter 2, “Front-Panel Menu Operation” first. See chapter 4, “Remote Interface Reference” for a detailed discussion of the syntax of the SCPI commands to program the waveform generator. This chapter is divided into the following sections:

- Output Configuration, *on page 92*
- Pulse Waveforms, *on page 110*
- Amplitude Modulation (AM), *on page 114*
- Frequency Modulation (FM), *on page 119*
- Phase Modulation (PM), *on page 125*
- Frequency-Shift Keying (FSK) Modulation, *on page 130*
- Pulse Width Modulation (PWM), *on page 134*
- Frequency Sweep, *on page 143*
- Burst Mode, *on page 152*
- Triggering, *on page 161*
- System-Related Operations, *on page 167*
- Remote Interface Configuration, *on page 178*
- Calibration Overview, *on page 190*
- Factory Default Settings, *on page 215*

Throughout this manual “*default*” states and values are identified. These are the power-on default states *provided* you have not enabled the power-down recall mode (see “Instrument State Storage” on page 167).

Throughout this manual, the following conventions are used for SCPI command syntax for remote interface programming:

- Square brackets ([]) indicate optional keywords or parameters.
- Braces ({ }) enclose parameters within a command string.
- Triangle brackets (< >) enclose parameters for which you must substitute a value.
- A vertical bar (|) separates multiple parameter choices.

Output Configuration

This section contains information to help you configure the waveform generator for outputting waveforms. You may never have to change some of the parameters discussed here, but they are provided to give you flexibility.

Multi-Channel operation:

For waveform generators with two channels, most commands may be preceded by the SCPI “SOURce1:” or “SOURce2:” (abbreviated “SOUR1:” or “SOUR2:”) to explicitly direct the command to a certain channel. If the SOURceN keyword is not used, the default instrument behavior is to direct the command to Channel 1.

For example the command “VOLT 2.5” will set the output voltage on Channel 1 to 2.5 volts. The command “SOUR2:VOLT 1.414” will set the output voltage on channel 2 to 1.414 volts.

Output Function

The waveform generator can output eight standard waveforms: sine, square, ramp, pulse, triangle, gaussian noise, PRBS (pseudo-random binary sequence), and DC. You can also select one of nine built-in arbitrary waveforms or create your own custom waveforms.

The 33500 Series includes an embedded waveform editor. You can use this editor to generate point-by-point arbitrary waveforms, which allows you to create large and complex waveforms.

The table below shows which output functions are allowed with modulation, sweep, and burst. Each “•” indicates a valid combination. If you change to a function that is not allowed with modulation, sweep, or burst, then the modulation or mode is turned off.

Carrier	AM	FM	PM	FSK	BPSK	PWM	Sum	Burst	Sweep
Sine and Square	•	•	•	•	•		•	•	•
Pulse	•	•	•	•	•	•	•	•	•
Triangle and Ramp	•	•	•	•	•		•	•	•
Gaussian Noise	•						•	• ^(a)	
PRBS	•	•	•				•	•	
Single Arb	•		• ^(b)		• ^(b)		•	•	
Sequenced Arb	•						•		





(a) Gated burst only
 (b) Applies to sample clock, not whole waveform

- *Function Limitations:* If you change to a function whose maximum frequency is less than that of the current function, the frequency is adjusted to the maximum value for the new function. For example, if you are currently outputting a 30 MHz sine wave and then change to the ramp function, the waveform generator will automatically adjust the output frequency to 200 kHz (the upper limit for ramps).
- *Amplitude Limitations:* If you change to a function whose maximum amplitude is less than that of the current function, the amplitude is automatically adjusted to the maximum value for the new function. This may occur when the output units are *Vrms* or *dBm* due to the differences in crest factor for the various output functions.





For example, if you output a 5 *Vrms* square wave (into 50 ohms) and then change to the sine wave function, the waveform generator will automatically adjust the output amplitude to 3.536 *Vrms* (the upper limit for sine in *Vrms*).

- The Amplitude and Offset cannot be set such that they combine to exceed the instrument’s capability. Whichever one you set last in this situation will be modified to remain within the instrument’s limits.

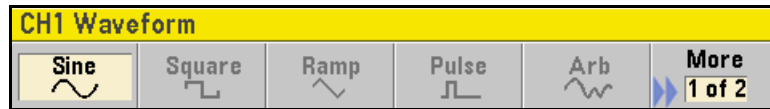

- You may protect a device under test (DUT) by specifying upper and lower voltage limits for the waveform amplitude.
- *Front-Panel Operation:* To select a function, press . Press  (33521A) or  or  (33522A) and then set the **Output** softkey to **ON** to output the currently selected waveform. To view the other waveform choices, press  to see the first page of the list, and then press the **More** softkey to see the rest of the list.



For example, to specify a DC signal from the front panel, press , then **More** and **DC**. Enter the **Offset** with the knob or keypad, and if you use the keypad, press **mV** or **V** to finish entering the value. Then press  or  or  and make sure the **Output** softkey is **ON**.

- *Remote Interface Operation:*

```
FUNction  
{SINusoid|SQUare|RAMP|PULSe|NOISe|DC|PRBS|ARB}
```

You can also use the **APPLY** command to select the function, frequency, amplitude, and offset with a single command.

Output Frequency

As shown below, the output frequency range depends on the function currently selected. *The default frequency is 1 kHz for all functions.*

Function	Minimum Frequency	Maximum Frequency
Sine	1 μ Hz	30 MHz
Square	1 μ Hz	30 MHz
Ramp/Tri.	1 μ Hz	200 kHz
Pulse	1 μ Hz	30 MHz
PRBS	1 μ bps	50 Mbps
Arb	1 μ Sa/s	250 MSa/s

- *Function Limitations:* If you change to a function whose maximum frequency is less than that of the current function, the frequency is adjusted to the maximum value for the new function. For example, if you are currently outputting a 20 MHz sine wave and then change to the ramp function, the waveform generator will automatically adjust the output frequency to 200 kHz (the upper limit for ramps and triangles).
- *Burst Limitation:* For internally-triggered bursts, the minimum frequency is 126 μ Hz.
- *Duty Cycle Limitations:* For Square and Pulse, Duty Cycle is limited by the 16-ns minimum pulse width specification. For example, at 1 kHz, Duty Cycle may be adjusted as low as 0.01% because that would result in a pulse width of 100 ns. However, at 1 MHz the minimum Duty Cycle is 1.6%, and at 10 MHz it's 16%. At 30 MHz, Duty Cycle may only be adjusted from 48% to 52%.

If you change to a frequency that cannot produce the current duty cycle, the duty cycle is automatically adjusted in order to meet the minimum pulse width specification.

Output Configuration

- *Front-Panel Operation:* To set the output frequency, press the **Parameters** button, then the **Frequency** softkey for the selected function. Then use the knob or numeric keypad to enter the desired frequency. To set the waveform period instead, press **Units** and then press the **Frequency** softkey to toggle to the setting to **Period**.
- *Remote Interface Operation:*

```
[SOURce [1 | 2] :] FREQUency {<frequency> | MINimum | MAXimum}
```

You can also use the **APPLY** command to select the function, frequency, amplitude, and offset with a single command.







Output Amplitude

The default amplitude is 100 mVpp (into 50 ohms) for all functions.

- *Offset Voltage Limitations:* The relationship between output amplitude and offset voltage is shown below. V_{max} is the maximum *peak voltage* for the selected output termination (± 5 volts for a 50 Ω load or ± 10 volts for a high-impedance load).

$$V_{pp} \leq 2(V_{max} - |V_{offset}|)$$

- *Limits Due to Output Termination:* If you change the output termination setting, the displayed output amplitude will be adjusted to reflect the new setting, but the actual amplitude of the output signal will not be changed. For example, if you set the amplitude to 10 Vpp and then change the output termination from 50 ohms to “high impedance”, the amplitude displayed on the waveform generator’s front-panel will *double* to 20 Vpp. If you change from “high impedance” to 50 ohms, the displayed amplitude will drop in half. *For more information, see “Output Termination” on page 101.*
- *Limits Due to Units Selection:* In some cases, the amplitude limits are determined by the output units selected. This might occur when the units are *Vrms* or *dBm* due to the differences in crest factor for the various output functions. For example, if you output a 5 Vrms square wave (into 50 ohms) and then change to the sine wave function, the waveform generator will automatically adjust the output amplitude to 3.536 Vrms (the upper limit for sine waves in Vrms).

- You can set the output amplitude in Vpp, Vrms, or dBm. *For more information, see “Output Units” on page 100.*
- You cannot specify the output amplitude in dBm if the output termination is currently set to “high impedance”. The units are automatically converted to Vpp. *For more information, see “Output Units” on page 100.*
- *Arbitrary Waveform Limitations:* For arbitrary waveforms, the maximum amplitude will be limited if the waveform data points do not span the full range of the output DAC (Digital-to-Analog Converter). For example, the built-in “Sinc” waveform does not use the full range of values between ± 1 and therefore its maximum amplitude is limited to 6.087 Vpp (into 50 ohms).
- While changing amplitude, you may notice a momentary disruption in the output waveform at certain voltages due to switching of the output attenuators. To prevent this disruption in the output, you can disable the voltage autoranging feature as described on page 105.
- You can also set the amplitude and offset voltage by specifying a high level and low level. For example, if you set the high level to +2 volts and the low level to -3 volts, the resulting amplitude is 5 Vpp (with an offset voltage of -500 mV).
- For a DC signal, the output level is actually controlled by setting the offset voltage. You can set the DC level to any value between -5 V and +5 V with a 50 Ω load or -10 to +10 VDC with a high-impedance load. *See “DC Offset Voltage” on the following page for more information.*
- To select a DC signal from the front panel, press , then **More** and **DC**. Enter the **Offset** with the knob or keypad, and if you use the keypad, press **mV** or **V** to finish entering the value. Then press  or  or  and make sure the **Output** softkey is **ON**.
- *Front-Panel Operation:* To set the output amplitude, press  and then the **Amplitude** softkey for the selected function. Then use the knob or numeric keypad to enter the desired amplitude. To set the amplitude using a high level and low level, press  and then press the **Amp/Offs** softkey to toggle it to **High/Low**.

- *Remote Interface Operation:*

```
VOLTage {<amplitude>|MINimum|MAXimum}
```

Or, you can set the amplitude by specifying a high level and low level using the following commands.

```
VOLTage:HIGH {<voltage>|MINimum|MAXimum}  
VOLTage:LOW {<voltage>|MINimum|MAXimum}
```

You can also use the APPLy command to select the function, frequency, amplitude, and offset with a single command.

DC Offset Voltage

The default offset is 0 volts for all functions.





- *Limits Due to Amplitude:* The relationship between offset voltage and output amplitude is shown below. The peak output voltage (DC plus AC) cannot exceed the instrument output rating (± 5 V into 50Ω load, or ± 10 V into a high impedance load).
- V_{max} is the maximum peak voltage for the selected output termination (± 5 V for a 50Ω load or ± 10 V for a high-impedance load).

$$|V_{offset}| < V_{max} - V_{pp}/2$$

If the specified offset voltage is not valid, the waveform generator will automatically adjust it to the maximum DC voltage allowed with the amplitude specified.

- *Limits Due to Output Termination:* The offset limits are determined by the current output termination setting. For example, if you set the offset to 100 mVDC and then change the output termination from 50 ohms to high impedance, the offset voltage displayed on the waveform generator's front-panel will *double* to 200 mVDC (and no error will be generated). If you change from high impedance to 50 ohms, the displayed offset will drop in half. *See "Output Termination" on page 101 for more information.*

- *Arbitrary Waveform Limitations:* For arbitrary waveforms, the maximum offset and amplitude will be limited if the waveform data points do not span the full range of the output DAC (Digital-to-Analog Converter).
- You can also set the offset by specifying a high level and low level. For example, if you set the high level to +2 volts and the low level to -3 volts, the resulting amplitude is 5 Vpp (with an offset voltage of -500 mV).
- For the DC volts function, you control the output level by setting the offset voltage. You can set the DC level to any value between ± 5 VDC into 50 ohms or ± 10 VDC into an open circuit.

Front-Panel Operation: To select a DC signal from the front panel, press , then **More** and **DC**. Enter the **Offset** with the knob or keypad, and if you use the keypad, press **mV** or **V** to finish entering the value. Then press  or  or  and make sure the **Output** softkey is **ON**.

- *Remote Interface Operation:*

```
[SOURCE [1 | 2] :] VOLTage:OFFSet
{ <offset> | MINimum | MAXimum }
```

Or, you can set the offset by specifying a high level and low level using the following commands.

```
[SOURCE [1 | 2] :] VOLTage:HIGH
{ <voltage> | MINimum | MAXimum }
[SOURCE [1 | 2] :] VOLTage:LOW
{ <voltage> | MINimum | MAXimum }
```

You can also use the **APPLY** command to select the function, frequency, amplitude, and offset with a single command.

Output Units

Applies to output amplitude only. At power-on, the units for output amplitude are volts peak-to-peak.

- Output units: Vpp (default), Vrms, or dBm.
- The unit setting is stored in *volatile* memory. The units are set to “Vpp” when power has been off or after a remote interface reset (provided the Power On state is set to Factory).
- The waveform generator uses the current units selection for both front panel and remote interface operations. For example, if you select “VRMS” from the remote interface, the units are displayed as “VRMS” on the front panel.
- The output units for amplitude cannot be set to dBm if the output termination is currently set to “high impedance”. This is because calculating dBm requires a finite load impedance. In this case, the units are automatically converted to Vpp.
- *Front-Panel Operation:* Use the numeric keypad to enter the desired magnitude and then press the appropriate softkey to select the units. You can also convert from one unit to another from the front panel. For example, to convert 2 Vpp to its equivalent value in Vrms, press and then press the **Ampl As** softkey, then the **Vrms** softkey. The converted value is 707.1 mVrms for a sine wave.
- *Remote Interface Operation:*

```
VOLTage:UNIT {VPP|VRMS|DBM}
```

Output Termination

Applies to output amplitude and offset voltage only. The 33500 Series has a fixed series output impedance of 50 ohms to the front-panel channel output connectors. If the actual load impedance is different than the value specified, the displayed amplitude and offset levels will not reflect actual voltages at the load.

- Output termination: 1 Ω to 10 k Ω , or infinite. The default is 50 Ω . The tab at the top of each channel indicates the value of this setting.

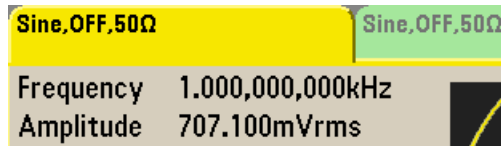

- If you specify a 50-ohm termination but are actually terminating into an open circuit, the actual output will be *twice* the value specified. For example, if you set the DC offset to 100 mVDC (and specify a 50 Ω load) but are terminating the output into an open circuit, the actual offset will be 200 mVDC.
- If you change the output termination setting, the displayed output amplitude and offset levels are automatically adjusted (no error will be generated). For example, if you set the amplitude to 10 Vpp and then change the output termination from 50 ohms to high impedance, the amplitude displayed on the waveform generator's front-panel will *double* to 20 Vpp. If you change from "high impedance" to 50 ohms, the displayed amplitude and offset will drop in half. This changes the displayed value, not the generated output voltage.
- You cannot specify the output amplitude in dBm if the output termination is currently set to high impedance. The units are automatically converted to Vpp.
- You cannot change the output termination if voltage limits are enabled, because the instrument cannot know which output termination settings the voltage limits apply to. To change output termination, disable voltage limits, set the new termination value, adjust the voltage limits, and re-enable voltage limits.

Output Configuration

- *Front-Panel Operation:* Press **Channel** or **1** or **2** and select the **Output Load** softkey. Then press **Set To 50 Ω**, **Set To High Z**, or **Load**. If you select **Load**, use the knob or numeric keypad to select the impedance.
- *Remote Interface Operation:*

```
OUTPut [1|2]:LOAD {<ohms>|INFinity|MINimum|MAXimum}
```

Duty Cycle (Square Waves)

The duty cycle of a square wave represents the fraction of time per cycle that the square wave is at a *high level* (assuming that the waveform is not inverted).

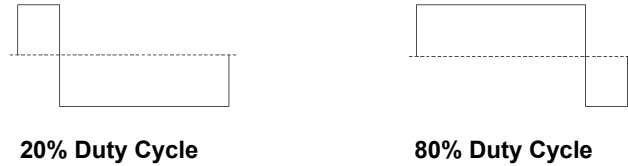

(See Pulse Waveforms, on page 110 for information about duty cycle for pulse waveforms.)

- Duty Cycle: 0.01% to 99.99% , at low frequencies; range is reduced at higher output frequency.
- The duty cycle is stored in *volatile* memory; the default value is 50%.
- The duty cycle setting is remembered when you change from square wave to another function. The duty cycle setting *does not* apply to a square waveform used as the *modulating* waveform for AM, FM, PM or PWM. A 50% duty cycle is always used for a modulating square waveform. The duty cycle setting applies only to a square waveform *carrier*.
- *Front-Panel Operation:* After selecting the square wave function, press the **Duty Cycle** softkey. Then use the knob or numeric keypad to enter the desired duty cycle. If you use the numeric keypad, press **Percent** to complete the entry.
- *Remote Interface Operation:*

```
FUNCTION:SQUare:DCYCLE {<percent>|MINimum|MAXimum}
```

The APPLY command automatically sets the duty cycle to 50%.

Symmetry (Ramp Waves)

Applies to ramp waves only. Symmetry represents the fraction of each cycle that the ramp wave is *rising* (assuming that the waveform is not inverted).

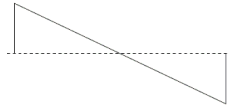

0% Symmetry

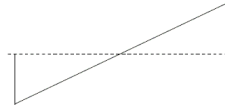

100% Symmetry

- The symmetry is stored in *volatile* memory; the default value is 100%.
- The symmetry setting is remembered when you change from ramp to another waveform. When you return to the ramp waveform, the previous symmetry value is used.
- If you select a ramp waveform as the *modulating* waveform for AM, FM, PM, or PWM, the symmetry setting *does not* apply.
- *Front-Panel Operation:* After selecting the ramp function, press the **Symmetry** softkey. Then press the **100%**, **50%**, or **0%** softkey or press **Symmetry** and use the knob or numeric keypad to enter the desired symmetry. If you use the numeric keypad, press **Percent** to complete the entry.
- *Remote Interface Operation:*

```
FUNCTION:RAMP:SYMMetry {<percent>|MINimum|MAXimum}
```

The **APPLY** command automatically sets the symmetry to 100%.

Voltage Autoranging

Autoranging is enabled by default and the waveform generator automatically selects the optimal settings for the attenuators. With autoranging disabled, the waveform generator uses the current attenuator settings and does not switch attenuator relays.

- You can disable autoranging to eliminate momentary disruptions caused by switching of the attenuators while changing amplitude. *However, turning autoranging off has side effects:*
 - The amplitude and offset accuracy and resolution (and waveform fidelity) may be adversely affected when reducing the amplitude below a range change that would occur with autoranging on.
 - You may not be able to achieve the minimum amplitude that is available with autoranging on.
 - Some instrument specifications do not apply with autoranging off.
- *Front-Panel Operation:* Press **Channel** or **1** or **2** and press the **Range** softkey again to toggle between the **Auto** and **Hold** selections.
- *Remote Interface Operation:*

```
VOLTage:RANGe:AUTO {OFF|ON|ONCE}
```

The **APPLY** command overrides the voltage autorange setting and automatically enables autoranging.

Output Control

You can disable or enable the front-panel channel output connector. By default, the output is disabled at power on to protect other equipment. When a channel output connector is enabled, the corresponding **Channel** or **1** or **2** key is illuminated.

- *Front-Panel Operation:* Press **Channel** or **1** or **2** followed by **Output On/Off** to enable the output.
- If an excessive external voltage is applied to a front-panel channel output connector by an external circuit, the instrument will generate an error message and disable the output. To re-enable the output, remove the overload from the connector and press **Channel** or **1** or **2** followed by **Output On/Off** to enable the output.

- *Remote Interface Operation:*

```
OUTPut [1|2] {OFF|ON}
```

The APPLy command overrides the current setting and automatically enables the channel output connector.

Waveform Polarity

In the *normal* mode (default), the waveform goes positive during the first part of the cycle. In the *inverted* mode, the waveform goes negative during the first part of the cycle.

- As shown in the examples below, the waveform is inverted *relative to* the offset voltage. Any offset voltage present will remain unchanged when the waveform is inverted.

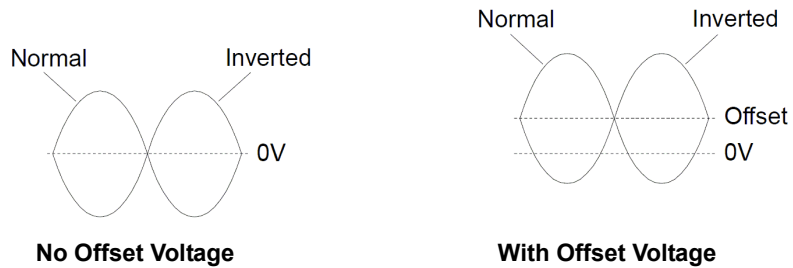

- When a waveform is inverted, the Sync signal associated with the waveform *is not* inverted.
- *Front-Panel Operation:* Press **Channel** or **1** or **2** and then press **Polarity** to toggle between the **Normal** and **Inverted** selections.
- *Remote Interface Operation:*

```
OUTPut [1|2]:POLarity {NORMal|INVerted}
```

Sync Output Signal

A sync output is provided on the front-panel *Sync* connector. All of the standard output functions (except DC and noise) have an associated Sync signal. For applications where you may not want to output the Sync signal, you can disable the *Sync* connector. The Sync signal may be derived from either output channel in a two-channel instrument.

- By default the Sync signal is derived from Channel 1.
- By default, the Sync signal is routed to the *Sync* connector (enabled).
- When the Sync signal is disabled, the output level on the *Sync* connector is at a logic “low” level.
- When a waveform is inverted (see “Waveform Polarity” on the previous page), the Sync signal associated with the waveform *is not* inverted.
- The Sync signal setting is overridden by the setting of the marker used with the sweep mode (see page 148). Therefore, when the marker is enabled (and the sweep mode is also enabled), the Sync signal setting is ignored.
- For sine, pulse, ramp, square, and triangle waveforms, the Sync signal is a square waveform with a 50% duty cycle. The Sync signal is “high” in the first half of the cycle and “low” in the last half. The Sync signal’s voltage levels are TTL-compatible when its load impedance is more than 1 k Ω .
- For arbitrary waveforms, the Sync signal is a Marker pulse with a rising edge at the beginning of the ARB waveform, and a falling edge at the point number selected as Marker. The Sync signal is a TTL “high” when the first downloaded waveform point is output. This default behavior may be overridden by using the MARKer:POINT command which specifies a certain point within the arbitrary waveform at which the Sync signal will transition to “low”.

Output Configuration

- For internally-modulated *AM*, *FM*, *PM*, and *PWM*, the Sync signal is normally referenced to the modulating waveform (not the carrier) and is a square waveform with a 50% duty cycle. The Sync signal is a TTL “high” during the first half of the modulating waveform. You can set up the Sync signal to follow the carrier waveform by using the command:

```
OUTPut:SYNC:MODE {CARRier | NORMAl}
```

when modulating with internal modulation.

- For externally-modulated *AM*, *FM*, *PM*, and *PWM*, the Sync signal is referenced to the carrier waveform (not the modulating waveform) and is a square waveform with a 50% duty cycle.
- The polarity of the Sync signal may be inverted using the SCPI command:

```
OUTPut:SYNC:POLarity {INVerted | NORMAl}
```

- For *FSK*, the Sync signal is referenced to the “hop” frequency. The Sync signal is a TTL “high” on the transition to the “hop” frequency.
- For *frequency sweeps* with *Marker Off*, the Sync signal is a square waveform with a 50% duty cycle for the duration of the sweep. The Sync signal is a TTL “high” at the beginning of the sweep and goes “low” at the midpoint of the sweep. The Sync signal is synchronized with the sweep, but is not equal to the sweep time because its timing includes the re-arm time.
- For *frequency sweeps* with *Marker On*, the Sync signal is a TTL “high” at the beginning of the sweep and goes “low” at the marker frequency. You can change this behavior with the `OUTPut [1 | 2] : SYNC : MODE` command.
- You can override normal sync behavior to force Sync to always follow the carrier waveform. The command for doing this is called `OUTPut [1 | 2] : SYNC : MODE`; see the *Agilent 33500 Series Programmer’s Reference Help* for details.

- For a *triggered burst*, the Sync signal is a TTL “high” when the burst begins. The Sync signal is a TTL “low” at the end of the specified number of cycles (may not be the zero-crossing point if the waveform has an associated start phase). For an *infinite count burst*, the Sync signal is the same as for a continuous waveform.
- For an *externally-gated burst*, the Sync signal follows the external gate signal. However, the signal will not go to a TTL “low” until the end of the last cycle (may not be the zero-crossing point if the waveform has an associated start phase).
- *Front-Panel Operation:* Press  and press the **Sync** softkey again to toggle between **Off** and **On**. You can also press **Sync Setup** to configure Sync.
- *Remote Interface Operation:*

```
OUTPut:SYNC {OFF|ON}  
OUTPUT[1|2]:SYNC:MODE {CARRier|NORMal|MARKer}  
OUTPUT[1|2]:SYNC:POLARITY {NORMAl|INVerted}  
OUTPUT:SYNC:SOURCE {CH1|CH2}
```

Pulse Waveforms

As shown below, a pulse or square waveform consists of a *period*, a *pulse width*, a *rising edge*, and a *falling edge*.

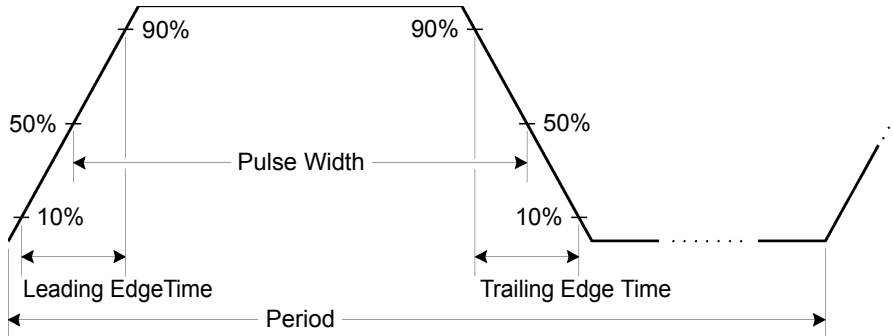

Period

- Period: 33.3 ns to 1,000,000 s. *The default is 1 ms.* Period is the reciprocal of frequency.
- The waveform generator will adjust the pulse width and edge time as needed to accommodate the specified period.
- *Front-Panel Operation:* After selecting the pulse function, press **Units**, then the **Frequency/Period** softkey to toggle to **Period**. Then press **Parameters**, then **Period**. Use the knob or numeric keypad to enter the desired pulse period.
- *Remote Interface Operation:*

```
[SOURCE[1|2]:]FUNCTION:PULSe:PERiod  
  {<seconds>|MINimum|MAXimum}
```

Pulse Width

The pulse width represents the time from the 50% threshold of the rising edge of the pulse to the 50% threshold of the next falling edge.

- Pulse width: 16 ns to 1,000,000 s (see restrictions below). *The default pulse width is 100 μs.*
- The specified pulse width must also be less than the difference between the *period* and the *minimum pulse width as shown below*. The waveform generator will adjust the pulse width as needed to accommodate the specified period.

$$\text{Pulse Width} \leq \text{Period} - 16 \text{ ns}$$

- The waveform generator will automatically adjust the pulse width as needed to accommodate the specified period.
- *Front-Panel Operation:* After selecting the pulse function, press the **Pulse Width** softkey. Then use the knob or numeric keypad to enter the desired pulse width.
- *Remote Interface Operation:*

```
FUNCTION:PULSe:WIDTh {<seconds>|MINimum|MAXimum}
```

Pulse Duty Cycle

The pulse duty cycle is defined as:

$$\text{Duty Cycle} = 100(\text{Pulse Width})/\text{Period}$$



where the pulse width represents the time from the 50% threshold of the rising edge of the pulse to the 50% threshold of the next falling edge.

- Pulse duty cycle: 0% to 100% (see restrictions below). The default is 10%.
- The specified pulse duty cycle must conform to the following restrictions determined by the *minimum pulse width* (W_{\min}). The waveform generator will adjust the pulse duty cycle as needed to accommodate the specified period.

$$\text{Duty Cycle} \geq 100(16 \text{ ns}) / \text{Period}$$

and

$$\text{Duty Cycle} \leq 100(1 - 16 \text{ ns} / \text{Period})$$

- The specified pulse duty cycle must conform to the following restriction determined by the *edge time*. The waveform generator will adjust the pulse duty cycle as needed to accommodate the specified period.
- To achieve edges > 8.4 ns, the pulse width must be at least 20 ns. The longer the edges, the greater the minimum pulse width. Longer edges will therefore restrict duty cycle more than shorter edges.
- *Front-Panel Operation:* After selecting the pulse function, press  and toggle the **Width/Duty Cyc** softkey to the **Duty Cyc** softkey. Then press , followed by **Duty Cycle**, and use the knob or numeric keypad to enter the desired duty cycle.
- *Remote Interface Operation:*

```
FUNCTION:PULSE:DCYCLE {<percent>|MINimum|MAXimum}
```

Edge Times

The edge times set the transition times for the leading and trailing edges of the pulse, either independently or together. For each transition (leading or trailing edge), the edge time represents the time between the 10% and 90% thresholds.

- Edge time: 8.4 ns to 1 μ s (see restrictions below). *The default edge time is 10 ns.*
- The specified edge time must fit within the specified pulse width as shown below. The waveform generator will adjust the edge time as needed to accommodate the specified pulse width.
- *Front-Panel Operation:* After selecting the pulse function, press the **Edge Times** softkey. Then use the **Lead Edge** and **Trail Edge** softkeys, followed by the knob or numeric keypad to enter the desired edge times.
- *Remote Interface Operation:*

```
FUNCTION:PULSe:TRANSition:LEADing  
  { <seconds> | MINimum | MAXimum }
```

```
FUNCTION:PULSe:TRANSition:TRAILing  
  { <seconds> | MINimum | MAXimum }
```

```
FUNCTION:PULSe:TRANSition[:BOTH]  
  { <seconds> | MINimum | MAXimum }
```

Amplitude Modulation (AM)

A modulated waveform consists of a *carrier waveform* and a *modulating waveform*. In AM, the amplitude of the carrier is varied by the instantaneous level of the modulating waveform. The waveform generator will accept an internal or external modulation source. The 33500 Series offers two types of AM: DSFC (Double-Sideband, Full-Carrier, the type normally used for AM radio broadcasting) and DSSC (Double-Sideband, Suppressed Carrier).

For more information on the fundamentals of Amplitude Modulation, refer to chapter 5, “Tutorial.”

To Select AM Modulation

- The 33500 Series will allow only one modulation mode to be enabled at a time on a channel. For example, you cannot simultaneously enable AM and FM. When you enable AM, any previous modulation mode is turned off. The two-channel 33522A can combine the modulated waveforms from two channels together by adding them (see the COMBine command in the *Agilent 33500 Series Programmer’s Reference Help* for details). The modulation on each channel is independent of the modulation on the other channel. See the PHASe:SYNChronize command in the *Agilent 33500 Series Programmer’s Reference Help* for details.
- The waveform generator will not allow AM to be enabled at the same time as sweep or burst. When you enable AM, the sweep or burst mode is turned off.
- *Front-Panel Operation:* You must select AM *before* setting up any of the other modulation parameters. Press **Modulate** and then select **AM** using the **Type** softkey. The AM waveform is output using the present settings for the carrier frequency, modulating frequency, output amplitude, and offset voltage.
- *Remote Interface Operation:* To avoid multiple waveform changes, enable AM *after* you have set up the other modulation parameters.

```
AM:STATe {OFF|ON}
```

Carrier Waveform Shape

- AM carrier shape: Sine (default), Square, Pulse, Ramp, Triangle, Noise, PRBS, or Arbitrary waveform. You *cannot* use DC as the carrier waveform.
- *Front-Panel Operation:* Select any waveform under  except **DC**. For arbitrary waveforms, press **Arb** and **Arbs**, and then choose the **Select Arb** softkey to select the active waveform.
- *Remote Interface Operation:*

```
FUNCTION
{SINusoid|SQUare|PULSe|RAMP|ARB|NOISe|PRBS}
```

You can also use the **APPLY** command to select the function, frequency, amplitude, and offset with a single command.

Carrier Frequency

The maximum carrier frequency depends on the function selected as shown below. *The default is 1 kHz for all functions.* Arbitrary waveform “frequency” is also set using the **FUNCTION:ARBITRARY:SRATE** command.

Function	Minimum Frequency	Maximum Frequency
Sine	1 μ Hz	30 MHz
Square	1 μ Hz	30 MHz
Ramp	1 μ Hz	200 kHz
Pulse	1 μ Hz	30 MHz
PRBS	1 μ Hz	30 MHz
Noise BW	1 mHz	30 MHz
Arbs	1 μ Sa/sec	250 MSa/sec





- *Front-Panel Operation:* To set the carrier frequency, press the  button, then the **Frequency** softkey. Then use the knob or numeric keypad to enter the desired frequency.
- *Remote Interface Operation:*

```
[SOURCE[1|2]:]FREQUENCY {<frequency>|MINimum|MAXimum}
```

You can also use the **APPLY** command to select the function, frequency, amplitude, and offset with a single command.

Modulating Waveform Shape

The waveform generator will accept an internal or external modulation source for AM.

- Modulating waveform shape (*internal source*): Sine (default), Square, UpRamp, DnRamp, Triangle, Noise, PRBS, or Arb waveform.
 - Square has 50% duty cycle 
 - UpRamp has 100% symmetry 
 - Triangle has 50% symmetry 
 - DnRamp has 0% symmetry 
 - Noise - white gaussian noise
 - PRBS - Pseudo Random Bit Sequence (polynomial PN7)
 - Arb - Arbitrary waveform
- *Front-Panel Operation*: After enabling AM, press the **Shape** softkey.
- *Remote Interface Operation*:

```
AM:INTernal:FUNCTion
    {SINusoid|SQUare|PULSe|RAMP|NRAMP|TRIangle|
    NOISe|PRBS|ARB}
```

Modulating Waveform Frequency

The waveform generator will accept an internal or external modulation source for AM.

- Modulating frequency (*internal source*): varies by signal type, from 1 μ Hz to 30 MHz. *The default is 100 Hz.*
- Modulating frequency (*external source*): 0 to 100 kHz
- *Front-Panel Operation*: After enabling AM modulation, press **More** and then the **AM Freq** softkey.

- *Remote Interface Operation:*

```
[SOURCE[1|2]]:AM:INTernal:FREQuency  
{<frequency>|MINimum|MAXimum}
```

Modulation Depth

The *modulation depth* is expressed as a percentage and represents the extent of the amplitude variation. At 0% depth, the output amplitude is constant at one-half of the carrier's amplitude setting. At 100% depth, the output amplitude varies according to the modulating waveform, from 0% to 100% of the carrier's amplitude setting.

- Modulation depth: 0% to 120%. *The default is 100%.*
- Even at greater than 100% depth, the waveform generator will not exceed ± 5 V peak on the output (into a 50 Ω load). To achieve modulation depth greater than 100%, output carrier amplitude may be reduced.
- *Front-Panel Operation:* After enabling AM, press the **AM Depth** softkey. Then use the knob or numeric keypad to enter the depth.
- *Remote Interface Operation:*

```
AM:DEPTh {<depth_in_percent>|MINimum|MAXimum}
```

Double Sideband Suppressed Carrier AM

The 33500 Series supports two forms of amplitude modulation, “Normal” and Double Sideband Suppressed Carrier (DSSC). To change between normal AM and DSSC, use the command:

```
[SOURCE[1|2]]:AM:DSSC {ON|OFF}.
```

In DSSC, the carrier is not present unless the modulating signal has an amplitude greater than zero.

Modulating Source

The waveform generator will accept an internal or external modulation source for AM.

- Modulating source: Internal (default), Other Channel, or External.
- If you select the *External* source, the carrier waveform is modulated with an external waveform. The modulation depth is controlled by the ± 5 V signal level present on the rear-panel *Modulation In* connector. For example, if you have set the modulation depth to 100%, then when the modulating signal is at +5 volts, the output will be at the *maximum* amplitude. When the modulating signal is at -5 volts, then the output will be at the *minimum* amplitude. The external modulation input has -3 dB bandwidth of 100 kHz.

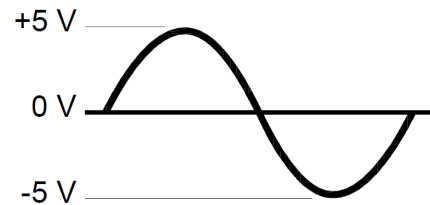
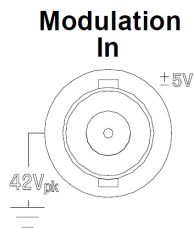

- *Front-Panel Operation:* After enabling AM, press the **Source** softkey.
- *Remote Interface Operation:*

```
AM:SOURce {INTernal|EXTernal|CH1|CH2}
```

Frequency Modulation (FM)

A modulated waveform consists of a *carrier waveform* and a *modulating waveform*. In FM, the frequency of the carrier is varied by the instantaneous voltage of the modulating waveform.

For more information on the fundamentals of Frequency Modulation, refer to chapter 5, “Tutorial.”

To Select FM Modulation

- The waveform generator will allow only one modulation mode to be enabled at a time. When you enable FM, the previous modulation mode is turned off.
- The waveform generator will not allow FM to be enabled when sweep or burst is enabled. When you enable FM, the sweep or burst mode is turned off.
- *Front-Panel Operation:* You must select FM *before* setting up any of the other modulation parameters. Press  and then select **FM** using the **Type** softkey. The FM waveform is output using the present settings for the carrier frequency, modulating frequency, output amplitude, and offset voltage.
- *Remote Interface Operation:* To avoid multiple waveform changes, enable FM *after* you have set up the other modulation parameters.

```
FM:STATE {OFF|ON}
```

Carrier Waveform Shape

- FM carrier shape: Sine (default), Square, Pulse, Triangle, PRBS, UpRamp, DnRamp, or Noise. You cannot use arbitrary waveform or DC as the carrier waveform.
- *Front-Panel Operation:* Press  and select any waveform except **Noise, Arb, or DC**.
- *Remote Interface Operation:*

```
FUNCTION  
{SINusoid|SQUare|RAMP|PULSe|PRBS|NOISe|ARB}
```

You can also use the APPLy command to select the function, frequency, amplitude, and offset with a single command.

Carrier Frequency

The maximum carrier frequency depends on the function selected as shown below. *The default is 1 kHz for all functions.*

Function	Minimum Frequency	Maximum Frequency
Sine	1 μ Hz	30 MHz
Square	1 μ Hz	30 MHz
Ramp	1 μ Hz	200 kHz
Pulse	1 μ Hz	30 MHz
PRBS	1 μ Hz	30 MHz
Noise BW	1 mHz	30 MHz
Arbs	1 μ Sa/sec	250 MSa/sec





- The *carrier frequency* must always be greater than or equal to the frequency deviation. If you attempt to set the deviation to a value greater than the carrier frequency (with FM enabled), the waveform generator will automatically adjust the deviation to the maximum value allowed with the present carrier frequency.
- The sum of the *carrier frequency* and deviation must be less than or equal to the maximum frequency for the selected waveform plus 100 kHz (30.1 MHz for sine and square, and 300 kHz for ramp). If you attempt to set the deviation to an invalid value, the waveform generator will automatically adjust it to the maximum value allowed with the present carrier frequency.
- *Front-Panel Operation:* To set the carrier frequency, press the **Frequency** softkey (under **Parameters**) for the selected function. Then use the knob or numeric keypad to enter the desired frequency.
- *Remote Interface Operation:*

```
[SOURCE [1|2]:] FREQUENCY {<frequency>|MINimum|MAXimum}
```

You can also use the **APPLY** command to select the function, frequency, amplitude, and offset with a single command.

Modulating Waveform Shape

The waveform generator will accept an internal or external modulation source for FM.

- Modulating waveform shape (*internal source*): Sine (default), Square, Pulse, UpRamp, DnRamp, Triangle, Noise, or PRBS.
 - Square has 50% duty cycle 
 - UpRamp has 100% symmetry 
 - Triangle has 50% symmetry 
 - DnRamp has 0% symmetry 
 - Noise - white gaussian noise
 - PRBS - Pseudo Random Bit Sequence (polynomial PN7)
- You can use noise as the modulating waveshape, but you *cannot* use noise, arbitrary waveforms, or **DC** as the carrier waveform.
- *Front-Panel Operation*: After selecting FM, press the **Shape** softkey.
- *Remote Interface Operation*:

```
FM:INTernal:FUNCTion  
  {SINusoid|SQUare|RAMP|NRAMP|TRIangle|  
   NOISe|PRBS|ARB}
```

Modulating Waveform Frequency

The waveform generator will accept an internal or external modulation source for FM.

- Modulating frequency (*internal source*): 1 μ Hz to 30 MHz.
The default is 10 Hz.
- *Front-Panel Operation:* After selecting FM, press the **FM Freq** softkey.
- *Remote Interface Operation:*

```
[SOURCE [1 | 2] :] FM: INTernal: FREquency
{ <frequency> | MINimum | MAXimum }
```

Frequency Deviation

The *frequency deviation* setting represents the peak variation in frequency of the modulated waveform from the carrier frequency.

- Frequency deviation: 1 μ Hz to (carrier frequency)/2. *The default is 100 Hz.*
- The *carrier frequency* must always be greater than or equal to the deviation. If you attempt to set the deviation to a value greater than the carrier frequency (with FM enabled), the waveform generator will limit the deviation to the maximum value allowed with the present carrier frequency.
- The sum of the *carrier frequency* and deviation must be less than or equal to the maximum frequency for the selected function **plus 100 kHz** (30.1 MHz for sine and square and 300 kHz for ramp). If you attempt to set the deviation to a value that is not valid, the waveform generator will limit it to the maximum value allowed with the present carrier frequency.
- *Front-Panel Operation:* After enabling FM, press the **Freq Dev** softkey. Then use the knob or numeric keypad to enter the desired deviation.
- *Remote Interface Operation:*

```
FM: DEVIation { <peak_deviation_in_Hz> | MINimum | MAXimum }
```

Modulating Source

The waveform generator will accept an internal or external modulation source for FM.

- Modulating source: Internal (default), Other Channel, or External.
- If you select the *External* source, the carrier waveform is modulated with an external waveform. The frequency deviation is controlled by the ± 5 V signal level present on the rear-panel *Modulation In* connector. For example, if you have set the deviation to 10 kHz, then a +5 V signal level corresponds to a 10 kHz increase in frequency. Lower external signal levels produce less deviation and negative signal levels reduce the frequency below the carrier frequency. The external modulation input has -3 dB bandwidth of 100 kHz.

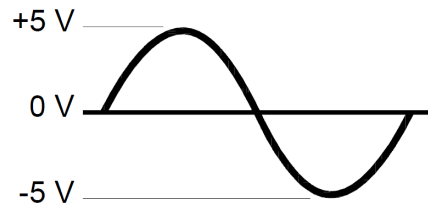
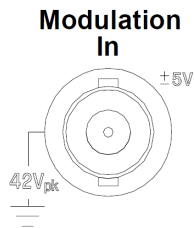

- *Front-Panel Operation:* After selecting FM, press the **Source** softkey.
- *Remote Interface Operation:*

```
FM:SOURce {INTernal|EXTernal|CH1|CH2}
```

Phase Modulation (PM)

A modulated waveform consists of a *carrier waveform* and a *modulating waveform*. PM is very similar to FM, but in PM the *phase* of the modulated waveform is varied by the instantaneous voltage of the modulating waveform.

For more information on the fundamentals of Phase Modulation, refer to chapter 5, “Tutorial.”

To Select PM Modulation

- The waveform generator will allow only one modulation mode to be enabled at a time. When you enable PM, the previous modulation mode is turned off.
- The waveform generator will not allow PM to be enabled when sweep or burst is enabled. When you enable PM, the sweep or burst mode is turned off.
- *Front-Panel Operation:* You must select PM *before* setting up any of the other modulation parameters. Press **Modulate** and then select **PM** using the **Type** softkey. The PM waveform is output using the present settings for the carrier frequency, modulating frequency, output amplitude, and offset voltage.
- *Remote Interface Operation:* To avoid multiple waveform changes, enable PM *after* you have set up the other modulation parameters.

```
PM:STATe {OFF|ON}
```

Carrier Waveform Shape

- PM carrier shape: Sine (default), Square, Pulse, PRBS, Ramp, or Arbitrary waveform. You *cannot* use Noise or DC as the carrier waveform.
- *Front-Panel Operation:* Press  and select any waveform except **Noise** or **DC**. To select an arbitrary waveform, press **Arb** and **Arbs**, and then press **Select Arb** to select the active waveform.
- *Remote Interface Operation:*

```
FUNCTION
{SINusoid|SQUare|RAMP|PULSe|PRBS|NOISE|ARB}
```

You can also use the **APPLY** command to select the function, frequency, amplitude, and offset with a single command.

Carrier Frequency

The maximum carrier frequency depends on the function selected as shown below. Carrier frequency must be greater than 20 times the peak modulation frequency. *The default is 1 kHz for all functions.*

Function	Minimum Frequency	Maximum Frequency
Sine	1 μ Hz	30 MHz
Square	1 μ Hz	30 MHz
Ramp/Tri.	1 μ Hz	200 kHz
Pulse	1 μ Hz	30 MHz
PRBS	1 μ Hz	30 MHz
Noise BW	1 mHz	30 MHz
Arbs	1 μ Sa/sec	250 MSa/sec

Front-Panel Operation: To set the carrier frequency, press the **Frequency** softkey for the selected function. Then use the knob or numeric keypad to enter the desired frequency.





- *Remote Interface Operation:*

```
[SOURCE [1|2] :] FREQUENCY {<frequency>|MINimum|MAXimum}
```

You can also use the **APPLY** command to select the function, frequency, amplitude, and offset with a single command.

Modulating Waveform Shape

The waveform generator will accept an internal or external modulation source for PM.

- Modulating waveform shape (*internal source*): Sine (default), Square, Pulse, UpRamp, DnRamp, Triangle, Noise, or PRBS.
 - Square has 50% duty cycle 
 - UpRamp has 100% symmetry 
 - Triangle has 50% symmetry 
 - DnRamp has 0% symmetry 
 - Noise - white gaussian noise
 - PRBS - Pseudo Random Bit Sequence (polynomial PN7)
- You can use noise as the modulating waveshape, but you *cannot* use noise, arbitrary waveforms, or DC as the carrier waveform.
- *Front-Panel Operation:* After enabling PM, press the **Shape** softkey.
- *Remote Interface Operation:*

```
PM:INTernal:FUNCTION {SINusoid|SQUare|RAMP|NRAMP|  
TRIangle|NOISe|PRBS|ARB}
```

Phase Modulation (PM)**Modulating Waveform Frequency**

The waveform generator will accept an internal or external modulation source for PM. The external modulation input has a -3dB bandwidth of 100 kHz.

- Modulating frequency (*internal source*): 1 μ Hz to 30 MHz. *The default is 10 Hz.*
- *Front-Panel Operation:* After enabling PM, press the **PM Freq** softkey.
- *Remote Interface Operation:*

```
[SOURCE [1|2] :] PM:INTernal:FREQuency
  {<frequency> | MINimum | MAXimum}
```

Phase Deviation

The *phase deviation* setting represents the peak variation in phase of the modulated waveform from the carrier waveform. The phase deviation can be set from 0 to 360 degrees. The default is 180 degrees.

- *Front-Panel Operation:* After enabling PM, press **Phase Dev**. Then use the knob or numeric keypad to enter the desired deviation.
- *Remote Interface Operation:*

```
PM:DEVIation {<deviation_in_degrees> | MINimum | MAXimum}
```

Modulating Source

The waveform generator will accept an internal or external modulation source for PM.

- Modulating source: Internal (default), Other Channel, or External.
- If you select the *External* source, the carrier waveform is modulated with an external waveform. The phase deviation is controlled by the ± 5 V signal level present on the rear-panel *Modulation In* connector. For example, if you have set the deviation to 180 degrees, then a +5 V signal level corresponds to a 180 degree phase shift. Lower external signal levels produce less deviation.

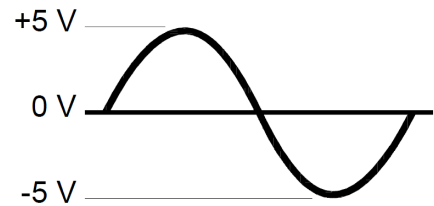
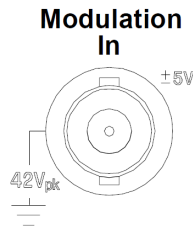

- *Front-Panel Operation:* After enabling PM, press the **Source** softkey.
- *Remote Interface Operation:*

```
PM:SOURce {INTernal|EXTernal}
```

Frequency-Shift Keying (FSK) Modulation

You can configure the waveform generator to “shift” its output frequency between two preset values using FSK modulation. The rate at which the output shifts between the two frequencies (called the “carrier frequency” and the “hop frequency”) is determined by the internal rate generator or the signal level on the rear-panel *Ext Trig* connector.

For more information on the fundamentals of FSK Modulation, refer to chapter 5, “Tutorial.”

To Select FSK Modulation

- The waveform generator will allow only one modulation mode to be enabled at a time. When you enable FSK, the previous modulation mode is turned off.
- The waveform generator will not allow FSK to be enabled when sweep or burst is enabled. When you enable FSK, the sweep or burst mode is turned off.
- *Front-Panel Operation:* You must enable FSK *before* setting up any of the other modulation parameters. Press **Modulate** and then select **FSK** using the **Type** softkey. The FSK waveform is output using the present settings for the carrier frequency, output amplitude, and offset voltage.
- *Remote Interface Operation:* To avoid multiple waveform changes, enable FSK *after* you have set up the other modulation parameters.

```
FSKey:STATE {OFF|ON}
```

FSK Carrier Frequency

The maximum carrier frequency depends on the function selected as shown below. *The default is 1 kHz for all functions.*

Function	Minimum Frequency	Maximum Frequency
Sine	1 μ Hz	30 MHz
Square	1 μ Hz	30 MHz
Ramp	1 μ Hz	200 kHz
Pulse	1 μ Hz	30 MHz

When the *External* source is selected, the output frequency is determined by the signal level on the rear-panel *Ext Trig* connector. When a logic *low* level is present, the *carrier* frequency is output. When a logic *high* level is present, the *hop* frequency is output.

- *Front-Panel Operation:* To set the carrier frequency, press the **Freq** softkey for the selected function. Then use the knob or numeric keypad to enter the desired frequency.
- *Remote Interface Operation:*

```
[SOURCE [1 | 2] :] FREQUENCY {<frequency> | MINimum | MAXimum}
```

You can also use the `APPLY` command to select the function, frequency, amplitude, and offset with a single command.

FSK “Hop” Frequency

The maximum alternate (or “hop”) frequency depends on the function selected as shown below. *The default is 100 Hz for all functions.*

Function	Minimum Frequency	Maximum Frequency
Sine	1 μ Hz	30 MHz
Square	1 μ Hz	30 MHz
Ramp/Tri.	1 μ Hz	200 kHz
Pulse	1 μ Hz	30 MHz
PRBS	1 μ Hz	30 MHz
Noise BW	1 mHz	30 MHz
Arbs	1 μ Sa/sec	250 MSa/sec

The internal modulating waveform is a *square wave* with a 50% duty cycle.

- When the *External* source is selected, the output frequency is determined by the signal level on the rear-panel *Ext Trig* connector. When a logic *low* level is present, the *carrier* frequency is output. When a logic *high* level is present, the *hop* frequency is output.
- *Front-Panel Operation:* To set the “hop” frequency, press the **Hop Freq** softkey. Then use the knob or numeric keypad to enter the desired frequency.
- *Remote Interface Operation:*

```
[SOURce [1 | 2] :] FSKey:FREQuency  
{ <frequency> | MINimum | MAXimum }
```

FSK Rate

The *FSK rate* is the rate at which the output frequency “shifts” between the carrier frequency and the hop frequency when you select the internal FSK source.

- FSK rate (*internal source*): 125 μ Hz to 1 MHz. *The default is 10 Hz.*
- The FSK rate is ignored when the external FSK source is selected.
- *Front-Panel Operation:* To set the FSK rate, press the **FSK Rate** softkey. Then use the knob or numeric keypad to enter the desired rate.
- *Remote Interface Operation:*

```
FSKey:INTernal:RATE {<rate_in_Hz>|MINimum|MAXimum}
```

FSK Source

- FSK source: Internal (default) or External.
- When the *Internal* source is selected, the rate at which the output frequency “shifts” between the carrier frequency and hop frequency is determined by the *FSK rate* specified.
- When the *External* source is selected, the output frequency is determined by the signal level on the rear-panel *Ext Trig* connector. When a logic *low* level is present, the *carrier* frequency is output. When a logic *high* level is present, the *hop* frequency is output.
- The maximum external FSK rate is 1 MHz.
- The connector used for externally-controlled FSK waveforms (*Ext Trig*) is not the same connector that is used for externally-modulated AM, FM, PM, and PWM waveforms (*Modulation In*). When used for FSK, the *Ext Trig* connector *does not* have adjustable edge polarity.
- *Front-Panel Operation:* After enabling FSK, press **Source** and choose the desired source.
- *Remote Interface Operation:*



```
FSKey:SOURce {INTernal|EXTernal}
```

Pulse Width Modulation (PWM)

In Pulse Width Modulation (PWM), the width of a pulse waveform is varied by the instantaneous voltage of the modulating waveform. The width of the pulse can be expressed either as a *pulse width* (expressed in time units, like the period) or a *duty cycle* (expressed as a percentage of the period). The waveform generator will accept an internal or external modulation source.

For more information on the fundamentals of Pulse Width Modulation, refer to chapter 5, “Tutorial.”

To Select PWM Modulation

- The waveform generator only allows PWM to be selected for a pulse waveform.
- The waveform generator will not allow PWM to be enabled when sweep or burst is enabled.
- *Front-Panel Operation:* You must enable PWM *before* setting up any of the other modulation parameters. Press , select **Pulse**, and then press  and **Modulate** to turn on modulation. PWM is selected as the only modulation type supported for pulse. The PWM waveform is output using the present settings for the pulse frequency, modulating frequency, output amplitude, offset voltage, pulse width, and edge time.
- *Remote Interface Operation:* To avoid multiple waveform changes, enable PWM *after* you have set up the other modulation parameters.

```
PWM:STATE {OFF|ON}
```

Modulating Waveform Shape

The waveform generator will accept an internal or external modulation source for PWM.

- Modulating waveform shape (*internal source*): Sine (default), Square, Pulse, UpRamp, DnRamp, Triangle, Noise, or PRBS.

- Square has 50% duty cycle 

- UpRamp has 100% symmetry 

- Triangle has 50% symmetry 

- DnRamp has 0% symmetry 

- Noise - white gaussian noise

- PRBS - Pseudo Random Bit Sequence (polynomial PN7)

- You can use noise as the modulating waveshape, but you *cannot* use noise, arbitrary waveforms, or DC as the carrier waveform.

- *Front-Panel Operation:* After enabling PWM, press the **Shape** softkey.

- *Remote Interface Operation:*

```
PWM:INTernal:FUNCTION {SINusoid|SQUare|RAMP|NRAMP|  
TRIangle|NOISE|PRBS|ARB}
```

Modulating Waveform Frequency

The waveform generator will accept an internal or external modulation source for PWM. The external modulation input has a -3dB bandwidth of 100 kHz.

- Modulating frequency (*internal source*): 1 μ Hz to 30 MHz. *The default is 10 Hz.*
- *Front-Panel Operation:* After enabling PM, press the **PWM Freq** softkey.
- *Remote Interface Operation:*

```
[SOURCE [1 | 2] :] PWM:INTernal:FREQuency  
  {<frequency> | MINimum | MAXimum}
```

Phase Deviation

The *phase deviation* setting represents the peak variation in phase of the modulated waveform from the carrier waveform. The phase deviation can be set from 0 to 360 degrees. The default is 180 degrees.

- *Front-Panel Operation:* After enabling PWM, press **Phase Dev**. Then use the knob or numeric keypad to enter the desired deviation.
- *Remote Interface Operation:*

```
PWM:DEVIation {<deviation_in_degrees> | MINimum | MAXimum}
```

Modulating Source

The waveform generator will accept an internal or external modulation source for PM.

- Modulating source: Internal (default), Other Channel, or External.
- If you select the *External* source, the carrier waveform is modulated with an external waveform. The phase deviation is controlled by the ± 5 V signal level present on the rear-panel *Modulation In* connector. For example, if you have set the deviation to 180 degrees, then a +5 V signal level corresponds to a 180 degree phase shift. Lower external signal levels produce less deviation.

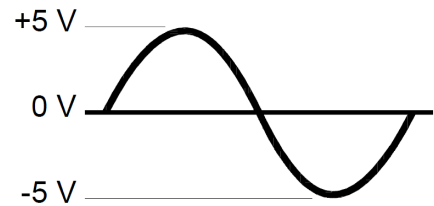
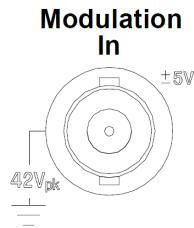

- *Front-Panel Operation:* After enabling PM, press the **Source** softkey.
- *Remote Interface Operation:*

```
PM:SOURce {INTernal|EXTernal}
```

Pulse Waveform

- Pulse is the only waveform shape supported for PWM.
- *Front-Panel Operation:* Press , then **Pulse**.
- *Remote Interface Operation:*

```
FUNCTION PULSe
```

You can also use the APPLy command to select the function, frequency, amplitude, and offset with a single command.

Pulse Period

The range for the pulse period is 33 ns to 1,000,000 s. The default is 100 μ s.

- *Front-Panel Operation:* After selecting the pulse function, press  and the **Frequency/Period** softkey to toggle to the **Period** setting. Then use the knob or numeric keypad to enter the desired pulse period. If you use the numeric keypad, press a softkey to specify the units.
- *Remote Interface Operation:*

```
FUNCTION:PULSe:PERiod {<seconds>|MINimum|MAXimum}
```

Sum Modulation (Sum)

In Sum Modulation (Sum), the modulating signal is added to the carrier waveform. A typical use is adding gaussian noise to a carrier signal. The waveform generator will accept an internal or external modulation source.

For more information on the fundamentals of a sweep, refer to chapter 5, “Tutorial.”





To Select Sum Modulation

- The waveform generator allows a modulating signal to be added to the carrier as a percentage of the carrier waveform amplitude in resolution of 0.01%.
- The waveform generator will allow Sum modulation to be added to any carrier waveform.
- *Front-Panel Operation:* You must enable Sum *before* setting up any of the other modulation parameters. Press **Waveforms**, then select **Square**. Press **Modulate** and then press **Type** and **Sum**. At this point, you can specify the other modulation parameters. Once you have done so, press **Modulate** to turn on modulation.
- *Remote Interface Operation:* To avoid multiple waveform changes, enable Sum *after* you have set up the other modulation parameters.

```
SUM:STATE {OFF|ON}
```

Modulating Waveform Shape

The waveform generator will accept an internal or external modulation source for Sum.

- Modulating waveform shape (*internal source*): Sine (default), Square, Pulse, UpRamp, DnRamp, Triangle, Noise, PRBS, or Arb waveform.
 - Square has 50% duty cycle 
 - UpRamp has 100% symmetry 
 - Triangle has 50% symmetry 
 - DnRamp has 0% symmetry 
 - PRBS uses PN7 sequence.
- *Front-Panel Operation:* After enabling Sum, press the **Shape** softkey.
- *Remote Interface Operation:*

```
SUM:INTernal:FUNCTion  
  {SINusoid|SQUare|PULSe|RAMP|NRAMP|TRIangle|  
  NOISe|PRBS}
```

Modulating Waveform Frequency

The waveform generator will accept an internal or external modulation source for Sum.

- Modulating frequency (*internal source*): 1 μ Hz to 30 MHz.
The default is 100 Hz.
- *Front-Panel Operation:* After enabling Sum, press the **Sum Freq** softkey.
- *Remote Interface Operation:*

```
[SOURCE [1 | 2] :]SUM:INTernal:FREQuency  
  {<frequency>|MINimum|MAXimum}
```

Sum Amplitude

The sum amplitude represents the amplitude of the signal added to the carrier (in percent of carrier amplitude).

- Amplitude setting: 0 to 100% of carrier amplitude, 0.01% resolution.
- The Sum Amplitude setting remains a constant fraction of the carrier amplitude and tracks carrier amplitude changes.
- *Front-Panel Operation:* After selecting Sum, press the **Sum Ampl** softkey. Then use the knob or numeric keypad to enter the desired amplitude.
- *Remote Interface Operation:*

```
SUM:AMPLitude {<amplitude>|MINimum|MAXimum}
```

Modulating Source

The waveform generator will accept an internal or external modulation source for Sum.

- Modulating source: Internal (default), Other Channel, or External.
- If you select the External source, the carrier waveform is summed with an external waveform. The amplitude is controlled by the ± 5 V signal level present on the rear-panel Modulation In connector. For example, if you have set the sum amplitude to 10%, then when the modulating signal is at +5 V, the output will be at the maximum amplitude (110% of carrier amplitude). When the modulating signal is at -5 volts, the output will be at the minimum amplitude (90% of Carrier amplitude).

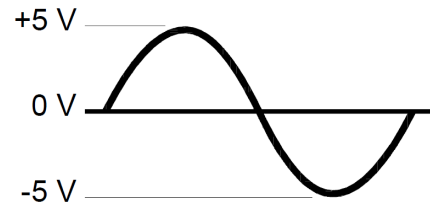
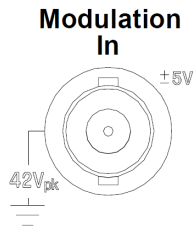

- *Front-Panel Operation:* After enabling Sum, press the **Source** softkey.
- *Remote Interface Operation:*

```
SUM:SOURce {INTernal|EXTernal|CH1|CH2}
```

Frequency Sweep

In the frequency sweep mode, the waveform generator moves from the *start frequency* to the *stop frequency* at a *sweep rate* which you specify. You can sweep up or down in frequency, with either linear or logarithmic spacing. You can also configure the waveform generator to output a single sweep (one pass from start frequency to stop frequency) by applying an external or manual trigger. The waveform generator can produce a frequency sweep for sine, square, pulse, ramp, or arbitrary waveforms (PRBS, noise and DC are not allowed).

You can specify a hold time, during which the sweep remains at the stop frequency. You can also specify a return time, during which the frequency changes linearly from the stop frequency to the start frequency.

For more information on the fundamentals of a sweep, refer to chapter 5, “Tutorial.”

To Select Sweep

- The waveform generator will not allow the sweep mode to be enabled at the same time that burst or any modulation mode is enabled. When you enable sweep, the burst or modulation mode is turned off.
- *Front-Panel Operation:* You must enable sweep *before* setting up any of the other sweep parameters. Press  and then press **Sweep** to output a sweep using the present settings for frequency, output amplitude, and offset.
- *Remote Interface Operation:* To avoid multiple waveform changes, enable the sweep mode *after* you have set up the other parameters.

```
FREQuency:MODE SWEEP  
SWEep:STATe {OFF|ON}
```

Start Frequency and Stop Frequency

The *start frequency* and *stop frequency* set the upper and lower frequency bounds for the sweep. The waveform generator begins at the start frequency, sweeps to the stop frequency, and then resets back to the start frequency.

- Start and Stop frequencies: 1 μ Hz to 30 MHz (limited to 200 kHz for ramps). The sweep is phase continuous over the full frequency range. *The default start frequency is 100 Hz. The default stop frequency is 1 kHz.*
- To sweep **up** in frequency, set the start frequency less than the stop frequency. To sweep **down** in frequency, set the start frequency greater than the stop frequency.
- When the Sync setting is set to Normal, the sync pulse goes high during the whole sweep.
- When the Sync setting is set to Carrier, the sync pulse has a 50% duty cycle for every waveform cycle.
- When the Sync setting is set to Marker, the sync pulse goes high at the beginning and goes low at the marker frequency.
- *Front-Panel Operation:* After enabling sweeps, press the **Start Freq** or **Stop Freq** softkey. Then use the knob or numeric keypad to enter the desired frequency.
- *Remote Interface Operation:*

```
[SOURce [1 | 2] :] FREQuency: START  
  {<frequency> | MINimum | MAXimum}  
[SOURce [1 | 2] :] FREQuency: STOP  
  {<frequency> | MINimum | MAXimum}
```

Center Frequency and Frequency Span

If desired, you can set the frequency boundaries of the sweep using a *center frequency* and *frequency span*. These parameters are similar to the start frequency and stop frequency (*see the previous page*) and are included to give you added flexibility.

- Center frequency: 1 μ Hz to 30 MHz (limited to 300 kHz for ramps).
The default is 550 Hz.
- Frequency span: -30 Hz to 30 MHz (limited to 300 kHz for ramps).
The default is 900 Hz.
- To sweep **up** in frequency, set a *positive* frequency span.
 To sweep **down** in frequency, set a *negative* frequency span.
- For sweeps with *Marker Off*, the Sync signal is a square waveform with a 50% duty cycle. The Sync signal is a TTL “high” at the beginning of the sweep and goes “low” at the midpoint of the sweep. The frequency of the sync waveform is equal to the specified sweep time. The signal is output from the front-panel *Sync* connector.
- For sweeps with *Marker On*, the Sync signal is a TTL “high” at the beginning of the sweep and goes “low” at the marker frequency. The signal is output from the front-panel *Sync* connector.
- *Front-Panel Operation:* After enabling sweeps, press  and then press **Start/Stop** to toggle to the **Cntr/Span** softkey. Then use the knob or numeric keypad to enter the desired values.
- *Remote Interface Operation:*

```
[SOURce [1 | 2] :] FREQuency: CENTer
  { <frequency> | MINimum | MAXimum }
[SOURce [1 | 2] :] FREQuency: SPAN
  { <frequency> | MINimum | MAXimum }
```

Sweep Mode

You can sweep with either linear or logarithmic spacing. For a *linear* sweep, the waveform generator varies the output frequency linearly during the sweep. For a *logarithmic* sweep, the waveform generator varies the output frequency logarithmically.

The selected mode does not affect the sweep return (from stop to start, if one is set). The sweep return is always linear.

- Sweep mode: Linear (default), Logarithmic, or List.
- *Front-Panel Operation:* After enabling sweeps, press the **Linear** softkey again to toggle between the linear or log mode.
- *Remote Interface Operation:*

```
[SOURCE[1|2]:]SWEep:SPACing {LINEar|LOGarithmic}
```

Sweep Time

The *sweep time* specifies the number of seconds required to sweep from the start frequency to the stop frequency. The number of discrete frequency points in the sweep is automatically calculated by the waveform generator based on the sweep time.

- Sweep time: 1 ms to 250,000 seconds. *The default is 1 second.*
- *Front-Panel Operation:* After enabling sweeps, press **Sweep Time**. Then use the knob or numeric keypad to enter the desired sweep time.
- *Remote Interface Operation:*

```
[SOURCE[1|2]:]SWEep:TIME {<seconds>|MINimum|MAXimum}
```

Hold Time

The *hold time* specifies the number of seconds to remain at the stop frequency. This allows the stop frequency to be sustained for a set time. By default, this value is zero and the sweep will immediately return to the start frequency.

- Hold time: 0 to 3600 seconds. The default is 0 seconds.
- *Front-Panel Operation:* After enabling sweeps, press **Hold & Return** and then the **Hold Time** softkey. Then use the knob or numeric keypad to enter the desired sweep time.
- *Remote Interface Operation:*

```
SWEep:HTIME {<seconds>|MINimum|MAXimum}
```

Return Time

The *return time* specifies the number of seconds to return from the stop frequency to the start frequency. The number of discrete frequency points in the return is automatically calculated by the waveform generator and is based on the return time you select.

- Hold time: 0 to 3600 seconds. The default is 0 seconds.
- *Front-Panel Operation:* After enabling sweeps, press **Hold & Return** and then the **Return Time** softkey. Then use the knob or numeric keypad to enter the desired sweep time.
- *Remote Interface Operation:*

```
SWEep:RTIME {<seconds>|MINimum|MAXimum}
```

Marker Frequency



If desired, you can set the frequency at which the signal on the front-panel *Sync* connector goes to a logic low during the sweep. The Sync signal always goes from low to high at the beginning of the sweep.

- Marker frequency: 1 μ Hz to 30 MHz (limited to 200 kHz for ramp). *The default is 500 Hz.*
- When the sweep mode is enabled, the marker frequency *must* be between the specified start frequency and stop frequency. If you attempt to set the marker frequency to a frequency not in this range, the waveform generator will automatically set the marker frequency equal to the start frequency or stop frequency (whichever is closer).
- The Sync enable setting is overridden by enabling the marker used with the sweep mode (*see page 107*). Therefore, when the marker is enabled (and the sweep mode is also enabled), the Sync setting is ignored.
- *Front-Panel Operation:* After enabling a sweep, press , then **Sync Setup**. Then press **Mode** and **Marker**. Finally, press **Marker Freq**. Then use the knob or numeric keypad to enter the desired marker frequency.
- *Remote Interface Operation:*

```
[SOURCE [1 | 2] :] MARKer : FREQuency  
{ <frequency> | MINimum | MAXimum }
```

Sweep Trigger Source

In the sweep mode, the waveform generator outputs a single sweep when a trigger signal is received. After one sweep from the start frequency to the stop frequency, the waveform generator waits for the next trigger while outputting the start frequency.

- Sweep trigger source: Internal (default), External, Time, or Manual.
- When the *Internal* (immediate) source is selected, the waveform generator outputs a continuous sweep at a rate determined by the total of the hold time, sweep time and return time.
- When the *External* source is selected, the waveform generator will accept a hardware trigger applied to the rear-panel *Ext Trig* connector. The waveform generator initiates one sweep each time *Ext Trig* receives a TTL pulse with the specified polarity.
- The trigger period must be greater than or equal to the specified sweep time.
- When the *Manual* source is selected, the waveform generator outputs one sweep each time the front-panel  key is pressed.
- *Front-Panel Operation:* Press , then the **Trigger Setup** softkey. Press **Trg Src** and then select the desired source.

To specify whether the waveform generator triggers on the rising or falling edge of the *Ext Trig* connector, press , then the **Trigger Setup** softkey. Then select the desired edge by pressing the **Slope** softkey.

- *Remote Interface Operation:*

```
TRIGger[1|2]:SOURce {IMMediate|EXTernal|TIMer|BUS}
```

Use the following command to specify whether the waveform generator triggers on the rising or falling edge of the signal on the *Ext Trig* connector.

```
TRIGger[1|2]:SLOPe {POSitive|NEGative}
```

See “Triggering” on page 161 for more information.

Trigger Out Signal

A “trigger out” signal is provided on the rear-panel *Trig Out* connector (*used with sweep and burst* only). When enabled, a TTL-compatible square waveform with either a rising edge (default) or falling edge is output from the *Trig Out* connector at the beginning of the sweep.

- When the *Internal* (immediate) trigger source is selected, the waveform generator outputs a square waveform with a 50% duty cycle from the *Trig Out* connector at the beginning of the sweep. The frequency of the waveform is equal to the specified total sweep time.
- When the *External* trigger source is selected, the waveform generator automatically disables the “trigger out” signal. The *Trig Out* connector cannot be used for both operations at the same time (an externally-triggered waveform uses the same connector to trigger the sweep).
- When the *Manual* trigger source is selected, the waveform generator outputs a pulse ($>1 \mu\text{s}$ pulse width) from the *Trig Out* connector at the beginning of each sweep or burst.
- To specify whether the waveform generator triggers on the rising or falling edge of the *Ext Trig* connector, press , then the **Trig Out Setup** softkey. Then select the desired edge by pressing the **Trig Out** softkey.
- *Remote Interface Operation:*

```
OUTPut:TRIGger:SLOPe {POSitive|NEGative}  
OUTPut:TRIGger {OFF|ON}
```

Frequency List

In the frequency list mode, the function generator “steps” through the frequencies contained in a list, dwelling on each frequency for a specified period. You may also control progress through the list with the trigger system.

- The function generator will not allow the list mode to be enabled at the same time that burst or any modulation mode is enabled. When you enable frequency list, the burst or modulation mode is turned off.
- Front-Panel Operation: You must enable list before setting up any of the other list parameters. Press **Sweep**, the **Type**, then **List** to begin setting up a list. This will open the menu shown below:

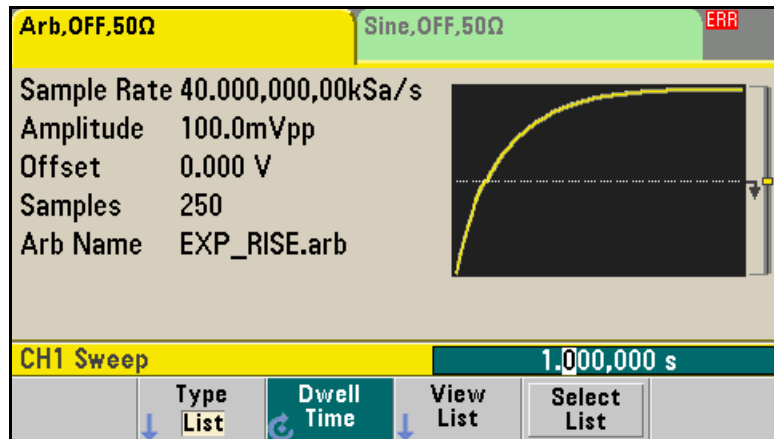

- *Remote Interface Operation:* To avoid multiple waveform changes, enable the list mode after you have set up its parameters.

FREQUENCY:MODE LIST

LIST:FREQUENCY <number>, <number>, ...

Progress through list is controlled by the trigger system. If the trigger source is set to internal or immediate, the dwell time setting (LIST:DWELL command) determines time spent at each frequency.

For any other trigger source, the dwell time is determined by trigger event spacing.

Burst Mode

You can configure the waveform generator to output a waveform with a specified number of cycles, called a *burst*. The waveform generator can produce a burst using sine, square, triangle, ramp, pulse, PRBS, or arbitrary waveforms (noise is allowed only in the gated burst mode and DC is not allowed).

For more information on the fundamentals of the burst mode, refer to chapter 5, “Tutorial.”

To Select Burst

- The waveform generator will not allow burst to be enabled at the same time that sweep or any modulation mode is enabled. When you enable burst, the sweep, list, or modulation mode is turned off.
- *Front-Panel Operation:* You must enable burst *before* setting up any of the other burst parameters. Press **Burst On/Off** to output a burst using the present settings for frequency, output amplitude, and offset voltage.
- *Remote Interface Operation:* To avoid multiple waveform changes, enable the burst mode *after* you have set up the other parameters.

```
[SOURce[1|2]:]BURSt:STATe {OFF|ON}
```

Burst Mode

You can use burst in one of two modes as described below. The selected mode controls the allowable trigger source that you selected, and whether certain other burst parameters apply (see the table below).

- Triggered Burst Mode:* In this mode (default), the waveform generator outputs a waveform with a specified number of cycles (*burst count*) each time a trigger is received. After the specified number of cycles have been output, the waveform generator stops and waits for the next trigger. You can configure the waveform generator to use an internal trigger to initiate the burst or you can provide an external trigger by pressing the front-panel  key, applying a trigger signal to the rear-panel *Ext Trig* connector, or sending a software trigger command from the remote interface.
- External Gated Burst Mode:* In this mode, the output waveform is either “on” or “off” based on the level of the external signal applied to the rear-panel *Ext Trig* connector. When the gate signal is *true*, the waveform generator outputs a continuous waveform. When the gate signal goes *false*, the current waveform cycle is completed and then the waveform generator stops while remaining at the voltage level corresponding to the starting burst phase of the selected waveform. For a noise waveform, the output stops immediately when the gate signal goes false.

	Burst Mode (BURS:MODE)	Burst Count (BURS:NCYC)	Burst Period (BURS:INT:PER)	Burst Phase (BURS:PHAS)	Trigger Source (TRIG:SOUR)
Triggered Burst Mode: Internal Trigger	TRIGgered	Available	Available	Available	IMMediate
Triggered Burst Mode: External Trigger	TRIGgered	Available	Not Used	Available	EXTErnal, BUS
Gated Burst Mode: External Trigger	GATed	Not Used	Not Used	Available	Not Used
Timer Burst Mode: Internal Trigger	TRIGgered	Available	Not Used	Available	TIMer

Burst Mode

- When the *gated* mode is selected, the burst count, burst period, and trigger source are ignored (these parameters are used for the triggered burst mode only). If a manual trigger is received, it is ignored and no error will be generated.
- When the *gated* mode is selected, you can also select the polarity of the signal on the rear-panel *Ext Trig* connector.
- *Front-Panel Operation:* After enabling bursts, press the **N Cycle** (triggered) or **Gated** softkey.

Remote Interface Operation:

```
[SOURce[1|2]:]BURSt:MODE {TRIGgered|GATed}
```

Use the following command to select the polarity of the external gate signal on the *Ext Trig* connector. The default is NORM (true-high logic).

```
[SOURce[1|2]:]BURSt:GATE:POLarity {NORMal|INVerted}
```

Waveform Frequency

The *waveform frequency* defines the signal frequency during the burst in the triggered and external gated modes. In the *triggered mode*, the number of cycles specified by the *burst count* is output at the waveform frequency. In the *external gated mode*, the waveform frequency is output when the external gate signal is true.

Keep in mind that the waveform frequency is different than the “burst period” which specifies the interval between bursts (triggered mode only).

- Waveform frequency: 1 μ Hz to 30 MHz (limited to 200 kHz for ramps). *The default waveform frequency is 1 kHz.* (For an *internally triggered* burst waveform, the minimum frequency is 126 μ Hz.) You can select a sine, square, triangle, ramp, pulse, or arbitrary waveform (noise is allowed only in the gated burst mode and DC is not allowed).
- *Front-Panel Operation:* To set the waveform frequency, press the **Freq** softkey for the selected function. Then use the knob or numeric keypad to enter the desired frequency.
- *Remote Interface Operation:*

```
[SOURCE [1 | 2] :] FREQUENCY {<frequency> | MINimum | MAXimum}
```

You can also use the `APPLY` command to select the function, frequency, amplitude, and offset with a single command.

Burst Mode**Burst Count**

The burst count defines the number of cycles to be output per burst.
Used in the triggered burst mode only (internal or external source).

- Burst count: 1 to 100,000,000 cycles, in 1 cycle increments. You can also select an infinite burst count. *The default is 1 cycle.*
- When the *Internal* trigger source is selected, the specified number of cycles is output continuously at a rate determined by the *burst period* setting. The burst period is the time between the starts of consecutive bursts.
- When the *Internal* trigger source is selected, the burst count must be less than the product of the burst period and the waveform frequency as shown below.

$$\text{Burst Period} > (\text{Burst Count})/(\text{Waveform Frequency}) + 1\mu\text{sec}$$

- The waveform generator will automatically increase the burst period up to its maximum value to accommodate the specified burst count (but the waveform frequency *will not* be changed).
- When the *gated* burst mode is selected, the burst count is ignored. However, if you change the burst count from the remote interface while in the gated mode, the waveform generator remembers the new count and will use it when the triggered mode is selected.
- *Front-Panel Operation:* To set the burst count, press  and then the **# Cycles** softkey. Then use the knob or numeric keypad to enter the count. To select an infinite count burst instead, press the **# Cycles** softkey again to toggle to the **Infinite** setting.
- *Remote Interface Operation:*

```
[SOURCE [1|2] :]BURSt:NCYCles
  {<num_cycles>|INFinity|MINimum|MAXimum}
```

Burst Period

The *burst period* defines time from the start of one burst to the start of the next burst. *Used in the internal triggered burst mode only.*

Keep in mind that burst period is different than the “waveform frequency” which specifies the frequency of the bursted signal.

- Burst period: 1 μ s to 8000 seconds. *The default is 10 ms.*
- The burst period setting is used only when Immediate triggering is enabled. The burst period is ignored when manual or external triggering is enabled (or when the *gated* burst mode is selected).
- It *is not* possible to specify a burst period which is too short for the waveform generator to output with the specified burst count and frequency (*see below*). If the burst period is too short, the waveform generator will automatically adjust it as needed to continuously re-trigger the burst.
- *Front-Panel Operation:* To set the burst period, press  and then the **Burst Period** softkey. Then use the knob or numeric keypad to enter the period.
- *Remote Interface Operation:*

```
[SOURCE[1|2]:]BURSt:INTernal:PERiod
  {<seconds>|MINimum|MAXimum}
```

Start Phase



The *start phase* defines the start phase of the burst.

- Start phase: -360 degrees to +360 degrees. *The default is 0 degrees.*
- From the remote interface, you can set the start phase in degrees or radians using the `UNIT:ANGL` command (see the *Agilent 33500 Series Programmer's Reference Help* for details).
- From the front panel, the starting phase is always displayed in degrees (radians are not available). If you set the starting phase in radians from the remote interface and then return to front-panel operation, the waveform generator converts the phase to degrees.
- For sine, square, and ramp waveforms, 0 degrees is the point at which the waveform crosses zero volts (or the DC offset value) in a positive-going direction. For arbitrary waveforms, 0 degrees is the first waveform point downloaded to memory. The burst phase has no effect on noise waveforms.
- The burst phase is also used in the *gated* burst mode. When the gate signal goes *false*, the current waveform cycle is completed and then the waveform generator stops. The output will remain at the voltage level corresponding to the starting burst phase.
- *Front-Panel Operation:* To set the burst phase, press  and then the **Start Phase** softkey. Then use the knob or numeric keypad to enter the desired phase in degrees.
- *Remote Interface Operation:*

```
[SOURce [1|2] :]BURSt:PHASe {<angle>|MINimum|MAXimum}
```

Burst Trigger Source

In the *triggered* burst mode, the waveform generator outputs a burst with the specified number of cycles (*burst count*) each time a trigger is received. After the specified number of cycles have been output, the waveform generator stops and waits for the next trigger. *At power-on, the internally-triggered burst mode is enabled.*

- Burst trigger source: Internal (default), External, Timer, or Manual.
- When the *Internal* (immediate) source is selected, the frequency at which the burst is generated is determined by the *burst period*.
- When the *External* source is selected, the waveform generator will accept a hardware trigger applied to the rear-panel *Ext Trig* connector. The waveform generator outputs the specified number of cycles each time *Ext Trig* receives a TTL pulse with the specified polarity. External trigger signals that occur during a burst are ignored.
- When the *Manual* source is selected, the waveform generator outputs one burst each time the front-panel  key is pressed or the *TRG command is issued.
- When the *External* or *Manual* trigger source is selected, the *burst count* and *burst phase* remain in effect but the *burst period* is ignored.
- When the *Timer* trigger source is selected, the instrument uses a 50% duty cycle trigger output.
- *Front-Panel Operation:* Press , the **Trigger Setup** softkey and then select the source by pressing the **Trg Src** softkey.

To specify whether the waveform generator triggers on the rising or falling edge of the signal on the *Ext Trig* connector, press the **Trigger Setup** softkey. Then select the desired edge direction with the **Slope** softkey.

Burst Mode

- *Remote Interface Operation:*

```
[TRIGger[1|2]:]TRIGger:SOURce
  {IMMediate|EXTernal|TIMer|BUS}
```

Use the following command to specify whether the waveform generator triggers on the rising or falling edge of the *Ext Trig* connector.

```
[TRIGger[1|2]:]TRIGger:SLOPe {POSitive|NEGative}
```

See “Triggering” on page 161 for more information on triggering.

Trigger Out Signal



A “trigger out” signal is provided on the rear-panel *Trig Out* connector (used with burst and sweep only). When enabled, a TTL-compatible pulse waveform with either a rising edge (default) or falling edge is output from the *Trig Out* connector at the beginning of the burst.

- When the *Internal* (immediate) trigger source is selected the waveform generator outputs a square waveform with a 50% duty cycle from the *Trig Out* connector at the beginning of the burst. The frequency of the waveform is equal to the specified *burst period*.
- When the *External* trigger source is selected, the waveform generator automatically disables the “trigger out” signal. The *Trig Out* connector cannot be used for both operations at the same time (an externally-triggered waveform uses the same connector to trigger the burst).
- When the *Manual* trigger source is selected, the waveform generator outputs a pulse (>1 μ s pulse width) from the *Trig Out* connector at the beginning of each burst.
- *Front-Panel Operation:* After enabling bursts, press  and the **Trig Out Setup** softkey. Then select the desired edge by pressing the **Trig Out** softkey.
- *Remote Interface Operation:*

```
OUTPut:TRIGger:SLOPe {POSitive|NEGative}
OUTPut:TRIGger {OFF|ON}
```

Triggering

Applies to sweep and burst only. You can issue triggers for sweeps or bursts using *internal* triggering, *external* triggering, *timer* triggering, or *manual* triggering.

- Internal or “automatic” triggering is enabled when you turn on the waveform generator. In this mode, the waveform generator outputs continuously when the sweep or burst mode is selected.
- External triggering uses the rear-panel *Ext Trig* connector to control the sweep or burst. The waveform generator initiates one sweep or outputs one burst each time *Ext Trig* receives a TTL pulse. You can select whether the waveform generator triggers on the rising or falling edge of the external trigger signal.
- Manual triggering initiates one sweep or outputs one burst each time you press  on the front-panel. Continue pressing this key to re-trigger the waveform generator.
- When you are sweeping a list,  moves the waveform to the next frequency in the list.
- The  key is disabled when in remote and when a function other than burst or sweep is currently selected.

Trigger Source Choices

Applies to sweep and burst only. You must specify the source from which the waveform generator will accept a trigger.

- Sweep and Burst trigger source: Immediate (default), External, Manual or Timer.
- The waveform generator will accept a manual trigger, a hardware trigger from the rear-panel *Ext Trig* connector, or continuously output sweeps or bursts using an internal trigger. You can also trigger bursts based on a timer. *At power-on, immediate trigger is selected.*

Triggering

- The trigger source setting is stored in *volatile* memory; the source is set to internal trigger (front panel) or immediate (remote interface) when power has been off or after a remote interface reset. (Provided that the Power On state is set to Factory.)
- *Front-Panel Operation:* After enabling sweeps or bursts, press  and select the desired source by pressing the **Trg Src** softkey.
- *Remote Interface Operation:*





```
TRIGger[1|2]:SOURce {IMMediate|EXTernal|TIMer|BUS}
```

The APPLy command automatically sets the source to *Immediate*.

Immediate Triggering In the internal trigger mode, the waveform generator continuously outputs the sweep or burst (as specified by the *sweep time* or *burst period*). This is the default trigger source for both front-panel and remote interface use.

- *Front-Panel Operation:* Press  and then press **Trg Src** and select **Immed**.
- *Remote Interface Operation:*

```
TRIGger:SOURce IMMediate
```

Manual Triggering In the manual trigger mode (front panel only), you can manually trigger the waveform generator by pressing the front-panel  key. The waveform generator initiates one sweep or outputs one burst for each time you press the key. The  key is illuminated when you are in the trigger menu and the waveform generator is waiting for a manual trigger. The  key blinks when the waveform generator is waiting for a manual trigger, but you are not in the trigger menu. The  key is disabled when the instrument is in remote.

External Triggering In the external trigger mode, the waveform generator will accept a hardware trigger applied to the rear-panel *Trig In* connector. The waveform generator initiates one sweep or outputs one burst each time *Ext Trig* receives a TTL pulse with the specified edge.

See also “Trigger Input Signal,” on the following page.

- *Front-Panel Operation:* The external trigger mode is like the manual trigger mode except that you apply the trigger to the *Ext Trig* connector. To select the external source, press  and then **Trg Src** and **Ext**.

To specify whether the waveform generator triggers on the rising or falling edge, press the **Trigger Setup** softkey and select the desired edge direction by pressing **Slope**.

- *Remote Interface Operation:*

```
TRIGger:SOURce EXTernal
```

Use the following command to specify whether the waveform generator triggers on the rising or falling edge.

```
TRIGger:SLOPe {POSitive|NEGative}
```

Triggering

Software (Bus) Triggering The bus trigger mode is available only from the remote interface. This mode is similar to the manual trigger mode from the front panel, but you trigger the waveform generator by sending a bus trigger command. The waveform generator initiates one sweep or outputs one burst each time a bus trigger command is received. The  key blinks when a bus trigger command is received.

- To select the bus trigger source, send the following command.

```
TRIGger:SOURce BUS
```

- To trigger the waveform generator from the remote interface (GPIB, USB, or LAN) when the *Bus* source selected, send the TRIG or *TRG (trigger) command. The front-panel  key is illuminated when the waveform generator is waiting for a bus trigger.

Timer Triggering The timer trigger mode issues triggers a fixed period apart.

- To select the bus trigger source, send the following command.

```
TRIGger:SOURce TIM
```

Trigger Input Signal

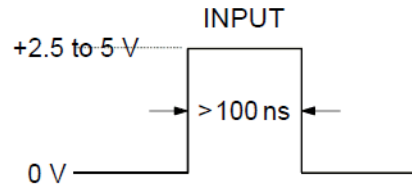
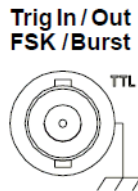

Rising edge shown.

This rear-panel connector is used in the following modes:

- *Triggered Sweep Mode:* To select the external source, press the **Trigger Setup** softkey and then select the **Source Ext** softkey or execute the `TRIG:SOUR EXT` command from the remote interface (sweep must be enabled). When the rising or falling edge (you specify which edge) of a TTL pulse is received on the *Ext Trig* connector, the waveform generator outputs a single sweep.
- *Externally-Modulated FSK Mode:* To enable the externally-modulated mode, press the **Source** softkey from the front-panel or execute the `FSK:SOUR EXT` command from the remote interface (FSK must be enabled). When a logic *low* level is present, the *carrier* frequency is output. When a logic *high* level is present, the *hop* frequency is output. The maximum external FSK rate is 100 kHz.
- *Triggered Burst Mode:* To select the external source, press the **Trigger Setup** softkey and then select the **Source Ext** softkey or execute the `TRIG:SOUR EXT` command from the remote interface (burst must be enabled). The waveform generator outputs a waveform with a specified number of cycles (*burst count*) each time a trigger is received from the specified trigger source.
- *External Gated Burst Mode:* To enable the gated mode, press the **Gated** softkey or execute `BURS:MODE GAT` from the remote interface with burst enabled. When the external gate signal is *true*, the waveform generator outputs a continuous waveform. When the external gate signal goes *false*, the current waveform cycle is completed and then the waveform generator stops while remaining at the voltage level corresponding to the starting burst phase. For noise, the output stops immediately when the gate signal goes false.

Triggering

Trigger Output Signal

A “trigger out” signal is provided on the rear-panel *Trig Out* connector (*used with sweep and burst only*). When enabled, a TTL-compatible square waveform with either a rising edge (default) or falling edge is output from the rear-panel *Trig Out* connector at the beginning of the sweep or burst.

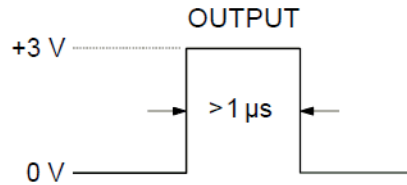

Rising edge shown.

- When the *Internal* (immediate) trigger source or *Timer* is selected, the waveform generator outputs a square waveform with a 50% duty cycle from the *Trig Out* connector at the beginning of the sweep or burst. The period of the waveform is equal to the specified *sweep time* or *burst period*.
- When the *External* trigger source is selected, the waveform generator automatically disables the “trigger out” signal. The *Trig Out* connector cannot be used for both operations at the same time (an externally-triggered waveform uses the same connector to trigger the sweep or burst).
- When the *Bus* (software) or manual trigger source is selected, the waveform generator outputs a pulse ($>1 \mu\text{s}$ pulse width) from the *Trig Out* connector at the beginning of each sweep or burst.
- *Front-Panel Operation:* After enabling sweeps or burst, press **Trig Out Setup**. Then select the desired edge by pressing **Trig Out**.
- *Remote Interface Operation:*

```
OUTPut:TRIGger:SLOPe {POSitive|NEGative}
OUTPut:TRIGger {OFF|ON}
```

System-Related Operations

This section gives information on topics such as instrument state storage, power-down recall, error conditions, self test, and front-panel display control. This information is not directly related to waveform generation but is an important part of operating the waveform generator.

Instrument State Storage

There are two ways you can store and retrieve instrument states in the Agilent 33500 Series. One way is to use named state files, using either the front panel or the SCPI commands `MMEMoRY:STORe:STATe` and `MMEMoRY:LOAD:STATe`. The second way is to save states to memory locations 1 through 4 with `*SAV`, to retrieve states from these locations with `*RCL`.

- If you choose to use `*SAV` and `*RCL`, you can use the special storage location “0” to store a fifth instrument state (you cannot store to this location from the front panel). However, note that location “0” is automatically overwritten when power is cycled (the instrument state previously stored will be overwritten).
- Regardless of which method you use, the state storage feature “remembers” the selected function (including arbitrary waveforms), frequency, amplitude, DC offset, duty cycle, symmetry, as well as any modulation parameters in use.
- When power is turned off, the function generator automatically stores its state in the special storage location “0”. You can configure the function generator to automatically recall the power-down state when power is restored. However, when shipped from the factory, the function generator is configured to automatically recall the factory default state at power-on.

- If you delete an arbitrary waveform from non-volatile memory after storing the instrument state, the waveform data is lost and the function generator will not output the waveform when the state is recalled. The built-in “exponential rise” waveform is output in place of the deleted waveform.
- An instrument reset does not affect the configurations stored in memory. Once a state is stored, it remains until it is overwritten or specifically deleted.
- *Front-Panel Operation:* Press  and then select the **Store/Recall** softkey. You can then perform several operations:

To save a state, press **Store State**, enter the desired name with the knob and arrows, and then press **Store State**. The state file will be automatically created with the .sta extension.

To recall a precious saved state file, press **Recall State**. Use the knob and arrows to browse to the desired file (note that the right arrow expands a folder). Then press **Select**.

To delete a stored state, select the **Delete State** softkey, use the browser to select the .sta file, and then press **Select**.

To configure the waveform generator to recall the factory default state at power-on, press  and then select the **Store/Recall** softkey. Then toggle the **Power On** softkey as necessary to select **Factory**. To configure the waveform generator to recall the power-down state when power is restored, toggle the **Power On** softkey as necessary to select **Last**. This will recall state “0,” as described above.

Remote Interface Operation: To configure the waveform generator to automatically recall the power-down state when power is restored, send the following command.

```
MEMory:STATe:RECall:AUTO ON
```

Error Conditions

A record of up to 20 command syntax or hardware errors can be stored in the waveform generator's error queue. *See the Agilent 33500 Series Programmer's Reference Help for a complete list of errors.*

- Errors are retrieved in first-in-first-out (FIFO) order. The first error returned is the first error that was stored. Errors are cleared as you read them. The waveform generator beeps once each time an error is generated (unless you have disabled the beeper).
- If more than 20 errors have occurred, the last error stored in the queue (the most recent error) is replaced with “*Queue overflow*”. No additional errors are stored until you remove errors from the queue. If no errors have occurred when you read the error queue, the waveform generator responds with “*No errors in queue*”.
- The error queue is cleared by the *CLS (clear status) command or when the power is cycled. The errors are also cleared when you read the error queue. The error queue *is not* cleared by an instrument reset (*RST command).
- *Front-Panel Operation:* Press System and **Help**, and then select the topic entitled “*View the remote command error queue*” (topic number 2). Then press the **Select** softkey to view the errors in the error queue.
- *Remote Interface Operation:*

SYSTem:ERRor? *Reads and clears one error from the error queue*

Errors have the following format (the error string may contain up to 255 characters).

-113, "Undefined header"

Beeper Control

Normally, the waveform generator will emit a tone when an error is generated from the front-panel or over the remote interface. You may want to disable the front-panel beeper for certain applications.

- The beeper state is stored in *non-volatile* memory and *does not* change when power has been off or after a remote interface reset. When shipped from the factory, the beeper is enabled.
- Turning off the beeper *does not* disable the key click generated when you press a front-panel key or turn the knob.
- *Front-Panel Operation:* Press , then **System Setup, User Settings** and **Beeper**.
- *Remote Interface Operation:*

```
SYSTem:BEEPer Issue a single beep immediately  
SYSTem:BEEPer:STATe {OFF|ON} Disable/enable beeper
```

Display Screen Saver

The front-panel display backlight will normally turn off and the screen will go blank after 8 hours of inactivity. For certain applications, you may want to disable the screen saver feature. *This feature is available from the front panel only.*

- The screen saver setting is stored in *non-volatile* memory and *does not* change when power has been off or after a remote interface reset. When shipped from the factory, the screen saver mode is enabled.
- *Front-Panel Operation:* Press , then **System Setup, User Settings, Display Options**, and **Scrn Svr**.

Display Brightness

To optimize the readability of the front-panel display, you can adjust the brightness setting. *This feature is available from the front panel only.*

- Display brightness: 10% to 100% (default).
- The contrast setting is stored in *non-volatile* memory and *does not* change when power has been off or after a remote interface reset.
- *Front-Panel Operation:* Press , then **System Setup**, **User Settings**, **Display Options**, and **Brightness**.

Date and Time

You can set the date and time on your instrument.

- *Front-Panel Operation:* Press , then **System Setup**, then **Date/Time**.
- *Remote Interface Operation:*

SYSTem:DATE <yyyy>, <mm>, <dd>

SYSTem:TIME <hh>, <mm>, <ss>

Manage Files

You can perform file management tasks, including copying, renaming, deleting, and creating new folders.

- *Front-Panel Operation:* Press **System**, then **System Setup**, then **Manage Files**.

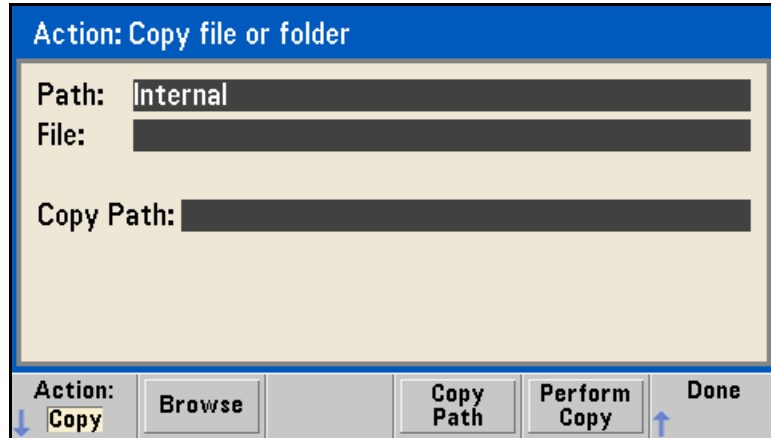

- You can copy, rename, or delete files or folders. Deleting a folder removes all of the files within the folder, so be sure that you want to delete all of the files within the folder.
- The most important softkey is the **Action** softkey, which allows you to specify what action you wish to perform. Once you have chosen the action that you wish to perform, press **Browse** to select the file to manage. Once you are completely prepared to execute the task, press the **Perform** softkey.
- *Remote Interface Operation:* (see MEMory and MMEMory subsystems in *Agilent 33500 Series Programmer's Reference Help*).

Self-Test



- A *power-on* self-test occurs automatically when you turn on the waveform generator. This limited test assures you that the waveform generator is operational.
- A *complete* self-test runs a series of tests and takes approximately 15 seconds to execute. If all tests pass, you can have high confidence that the waveform generator is fully operational.
- If the complete self-test is successful, “Self-Test Passed” is displayed on the front panel. If the self-test fails, “Self-Test Failed” is displayed and an error number is shown. Also, one or more errors are logged to the system error queue. See the *Agilent 33500 Series Service Guide* for instructions on returning the instrument to Agilent for service.
- *Front-Panel Operation:* Press , and then select **Instr Setup** and **Self Test**.
- *Remote Interface Operation:*

*TST?

The self-test returns “0” if the self-test passes or “1” if it fails. If the self-test fails, the instrument also generates one or more error message with additional information on why the test failed.

Display Control

For security reasons, or to speed up the rate at which the waveform generator can execute commands from the remote interface, you may want to turn off the front-panel display. From the remote interface, you can also display a message on the front panel.

- When disabled, the front-panel display is blanked (however, the display backlight remains enabled). Pressing any key will turn the screen back on.
- Sending a message to the front-panel display from the remote interface overrides the display state. This means that you can display a message even if the display is currently disabled.
- The display is automatically enabled when power is cycled, after an instrument reset (*RST command), or when you return to local (front panel) operation. Press the  key or execute the IEEE-488 GTL (*Go To Local*) command from the remote interface to return to the local state.
- The display state is saved when you store the instrument state using *SAV command. When you recall the instrument state using *RCL command, the front-panel display will return to the previous state.
- You can display a text message on the front panel by sending a command from the remote interface. You can use upper- or lower-case letters (A-Z), numbers (0-9), and any other character on a standard computer keyboard.
- *Front-Panel Operation:* Press , **System Setup, User Settings, Display Options, and Display Off.**

- *Remote Interface Operation:* The following command turns off the front-panel display.

```
DISP OFF
```

The following command displays a message on the front panel and turns on the display if currently disabled.

```
DISP:TEXT 'Test in Progress...'
```

To clear the message displayed on the front panel (without changing the display state), send the following command.

```
DISP:TEXT CLEAR
```

Number Format

The waveform generator can show numbers on the front-panel display with periods or commas for the decimal point and digits separator. *This feature is available from the front panel only.*

- The number format is stored in *non-volatile* memory and *does not* change when power has been off or after a remote interface reset. When shipped from the factory, a period is used for the decimal point and commas are used for the digits separator (e.g., 1.000,000,00 kHz).
- *Front-Panel Operation:* Press , **System Setup**, and **User Settings**. and then select **Number Format**.

Firmware Revision Query

You can query the waveform generator to determine which revision of firmware is currently installed. The revision code contains five numbers in the form “A.aa-B.bb-C.cc-DD-EE”.

- A.aa** = Firmware revision
- B.bb** = Front panel firmware revision
- C.cc** = Power supply controller firmware revision
- DD** = FPGA revision
- EE** = PCBA revision

- *Front-Panel Operation:* Press , then **Help** and **About**.
- *Remote Interface Operation:* Use the following command to read the waveform generator’s firmware revision numbers.

```
*IDN?
```

This command returns a string in the form:

```
Agilent Technologies,[Model Number],[10-char Serial Number],  
A.aa-B.bb-C.cc-DD-EE
```

SCPI Language Version Query

The waveform generator complies with the rules and conventions of the present version of SCPI (*Standard Commands for Programmable Instruments*). You can determine the SCPI version with which the instrument is in compliance by sending a query from the remote interface.

You cannot query the SCPI version from the front panel.

- *Remote Interface Operation:*

```
SYSTem:VERSion?
```

Returns a string in the form “YYYY.V”, where “YYYY” represents the year of the version, and “V” represents a version number for that year (e.g., 1999.0).

License Installation (for Option 002)

- The waveform generator includes has an optional feature (option 002) for extended waveform memory. Install the license for this option as follows:

- 1 Install the license file onto a USB drive and insert the USB drive into the instrument's front panel.**
- 2 Press , then System Setup, then Install License.**
- 3 Use the knob and arrows to select the file under External, then press Enter.**

Remote Interface Configuration

This section gives information on configuring the waveform generator for remote interface communication. For information on configuring the instrument from the front panel, see “To Configure the Remote Interface” starting on page 65. For information on the SCPI commands available to program the waveform generator over the remote interface, see the *Agilent 33500 Series Programmer’s Reference Help*.

The Agilent 33500 Series supports remote interface communication using a choice of three interfaces: GPIB (optional), USB, and LAN. All three interfaces are “live” at power up. This section describes some interface configuration parameters that you may need to set on your waveform generator.

- **GPIB Interface.** You need only set the GPIB address for the waveform generator and connect it to your PC using a GPIB cable.
- **USB Interface.** There is nothing to configure on your waveform generator. Just connect the waveform generator to the PC with a USB cable.
- **LAN Interface.** By default, DHCP is On, which may enable network communication over the LAN interface. You may need to set several configuration parameters as described in the LAN configuration sections that follow.

Connectivity Software and Product CDs

The Agilent 33500 Series is shipped with two CDs:

- **Agilent Automation-Ready CD:** This CD contains the *Agilent IO Libraries Suite* software, which must be installed to enable remote-interface operations. The CD auto-starts and provides information on installing the software. Refer to the *Agilent Technologies USB/LAN/GPIB Connectivity Guide*, which is provided on this CD-ROM, for additional background information.
- **Agilent 33500 Series Product-Reference CD:** This CD contains the 33500 Series instrument drivers, the *Agilent Intuilink Waveform Editor* software, the complete set of Agilent 33500 Series product manuals, and programming examples. The CD auto-starts and provides a Welcome page with instructions.

GPIB Configuration

Each device on the GPIB (IEEE-488) interface must have a unique address. You can set the waveform generator’s address to any value between 0 and 30. The address is set to “10” when the waveform generator is shipped from the factory. The GPIB address is displayed at power-on.

- The address is stored in *non-volatile* memory and *does not* change when power has been off or after a remote interface reset.
- Your computer’s GPIB interface card has its own address. Be sure to avoid using the computer’s address for any instrument on the interface bus.
- *Front-Panel Operation:* Press , and then select the **I/O Config** softkey and **GPIB Settings**. From this menu, you can set the GPIB address and turn GPIB on or off.

- *Remote Interface Operation:*

```

SYSTEM:COMMunicate:GPIB:ADDResS <address>
SYSTEM:COMMunicate:GPIB:ADDResS?
SYSTEM:COMMunicate:ENABle <state>,GPIB
SYSTEM:COMMunicate:ENABle? GPIB
    
```

LAN Configuration

The following sections describe the primary LAN configuration functions that you can set from the 33500 Series front-panel Utility menu. SCPI commands are listed where applicable. In addition, there are some LAN configuration functions that can be performed only by using the SCPI commands. For a complete listing of the LAN configuration commands, see the *Agilent 33500 Series Programmer’s Reference Help*.

Note: *Some LAN settings require you to cycle power on the instrument in order for them to be activated. The instrument will briefly display a message on the screen when this is the case, so be sure to watch the screen closely as you change LAN settings.*

Resetting the LAN You can clear the Web Interface password, turn DHCP on, and restart the LAN at any time with the Reset LAN feature:

- *Front panel operation:* Press  and press the **I/O Config** softkey. Then press **LAN Reset**. The message “Performing LAN Reset” is displayed while the LAN is reset.
- There is no SCPI command to reset the LAN.

DHCP On/Off (LAN) DHCP (Dynamic Host Configuration Protocol) is a protocol for automatically assigning a dynamic IP address to a device on a network. DHCP is typically the easiest way to configure your Agilent 33500 Series for remote communication using the LAN interface.

- Press **System** and press the **I/O Config** softkey. Then press **LAN Settings** and **Modify Settings**. Finally, toggle the first softkey to read **DHCP** to use DHCP to automatically assign an IP address.
- The DHCP setting is stored in *non-volatile* memory and does not change when power has been off or after a remote interface reset.
- *Front panel operation:* Press **System** and press the **I/O Config** softkey. Then press **LAN Settings** and **Modify Settings**. Finally, toggle the first softkey to read **DHCP** to use DHCP to automatically assign an IP address.
- You can turn DHCP on or off with the command:
- `SYSTEM:COMMunicate:LAN:DHCP <state>`

Note: *If you want to set an IP address, Subnet Mask, or Default Gateway manually, you must turn off DHCP. Then change the IP setup as described in the following sections.*

IP Address (LAN) You can enter a static IP address for the 33500 Series as a four-byte integer expressed in *dot notation* (“nnn.nnn.nnn.nnn”, where “nnn” in each case is a byte value from 0 to 255). Each byte is expressed as a decimal value, with no leading zeros (for example, 169.254.2.20).

- If DHCP is on, it will attempt to assign an IP address to the instrument. If it fails, AutoIP will attempt to assign an IP address to the instrument.
- Contact your network administrator for a valid IP address to use for your waveform generator.
- Enter the IP address using the numeric keypad or knob.
- The IP address is stored in *non-volatile* memory and does not change when power has been off or after a remote interface reset.
- *Front panel operation:* Press  and press the **I/O Config** softkey. Then press **LAN Settings** and **Modify Settings**. Finally, toggle the first softkey to read **Manual** and press **IP Address** to enter a new IP address.
- Enter the desired address.
- *Remote interface operation:*
SYSTEM:COMMunicate:LAN:IPADdress <address>
SYSTEM:COMMunicate:LAN:IPADdress?

More About Dot Notation: *Dot-notation addresses (“nnn.nnn.nnn.nnn” where “nnn” is a byte value) must be expressed with care, as most web software on the PC will interpret byte values with leading zeros as octal numbers. For example, “192.168.020.011” is actually equivalent to decimal “192.168.16.9” not “192.168.20.11” because “.020” is interpreted as “16” expressed in octal, and “.011” as “9”. To avoid confusion, use only decimal expressions of byte values (0 to 255), with no leading zeros.*

For example, the 33500 Series assumes that all dot-notation addresses are expressed as decimal byte values and strips all leading zeros from these byte values. Thus, attempting to set an IP address of “192.168.020.011” will become “192.168.20.11” (a purely decimal expression). Be sure to enter the exact expression, “192.168.20.11”, in your PC web software to address the instrument. Do not use “192.168.020.011” - the PC will interpret this address differently due to the leading zeros.

Subnet Mask (LAN) Subnetting allows the network administrator to divide a network into smaller networks to simplify administration and to minimize network traffic. The subnet mask indicates the portion of the host address to be used to indicate the subnet.

- Contact your network administrator to find out whether subnetting is being used, and for the correct subnet mask.
- Enter the subnet mask using the numeric keypad or knob.
- The subnet mask is stored in *non-volatile* memory and does not change when power has been off or after a remote interface reset.
- Press  and press the **I/O Config** softkey. Then press **LAN Settings** and **Modify Settings**. Finally, toggle the first softkey to read **Manual** and press **Subnet Mask** to enter a new subnet mask. Enter the appropriate mask (for example: 255.255.0.0).
- *Remote interface operation:*
- SYSTem:COMMunicate:LAN:SMASK "<mask>"

Default Gateway (LAN) A gateway is a network device that provides a connection between networks. The default gateway setting is the IP address of such a device.

- You need not set a gateway address if DHCP or Auto IP is in use.
- Contact your network administrator to find out whether a gateway is being used, and for the address.
- Enter the gateway address using the numeric keypad or knob.
- The gateway address is stored in *non-volatile* memory and does not change when power has been off or after a remote interface reset.
- *Front panel operation:* Press  and press the **I/O Config** softkey. Then press **LAN Settings** and **Modify Settings**. Finally, toggle the first softkey to read **Manual** and press **More** and **Gateway** to enter a new gateway. Then set the appropriate gateway address.
- *Remote Interface Operation:*

SYSTem:COMMunicate:LAN:GATeway "<address>"

Host Name (LAN) A host name is the host portion of the domain name, which is translated into an IP address.

- The instrument is assigned a unique hostname at the factory, but you may wish to change that name. However, the name must be unique on the LAN.
- Enter the host name using the knob and cursor keys. Each character in the name can be an upper or lower case letter, a numeric digit, or a dash (“-”).
 - Use the knob to select each character.
 - Use the cursor key to move to the next character.
 - You can use the keypad for numbers, but the host name cannot start with a number.
- The host name is stored in *non-volatile* memory and does not change when power has been off or after a remote interface reset.
- *Front panel operation:* Press  and press the **I/O Config** softkey. Then press **LAN Settings** and **Modify Settings**. Finally, press **Host Name** to enter a new host name.
- *Remote Interface Operation:*
- `SYSTEM:COMMunicate:LAN:HOSTname "<name>"`

Domain Name (LAN) A domain name is a registered name on the Internet, which is translated into an IP address.

- *Front panel operation:* There is no way to set the domain name from the front panel.
- There is no SCPI command to set a domain name.

DNS Server (LAN) DNS (Domain Name Service) is an Internet service that translates Domain names into IP addresses. The DNS server address is the IP address of a server that performs this service.

- Normally, DHCP discovers the DNS address information, so you only need to change this if DHCP is not functional or not in use.
- Contact your network administrator to find out whether DNS is being used, and for the correct DNS server address.
- Enter the address using the numeric keypad or knob.
- The DNS server address is stored in *non-volatile* memory and does not change when power has been off or after a remote interface reset.
- *Front panel operation:* Press  and press the **I/O Config** softkey. Then press **LAN Settings** and **Modify Settings**. Finally, toggle the first softkey to read **Manual** and press **More** and **Primary DNS** or **Second DNS** to enter a DNS address.
- *Remote Interface Operation:*
- `SYSTEM:COMMunicate:LAN:DNS [1 | 2] "<address>"`

Current Configuration (LAN) Select the Currently Active Settings display to view the MAC address and current LAN configuration.

- *Front panel operation:* Press  and press **I/O Config** and **LAN Settings**.
- There is no SCPI command to display the configuration screen.

Note: *This display reflects only the settings that are **currently active**. Also, this display is **static**. It does not update information for events that have occurred after the information is displayed. For example, if DHCP assigns an IP address while the display is open, you will not see the new IP address.*

If the instrument goes into remote, all LAN changes will be canceled, and the display will go to a different screen. Re-selecting the LAN Settings page will display the new settings if a LAN restart took place.

Additional SCPI Configuration Commands (LAN) There are some additional LAN configuration commands, not covered here, that are covered in the *Agilent 33500 Series Programmer's Reference Help*.

Agilent 33500 Series Web Interface

The Agilent 33500 Series provides a web interface resident in the instrument. You can use this interface over the LAN to view and modify the instrument's I/O configuration. Also, a remote front panel interface is provided, which allows you to control the instrument over the network.

To access and use the web interface:

1. Ensure that your PC includes Microsoft Internet Explorer version 6.0 or later and Java Virtual Machine (JVM).
2. Establish LAN interface connectivity from your PC to the 33500 Series.
3. Open your PC's Internet Explorer.
4. To launch the web interface enter the IP address of the *instrument*, or its fully qualified host name, in the browser address field.
5. Follow the directions in the web interface's online help.

USB Configuration

There are no USB configuration parameters to configure. You can retrieve the USB ID string (set by the manufacturer) by using the Show USB Id feature:

- *Front panel operation:* Press  and press the **I/O Config** softkey. Select **USB Settings** and **Show USB Id**. The USB string appears on the screen, and the longest string of digits is the instrument's serial number.
- There is no SCPI command to display the USB ID.

External Timebase Reference

The external Timebase Reference, which provides rear panel connectors (**10 MHz In** and **10 MHz Out**) and circuitry to allow synchronization between multiple Agilent 33500 Series waveform generators or to an external 10 MHz clock signal. You can also set the phase offset of the output waveform from the front panel or over the remote interface.

To align the phase of two Series 33500 instruments, you can use a dual-channel oscilloscope to compare the output signals:

1. Connect two 33500 Series instruments, with **10 MHz Out** connected to **10 MHz In**. The instrument with the more precise timebase should be used as the source of the 10 MHz reference out.

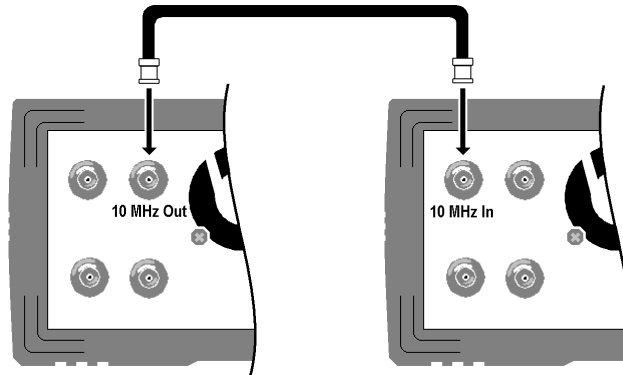

2. Connect the outputs of the waveform generators to the scope channel inputs:

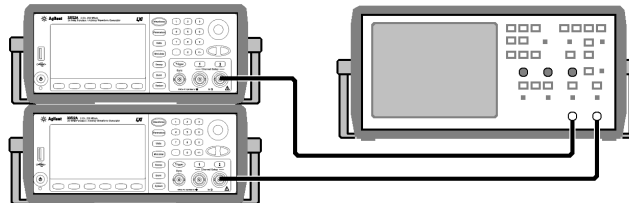

3. Set the same frequency on both waveform generators. The scope should show the signals to be in sync with regard frequency, but not phase. (A square wave works well to show the phase difference.)

- If any of the waveform generators are multichannel (33522A), you should phase sync the two channels to each other. This operation will also synchronize each channel's modulating waveforms to the carrier.

Front panel operation: Press **Channel** or **1** or **2**. Then press **Parameters**, **Phase**, and **Sync Internal**.

Remote Interface Operation:

```
[SOURce[1|2]:] PHASe:SYNChronize
```

- Leaving the phase setting at its default (zero) on the first waveform generator, use the **Adjust Phase** feature to adjust the phase of the second waveform generator to align the output signals:

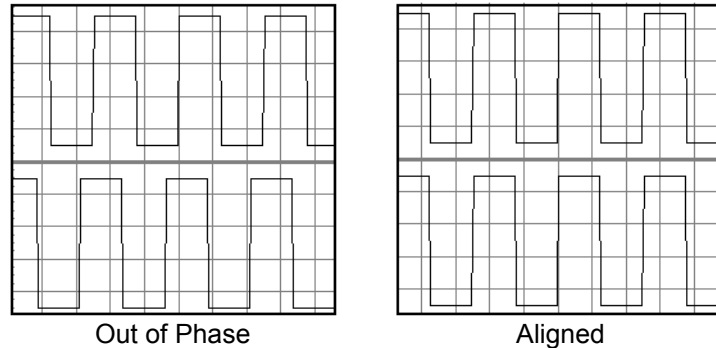

You can use the **Set 0 Phase** feature to set a new zero-phase reference point with the two waveform generators now aligned.

- Front-Panel Operation:* Press **Channel** or **1** or **2**. Then press **Parameters**, **Phase**, and set the phase angle using the numeric keypad or knob. Once aligned, set the 0 phase.
- Remote Interface Operation:* Use the following command to set the phase offset (the query returns the currently set offset):

```
[SOURce[1|2]:] PHASe {<angle>|MINimum|MAXimum}  
[SOURce[1|2]:] PHASe? [MINimum|MAXimum]
```

- The following command sets a new zero-phase reference point:

```
[SOURce[1|2]:] PHASe:REFerence
```

See Application Note 1426: *“How to Connect Two or More Signal Generators to Create a Multi-Channel Waveform Generator”* provides additional information on this subject.

Calibration Overview

This section gives a brief introduction to the calibration features of the waveform generator. For a more detailed discussion of the calibration procedures, see chapter 4 in the *Agilent 33500 Series Service Guide*.

Calibration Security

This feature allows you to enter a security code to prevent accidental or unauthorized calibrations of the waveform generator. When you first receive your waveform generator, it is secured. Before you can perform a calibration, you must unsecure the waveform generator by entering the correct security code.

If you forget your security code, see the *Agilent 33500 Series Service Guide* for more information.

- The security code is set to “AT33520A” when the waveform generator is shipped from the factory. The security code is stored in *non-volatile* memory and *does not* change when power has been off or after a remote interface reset.
- The security code may contain up to 12 alphanumeric characters. The first character must be a letter, but the remaining characters can be letters, numbers, or an underscore (“_”). You do not have to use all 12 characters but the first character must always be a letter.

To Unsecure for Calibration You can unsecure the waveform generator either from the front panel or over the remote interface. The waveform generator is secured when shipped from the factory and the security code is set to “AT33520”.

- Once you enter a security code, that code must be used for both front-panel and remote operation. For example, if you secure the waveform generator from the front panel, you must use that same code to unsecure it from the remote interface.
- *Front-Panel Operation:* Press  and select **Calibrate**. Then enter the security code with the knob and numeric keypad and select **Unlock Cal**.
- *Remote Interface Operation:* To unsecure the waveform generator, send the following command with the correct security code.

```
CAL:SECURE:STATE OFF,AT33520A
```

To Secure Against Calibration You can secure the waveform generator either from the front panel or over the remote interface. The waveform generator is secured when shipped from the factory and the security code is set to “AT33520A”.

- Once you enter a security code, that code must be used for both front-panel and remote operation. For example, if you secure the waveform generator from the front panel, you must use that same code to unsecure it from the remote interface.
- *Front-Panel Operation:* Press  and then select **Calibrate**.
- *Remote Interface Operation:* To secure the waveform generator, send the following command with the correct security code.

```
CAL:SECURE:STATE ON,NEWCALCODE
```

Calibration Overview

To Change the Security Code To change the security code, you must first unsecure the waveform generator, and then enter a new code. Make sure you have read the security code rules described on page 190 before attempting to change the security code.

- *Front-Panel Operation:* To change the security code, unsecure the waveform generator using the old security code. Then press , **Calibrate** and **Secure Code**. Changing the code from the front panel also changes the security code as seen from the remote interface.
- *Remote Interface Operation:* To change the security code, you must first unsecure the waveform generator using the old security code. Then enter the new code as shown below.

```
CAL:SECURE:STATE OFF, AT33520A    Unsecure with old code
CAL:SECURE:CODE NEWCALCODE       Enter new code
```

Calibration Count

You can query the waveform generator to determine how many calibrations have been performed. Your waveform generator was calibrated before it left the factory. When you receive your waveform generator, be sure to read the count to determine its initial value.

- The calibration count is stored in *non-volatile* memory and *does not* change when power has been off or after a remote interface reset.
- The calibration count increments up to a maximum of more than 4 billion ($2^{32}-1$). Since the value increments by one for each calibration point that stores a value, a complete calibration may increase the value by many counts.
- *Front-Panel Operation:* Press  and **Calibrate**.
- *Remote Interface Operation:*

```
CAL:COUNT?
```

Calibration Message

The waveform generator allows you to store one message in calibration memory in the mainframe. For example, you can store such information as the date when the last calibration was performed, the date when the next calibration is due, the waveform generator's serial number, or the name and phone number of the person to contact for a new calibration.

- You can record a calibration message *only* from the remote interface and *only* when the waveform generator is unsecured. You can read the message from either the front-panel or over the remote interface. You can *read* the calibration message whether the waveform generator is secured or unsecured.
- The calibration message may contain up to 40 characters (additional characters are truncated).
- Storing a calibration message will overwrite any message previously stored in memory.
- The calibration message is stored in *non-volatile* memory and *does not* change when power has been off or after a remote interface reset.
- *Front-Panel Operation:* Press  and **Calibrate**.
- *Remote Interface Operation:* To store the calibration message, send the following command, including any desired string within quotation marks (“”).

```
CAL:STR "Cal Due: 01 August 2011"
```

Embedded Waveform Editor

The Agilent 33500 Series includes an embedded waveform editor that allows you to create and edit arbitrary waveforms. You can create these waveforms by editing voltage values directly or by using any combination of up to 11 different kinds of standard waveforms.

The embedded waveform editor is described in the following sections:

“Standard Waveforms” on page 194

“Basic Waveform Editing” on page 198

“Advanced Edit” on page 202

“Advanced Math” on page 206

“Utility Menu” on page 213

Standard Waveforms

The embedded waveform editor includes the following 11 waveforms:

Sine

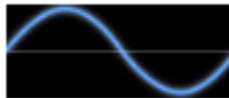

A basic sine wave:

$$y = \sin(x)$$

Square



A basic square wave that switches between two voltage levels

Ramp





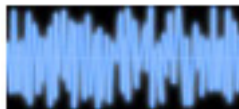

A waveform with linearly rising or falling voltage

Noise

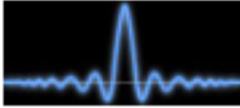

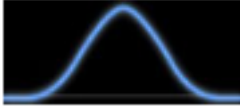
Random noise

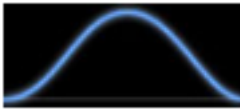
DC		A simple DC voltage
Sinc		The waveform function: $y = \sin(x)/x$
D-Lorentz		The derivative of the Lorentz function. The Lorentz function is $y = 1/(x^2+1)$. The D-Lorentz function, therefore is $y = -2x/(x^2+1)^2$
Gaussian		A waveform representing a gaussian bell curve
Expo Fall		An exponential decay: $y = e^{-kx}$
Expo Rise		An exponential rise: $y = 1 - e^{-kx}$
Haversine		The haversine function: $y = [1 - \cos(x)]/2$

When you select a waveform, the instrument displays a screen that allows you to specify the waveform's parameters. These parameters include:

Amplitude	The height of the waveform peak above 0 V when the waveform has 0 offset. Specified in Volts, from 10 μ V to 10 V (default 1).
Offset	The distance that the entire waveform is shifted up (positive value) or down (negative value) relative to 0 V. Specified in Volts, from -10 to 10 (default 0).
The Amplitude plus the Offset must be between -10 V and 10 V.	
Phase	The number of degrees that the waveform is advanced (positive value) or retarded (negative value) from 0 degrees. Specified in degrees from -360 to 360 (default 0).
Cycles	The number of complete output cycles that the waveform includes. Specified as a positive integer, and limited by the fact that each cycle must have at least 8 points.
Points	The number of points that the waveform includes. Specified as an integer from 8 to 1,000,000 (default 100). Option 002, supports up to 16,000,000 points.
Because a cycle must have at least 8 waveform points, the number of points divided by the number of cycles must be greater than or equal to 8.	
Half Width (D-Lorentz only)	A value that controls the waveform width; larger values make wider curves. Specified as an integer from 1 to the total number of data points in one cycle (default 10).
Fall Factor (Expo Fall only)	A number that controls how fast the waveform falls. Specified as a decimal number from -99 to 99 (default -5).
Rise Factor (Expo Rise only)	A number that controls how fast the waveform rises. Specified as a decimal number from -99 to 99 (default -5).

Full Width (Gaussian only)	The width of the gaussian bell curve between the points on the curve that are exactly one-half the bell curve's height, also called full-width half maximum. Specified as an integer from 1 to the number of data points in one cycle (default 10).
Symmetry (Ramp only)	The percentage of time (per cycle period) that the ramp is rising. Specified as a decimal number from 0 to 100 (default 100).
Zero Crossing (Sinc only)	The number of times the waveform crosses the horizontal axis on one side of the waveform. Specified as an integer from 0 to 100 (default 100).
Duty Cycle (Square only)	The percentage of the time (per cycle period) that the waveform voltage is high. Specified as a percentage from 0 to 100 (default 10).

Basic Waveform Editing

When you start the embedded waveform editor (press **Waveforms** and **Arb**, then **Arbs**, **Edit New**, and **Start Editor**), the opening screen appears. (Note that the same menu that contains the **Edit New** softkey also contains an **Import CSV** softkey. You can use this to import ASCII files from oscilloscopes and other common instruments.)

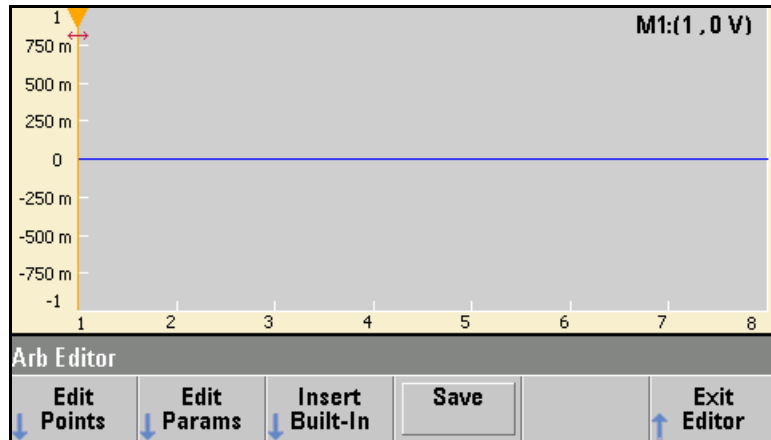

Edit Points allows you to edit the voltage values of individual points in the waveform. You can also insert and remove points in the waveform, and you can access the Advanced Edit features, which are described below.

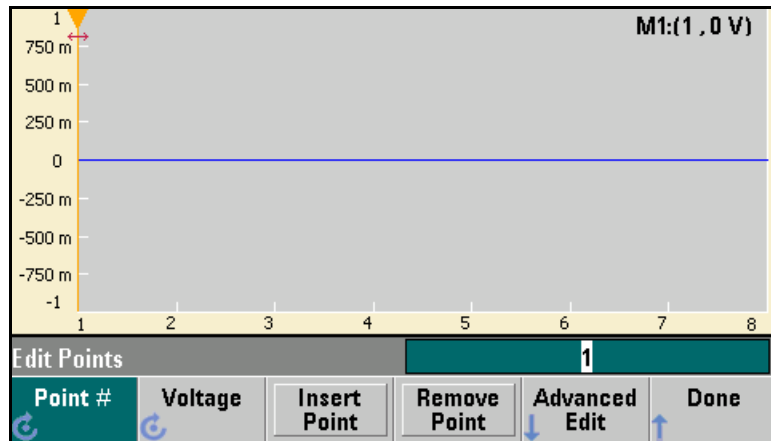

Edit Params allows you to set the waveform's sample rate, which is the rate (in points per second) in which the waveform is played. You can specify this value as a rate or as a period. If you change one, the other will recalculate based on the number of points in the waveform. This feature also allows you to specify whether the waveform is labeled with units of time or points along the horizontal axis.

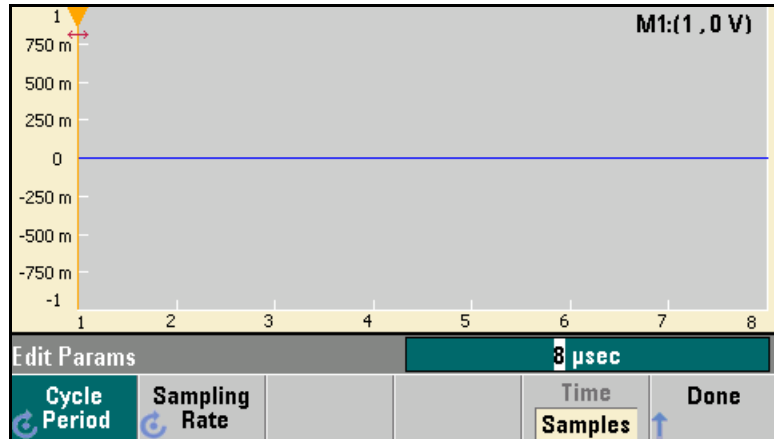

Insert Built-In allows you to insert one of 11 pre-defined waveforms into the current waveform.

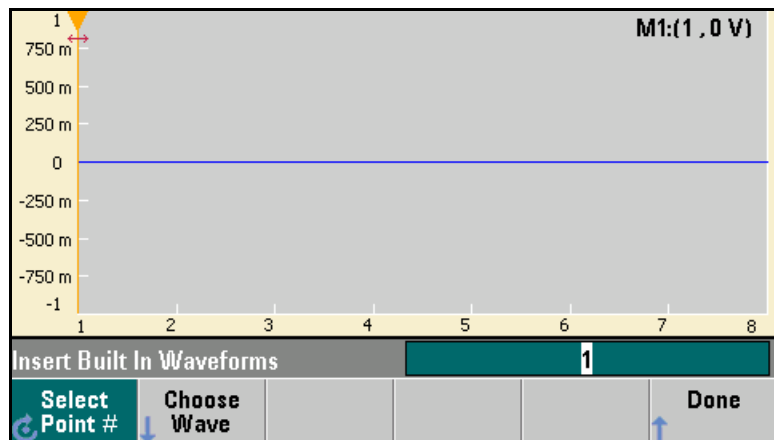

Select Point # allows you to specify where the waveform is to be inserted, and the **Choose Wave** softkey allows you to specify which one of the 11 waveform types is to be inserted.

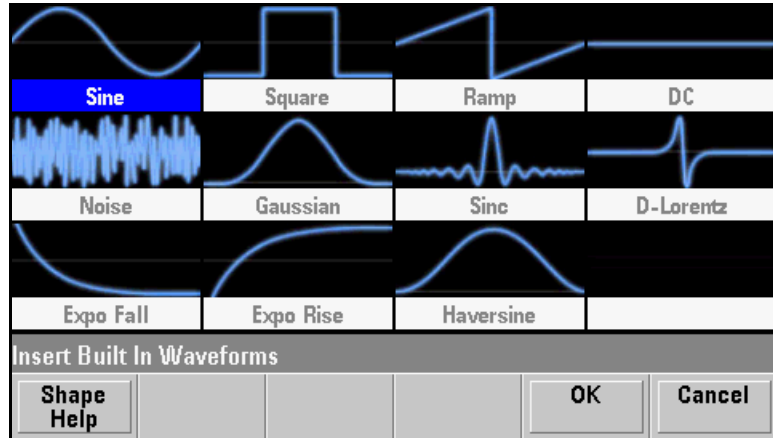

Once you have used the arrow keys to select the waveform to insert and pressed **OK**, the instrument displays the parameters for the waveform to be inserted. Specify the parameters and press **OK**.

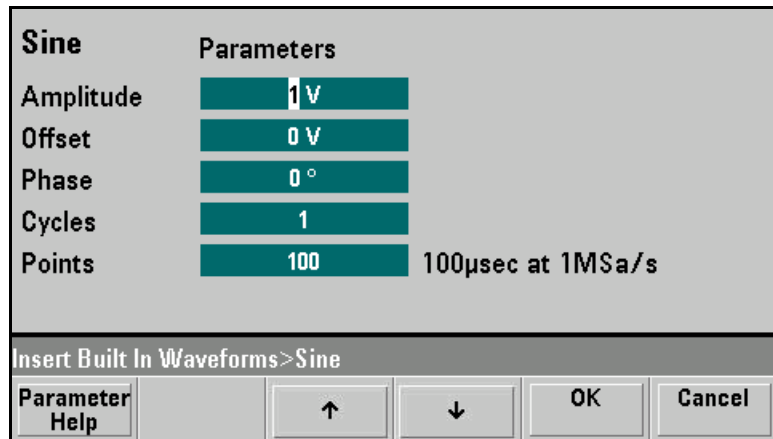

Save allows you to save the current waveform at its current location in the instrument's internal memory.

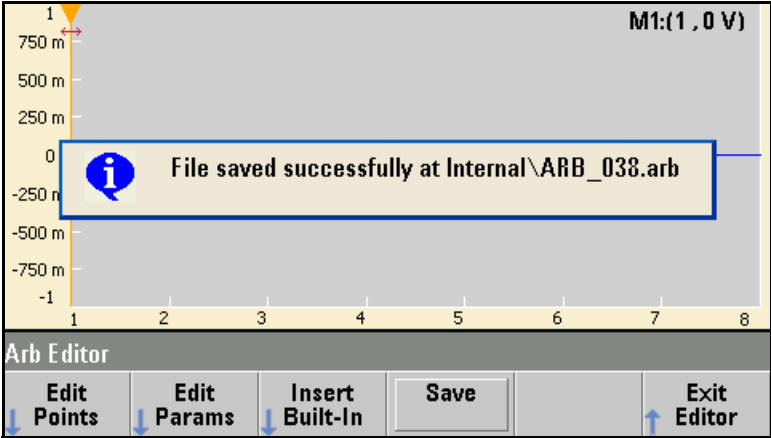

3

Exit Editor closes the embedded waveform editor and resumes normal front panel operation.

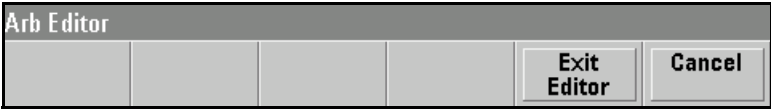

If you have unsaved changes, the instrument produces a warning message and gives you the option of staying in the embedded waveform editor.

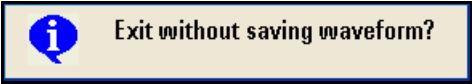

Advanced Edit

As described above, the **Edit Points** menu includes an **Advanced Edit** softkey. This softkey allows you to cut, copy and paste portions of the waveform, edit waveform points in a table, and perform mathematical operations on the waveform.

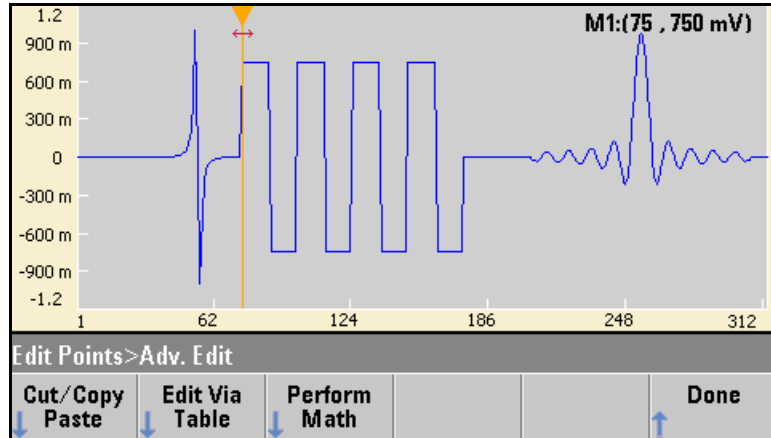

Cut/Copy/Paste allows you to define a range of the waveform between two markers and then cut or copy the waveform points defined by the markers. Once you have cut or copied the range, you can paste it as many times as desired by using the **Paste** softkey.



Paste Location allows you to paste a range at the start of the waveform, the end of the waveform, or any point within the waveform.

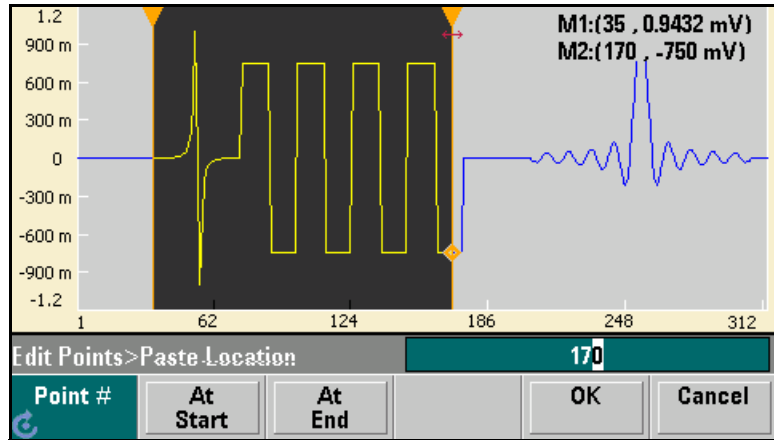

3

Edit Via Table allows you to edit the voltage values of individual points in a table. You can use the knob to scroll through the table, or you can use the **Point #** softkey to directly select any particular point. You can also insert or remove waveform points.

Point No. (Max 312)	Voltage Value (Volts)
1	0.00000
2	0.00000
3	0.00000
4	0.00000
5	0.00006
6	0.00006
7	0.00007
8	0.00007

Below the table is a dialog box titled 'Edit Points > Table' with a 'Point #' field set to 1. Below the dialog box are buttons for 'Point #', 'Voltage', 'Insert Point', 'Remove Point', and 'Done'.

Perform Math allows you to use markers to specify a range of the waveform. You can then add, subtract, or multiply the voltage values in that range by the voltage values in another waveform.

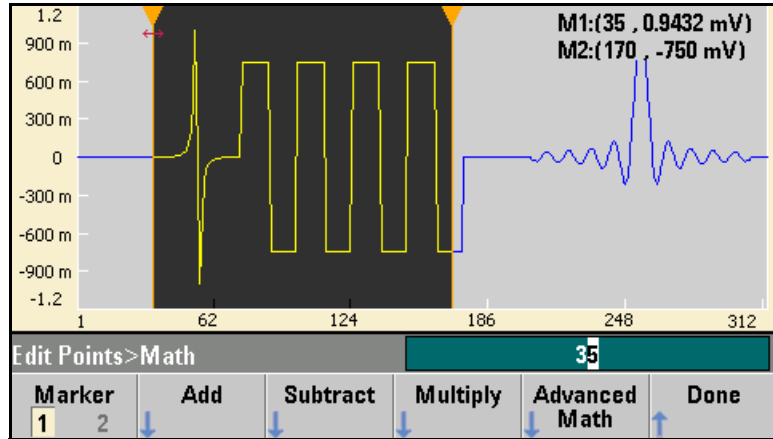

Once you have pressed **Add**, **Subtract**, or **Multiply**, the instrument displays a list of waveforms. Pick the waveform and press **OK**.

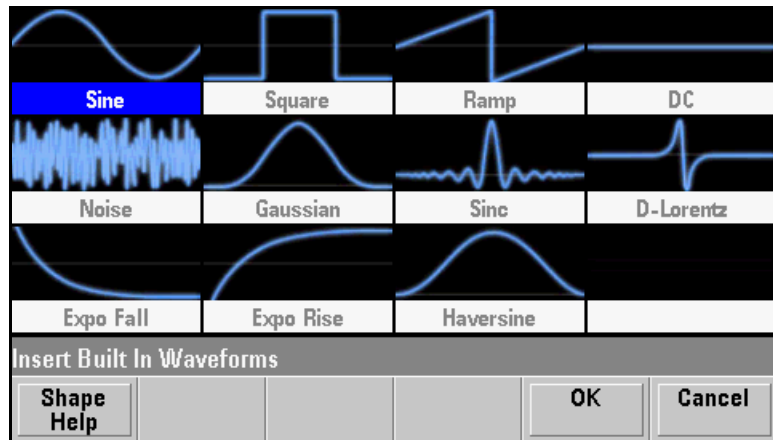

When you press **OK**, the instrument displays a list of parameters that you can use to specify the waveform. You can also use the **From Point** and **To Point** parameters to specify the range of points on which to perform the mathematical operation.

D-Lorentz	Parameters	Modify existing waveform
Amplitude	1 V	From Point 35
Offset	0 V	To Point 170
Phase	0 °	
Cycles	1	
Half Width	10	

Edit Points>Add>Built In Waveform>D-Lorentz

Parameter Help		↑	↓	OK	Cancel
----------------	--	---	---	----	--------



Advanced Math

Advanced Math allows you to perform several different types of operations on the waveform. To open **Advanced Math** from the embedded waveform editor, press **Edit Points**, **Advanced Edit**, **Perform Math**, and **Advanced Math**.

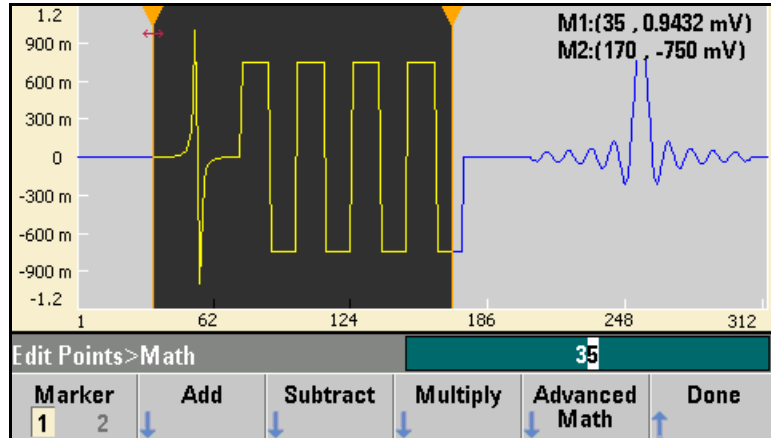

The Advanced Math menu will open with the following screen. Each of the operations shown below will be described below, using images taken before and after each operation to demonstrate the operations' effects.

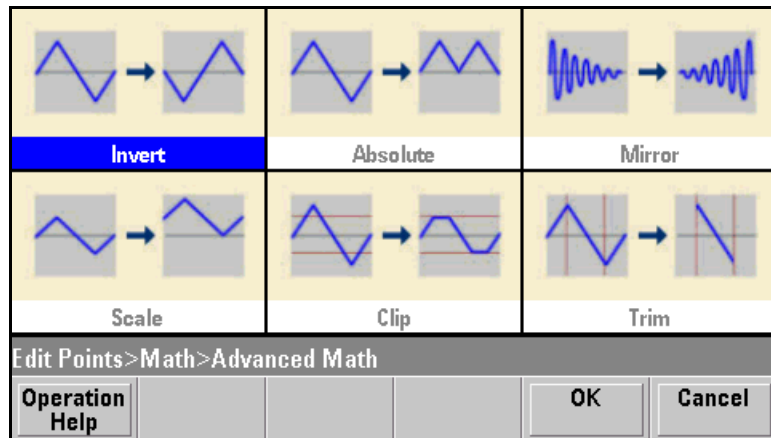

Invert reflects the waveform across the horizontal axis.

Image Before Operation

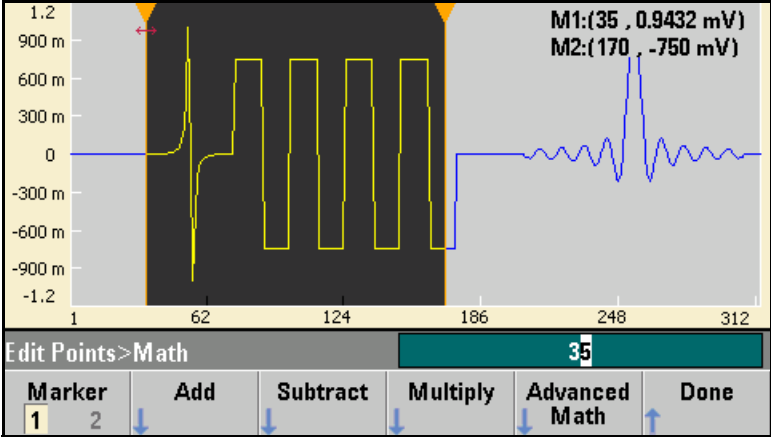

3

Image After Operation

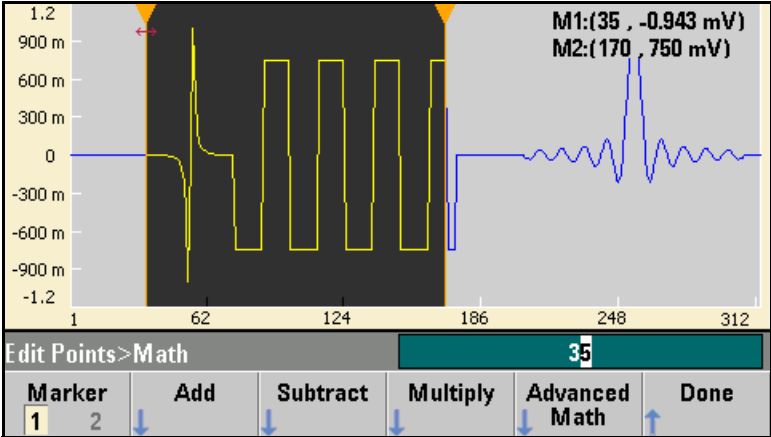

Absolute replaces all negative waveform values with their positive equivalents

Image Before Operation

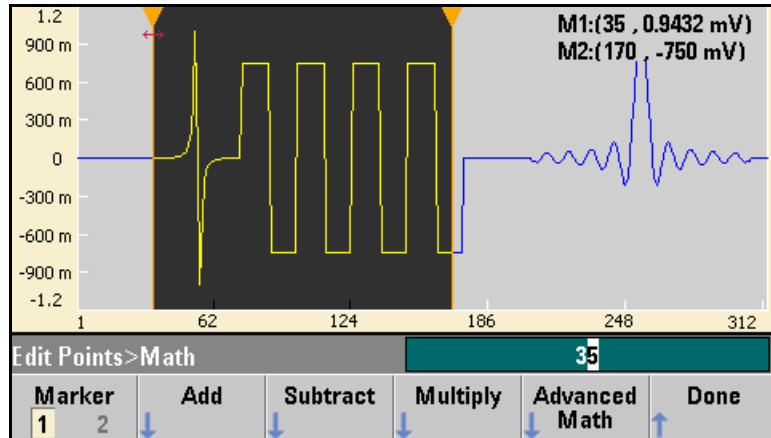
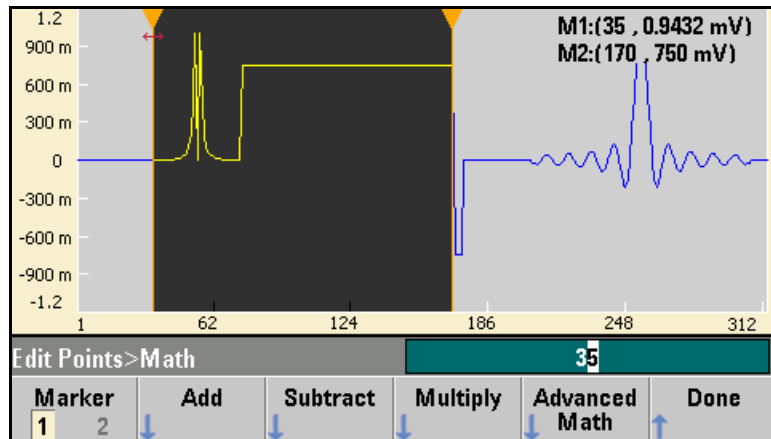
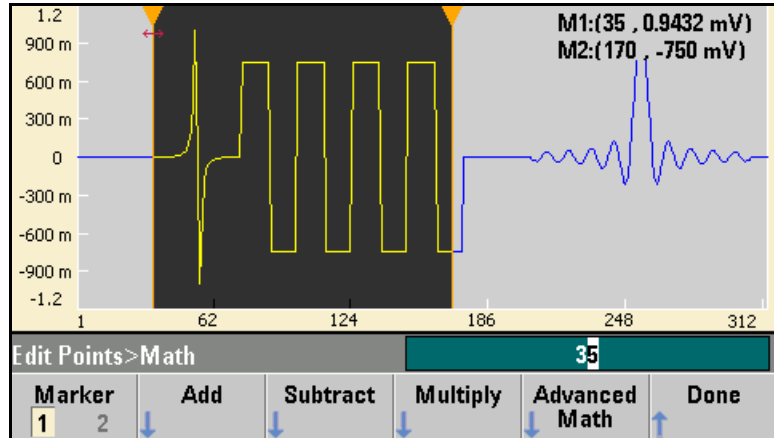

Image After Operation



Mirror reverses order of the points in the range.

Image Before Operation



3

Image After Operation

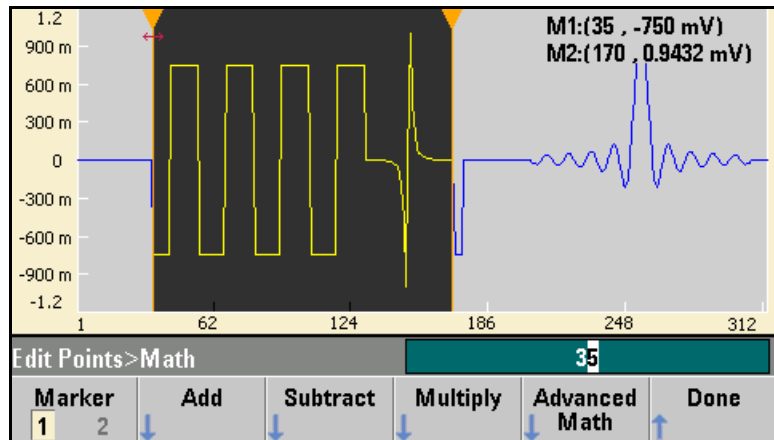

Scale allows you to use amplitude and offset to scale the waveform between the points. In this example, the amplitude scale was set to 180% and the offset scale was set to 1 V.

Image Before Operation

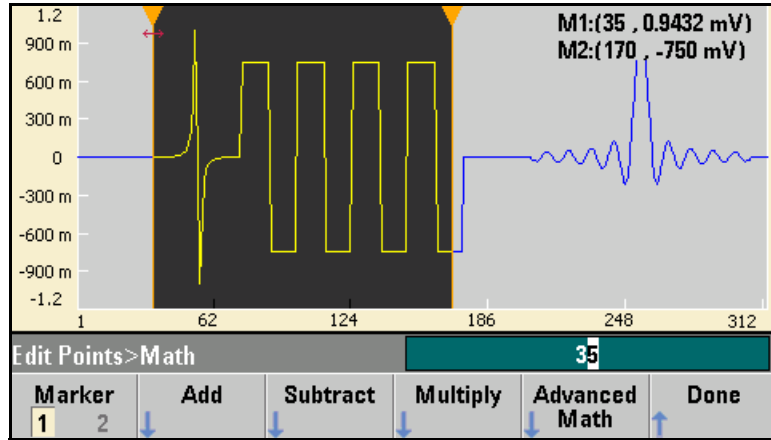
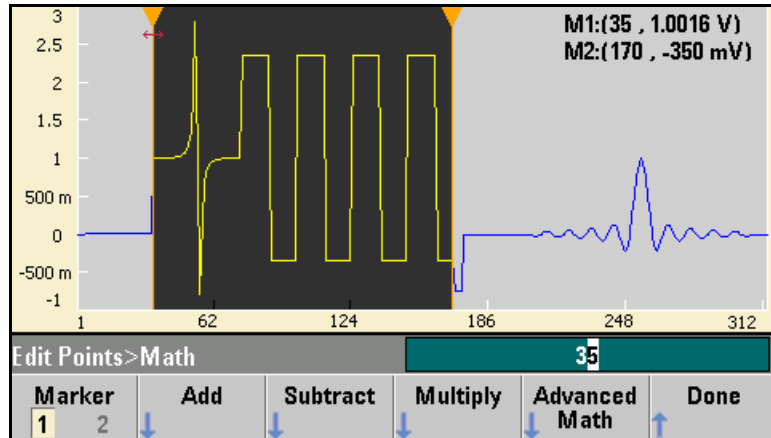
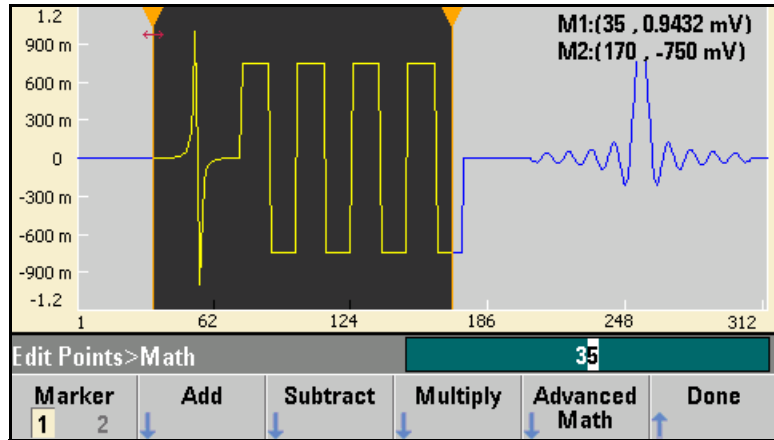

Image After Operation



Clip allows you to specify upper and lower limits on the waveform and changes voltage values outside those limits to be equal to the limits. In this example, the waveform was clipped to stay within the -400 mV lower limit and the 700 mV upper limit.

Image Before Operation



3

Image After Operation

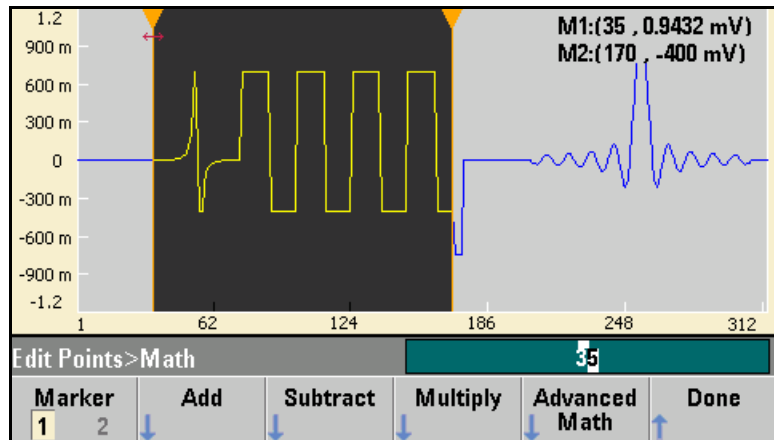

Trim allows you to use markers to “crop” the waveform so that only the points defined by the marker range remain in the waveform.

Image Before Operation

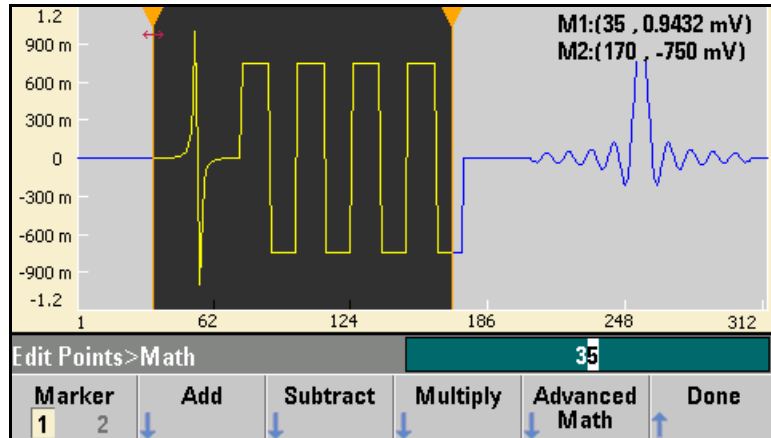
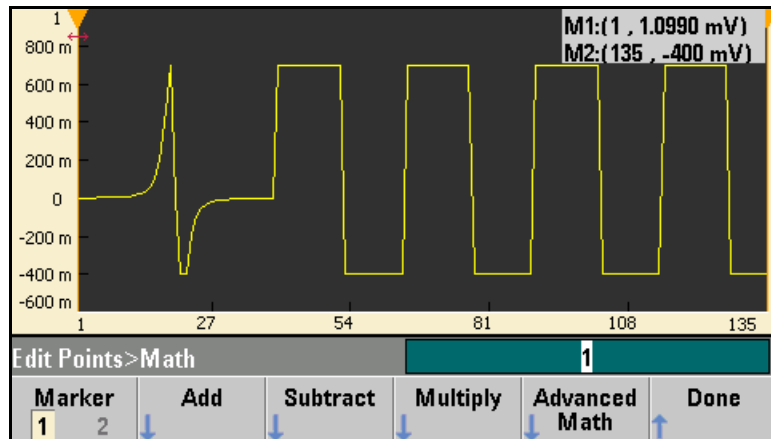
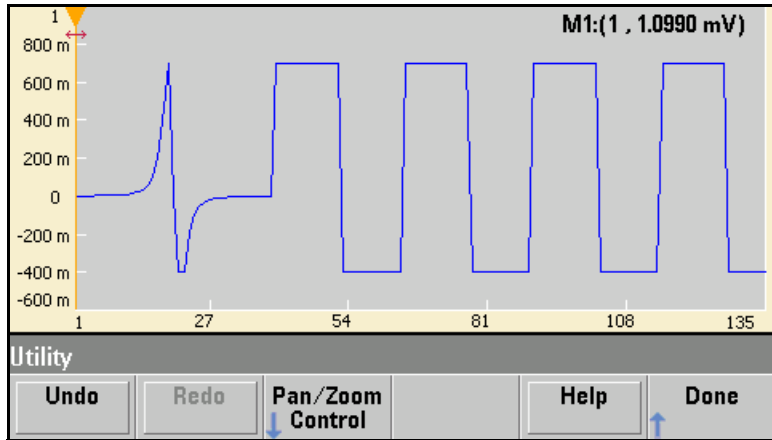

Image After Operation



Utility Menu

You can access several utility features by pressing **System** from within the embedded waveform editor.



3

Undo allows you to undo recent operations. The number of operations depends on the amount of available memory and the size of the undo operation.

Redo allows you to redo “undone” tasks, subject to the same limitations of memory and operation size.

Pan/Zoom Control allows you to zoom in either horizontally or vertically, using a zoom factor specified as a percentage. You can also pan (move the image) either horizontally or vertically in order to view a particular area of the waveform. Pan horizontally by specifying a point, and pan vertically by specifying a voltage.

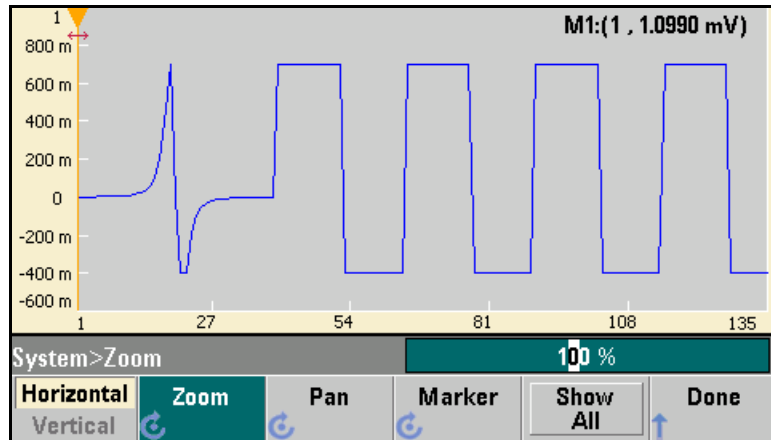

Show All resets the horizontal and vertical scale to display the entire waveform.

Factory Default Settings

The table on the following page summarizes the factory default settings for the Agilent 33500 Series. *For your convenience, this table is duplicated inside the rear cover of this manual and on the Quick Reference Card.*

Note: The power-on state will be different than that in the table if you have enabled the power-down recall mode. See “Instrument State Storage” on page 167.

Factory Default Settings**Agilent 33500 Series Factory Default Settings**

Output Configuration	Factory Setting
Function	Sine wave
Frequency	1 kHz
Amplitude / Offset	100 mVpp / 0 VDC
Output Units	Vpp
Output Termination	50 Ω
Autorange	On
Modulation	Factory Setting
Carrier (AM, FM, PM, FSK)	1 kHz Sine wave
Carrier (PWM)	1 kHz Pulse
Mod. Waveform (AM)	100 Hz Sine wave
Mod. Waveform (FM, PM, PWM)	10 Hz Sine wave
AM Depth	100%
FM Deviation	100 Hz
PM Deviation	180 degrees
FSK Hop Frequency	100 Hz
FSK Rate	10 Hz
PWM Width Deviation	10 μ s
Modulation State	Off
Sweep	Factory Setting
Start / Stop Frequency	100 Hz / 1 kHz
Sweep Time	1 Second
Sweep Mode	Linear
Sweep State	Off
Burst	Factory Setting
Burst Count	1 Cycle
Burst Period	10 ms
Burst Start Phase	0 degrees
Burst State	Off
System-Related Operations	Factory Setting
• Power-Down Recall	• Disabled
Display Mode	On
Error Queue	Errors are Cleared
Stored States, Stored Arbs	No Change
Output State	Off
Triggering Operations	Factory Setting
Trigger Source	Internal (Immediate)
Remote Interface Configuration	Factory Setting
• GPIB Address	• 10
• DHCP	• On
• Auto IP	• On
• IP Address	• 169.254.2.20
• Subnet Mask	• 255.255.0.0
• Default Gateway	• 0.0.0.0
• DNS Server	• 0.0.0.0
• Host Name	• none
• Domain Name	• none
Calibration	Factory Setting
Calibration State	Secured

Parameters marked with a bullet (•) are stored in *non-volatile* memory.

Application Programs

Application Programs

This chapter contains several remote interface example programs to help you develop programs for your own application. The *Agilent 33500 Series Programmer's Reference Help* lists the syntax for the SCPI (*Standard Commands for Programmable Instruments*) commands available to program the waveform generator.

Introduction

Nine example programs are included in this chapter to demonstrate controlling the Agilent 33500 Series using SCPI commands. All of these programs are written in Microsoft® C and Microsoft® Visual BASIC® 6.0 and use Agilent VISA-COM.



The programs are included on the “Agilent 33500 Series Product Reference CD-ROM” shipped with the waveform generator. These files are located under the “Programming Examples” link on the CD.

If you want to modify the example programs, or write your own programs and compile them, you will need to install the Agilent IO Libraries Suite software. You can install this software from the “Agilent E2094 Automation-Ready CD-ROM” that is also provided with the 33500 Series.

You may have previously installed the IO Libraries Suite software that was provided with other Agilent products (such as an Agilent GPIB card). However, you must have Agilent IO Libraries Suite 14.0 or a later version to support the examples that are provided on the Product Reference CD-ROM.

For information on obtaining the Agilent IO Libraries Suite software, see:
www.agilent.com/find/iolib

Microsoft® and Visual BASIC® are U.S. registered trademarks of Microsoft Corporation.

Once you have installed the appropriate software components, see “Remote Interface Configuration” in chapter 3 for information on configuring your interface.

The programs listed in this chapter are protected by copyright.

Copyright © 2010 Agilent Technologies, Inc.

You have a royalty-free right to use, modify, reproduce and distribute the Sample Application Files (and/or any modified version) in any way you find useful, provided that you agree that Agilent has no warranty, obligations, or liability for any Sample Application Files.

Agilent Technologies provides programming examples for illustration only. All sample programs assume that you are familiar with the programming language being demonstrated and the tools used to create and debug procedures. Agilent support engineers can help explain the functionality of Agilent software components and associated commands, but they will not modify these samples to provide added functionality or construct procedures to meet your specific needs.

All of the sample application programs in this chapter are example programs intended for use with Microsoft Visual Basic 6.0 and Agilent VISA-COM.

To use the IO object in Visual Basic:

1. Set the reference to include the libraries in the Project/References menu. VISA COM requires a COM reference to the VISA COM 3.0 Type library. Establish a reference in the menu:
Project > References ...
2. Use a statement such as “Dim Fgen As VisaComLib.FormattedIO488” to create the formatted IO reference, and use
“Set Fgen = New VisaComLib.FormattedIO488” to create the actual object.

Program Listings

Example: A Simple Sine Waveform

This program (found in the “Examples\chapter6\SimpleSine” subdirectory on the CD-ROM) selects the function as “sine,” and then sets the frequency, amplitude and offset of the waveform.

```
' *****  
' This Simple Sine program enables a simple sine wave output on channel 1  
' of a 33500 Series instrument with the following signal characteristics:  
'  
'Wave Shape:      Sine  
'Frequency:       1000 Hz  
'Amplitude:       2 Volt Peak to Peak  
'Offset:          0 Volt  
'Output Impedence: 50 Ohm  
'Channell Output: Enabled  
'  
' *****  
  
Private Sub Command1_Click()  
  
    Dim io_mgr As VisaComLib.ResourceManager  
    Dim mfIo As VisaComLib.FormattedIO488  
  
    Set io_mgr = New AgilentRMLib.SRMCls  
    Set mfIo = New FormattedIO488  
    Set mfIo.IO = io_mgr.Open(Text1.Text, NO_LOCK, 2000, "")  
  
    On Error GoTo MyError  
  
    ' This program sets up a waveform by selecting the waveshape  
    ' and adjusting the frequency, amplitude, and offset.
```

```
With mfIo
    ' Clear and reset instrument
    .WriteString "*CLS"
    .WriteString "*RST"

    Sleep 1000

    'Send commands to set the desired configuration
    .WriteString "SOURCE1:FUNCTION SIN"
    .WriteString "SOURCE1:FREQUENCY 1000"
    .WriteString "SOURCE1:VOLT:UNIT VPP"
    .WriteString "SOURCE1:VOLT 2"
    .WriteString "SOURCE1:VOLT:OFFSET 0"
    .WriteString "OUTPUT1:LOAD 50"

    'Enable output.
    .WriteString "OUTPUT1 ON"

    Sleep 1000

End With
Text2.Text = "Sine Wave output set on Channel1"

Exit Sub

MyError:
    Text2 = Err.Description
    Resume Next

End Sub

Private Sub Form_Load()
    Text2.Text = ""
End Sub

End Sub
```



```
'Enable AM Modulation
.WriteString "SOURCE1:AM:STATE ON"

'Enable output
.WriteString "OUTPUT1 ON"

Sleep 1000

End With

Text2.Text = "Amplitude modulation output enabled"

Exit Sub

MyError:
    Text2 = Err.Description
    Resume Next

End Sub

Private Sub Form_Load()
    Text2.Text = ""
End Sub
```



```
.WriteString "SOURCE1:SWEEP:STATE ON"  
  
'Enable output  
.WriteString "OUTPUT1 ON"  
  
Sleep 1000  
  
End With  
Text2.Text = "Sweep Output enabled"  
  
Exit Sub  
  
MyError:  
    Text2 = Err.Description  
    Resume Next  
  
End Sub  
  
Private Sub Form_Load()  
    Text2.Text = ""  
  
End Sub
```

Example: A Pulse Waveform

This program (found in the “Examples\chapter6\Pulse” subdirectory on the CD-ROM) configures a pulse waveform, setting pulse width, period, and high/low levels. The edge time is then incremented.

```

' *****
' This Pulse program enables a simple pulse wave output on channel 1 of a
' 33500 Series instrument with signal characteristics given below. A loop
' in the program increases the edge transition time by 10 nsec every 100 msec.

'Wave Shape:          Pulse
'Frequency:           100 KHz
'Amplitude:           2 Volts Peak to Peak
'Offset:              0 Volt
'Edge Transition Time: Variable (10 ns to 100 ns in 10 ns steps every 100 msec)
'Channell Output:     Enabled
'
' *****
Private Declare Sub Sleep Lib "kernel32" (ByVal dwMilliseconds As Long)

Private Sub Command1_Click()

    Dim io_mgr As VisaComLib.ResourceManager
    Dim mfIo As VisaComLib.FormattedIO488
    Dim i As Integer

    Set io_mgr = New AgilentRMLib.SRMClS
    Set mfIo = New FormattedIO488
    Set mfIo.IO = io_mgr.Open(Text1.Text, NO_LOCK, 2000, "")

    On Error GoTo MyError

    ' This program sets up a waveform by selecting the waveshape
    ' and adjusting the frequency, amplitude, and offset.

    With mfIo

        'Clear and reset instrument
        .WriteString "*CLS"
        .WriteString "*RST"

        Sleep 1000

        'Set function to Pulse.
        .WriteString "SOURCE1:FUNCTION PULSE"

        'Set pulse period (sec) & voltage
        .WriteString "SOURCE1:FUNCTION:PULSE:PERIOD 1E-3"
        .WriteString "SOURCE1:VOLT 5"

        'Set Duty Cycle to 50%
        .WriteString "SOURCE1:FUNCTION:PULSE:DCYCLE 50"

        'Enable output.
        .WriteString "OUTPUT1 ON"

        Sleep 1000
    End With
End Sub
```

```
' Iterate over different pulse transition durations
For i = 1 To 10
    .WriteString "SOURCE1:FUNCTION:PULSe:TRANSition " & (i * 10) & "E-9"
    Sleep 100
Next i

End With
Text2.Text = "Pulse output with variable edge time set on Channell"

Exit Sub

MyError:
    Text2 = Err.Description
    Resume Next

End Sub

Private Sub Form_Load()
    Text2.Text = ""
End Sub
```

Example: Download Arbitrary Waveform as ASCII

This program (found in the "Examples\chapter6\Pulse" subdirectory on the CD-ROM) configures a pulse waveform, setting pulse width, period, and high/low levels. The edge time is then incremented.

```
' *****  
'This AsciiArb program demonstrates how to download an arbitrary waveform into  
'instrument volatile memory and play it back with the configuration below:  
'  
'Wave Shape:          Arb  
'Frequency:           40 KSa/Sec  
'Amplitude:           2 Volt Peak to Peak  
'Offset:              0 Volt  
'Output Impedance:    50 Ohm  
'Channel1 Output:     Enabled  
  
'This arb generates a 4000 point pulse waveform, of which the first 200 points  
'define a positive pulse from 0 volts to the maximum defined voltage amplitude.  
  
'Caution: This program will erase all unsaved data in volatile memory.  
'If necessary, save that information before running this example program.  
' *****
```

```
Private Sub Command1_Click()
```

```
    Dim io_mgr As VisaComLib.ResourceManager  
    Dim mFio As VisaComLib.FormattedIO488  
  
    Set io_mgr = New AgilentRMLib.SRMClS  
    Set mFio = New FormattedIO488  
    Set mFio.IO = io_mgr.Open(Text1.Text, NO_LOCK, 2000, "")  
  
    Dim Waveform() As String  
    Dim I As Integer  
    Dim DataStr As String  
    ReDim Waveform(1 To 4000)  
  
    On Error GoTo MyError  
  
    'Compute waveform  
  
    Text2.Text = ""  
    Text2.Text = Text2.Text & "Computing Waveform..." & vbCrLf  
  
    For I = 1 To 5  
        Waveform(I) = Str$((I - 1) / 5)        ' Set rise time (5 points)  
    Next I  
  
    For I = 6 To 205  
        Waveform(I) = "1"                    ' Set pulse width (200 points)  
    Next I  
  
    For I = 206 To 210  
        Waveform(I) = Str$((210 - I) / 5)    ' Set fall time (5 points)  
    Next I  
  
    For I = 211 To 4000  
        Waveform(I) = "0"                    ' Set remaining points to zero  
    Next I
```

```

DataStr = Join(Waveform, ",")           ' Create string from data array

With mFio

    'Clear and reset instrument and increase the Visa Connection timeout to 40
    'seconds for downloading a long waveform
    .WriteString "*CLS"
    .WriteString "*RST"
    .IO.Timeout = 40000

    Sleep 1000

    Call WaitForOPC(mFio)

    '
    '*** Clearing Volatile memory ***
    'Caution: This program will erase all unsaved data in volatile memory.
    'If necessary, save that information before running this example program.
    '

    .WriteString "DATA:VOLatile:CLEar"

End With

    'Downloading Waveform
    Text2.SelStart = Len(Text2.Text)
    Text2.SelText = "Downloading Waveform..." & vbCrLf

With mFio
    .WriteString "SOURce1:DATA:ARbitrary TestArb," & DataStr
End With

Call WaitForOPC(mFio)

Text2.Text = Text2.Text & "Download Complete" & vbCrLf

With mFio

    'Send command to set the desired configuration
    .WriteString "SOURce1:FUNCTION:ARbitrary TestArb" ' set current arbitrary
waveform to defined arb pulse
    .WriteString "SOURce1:VOLT 2" ' set max waveform amplitude to 2 Vpp
    .WriteString "SOURce1:VOLT:OFFSET 0" ' set offset to 0 V
    .WriteString "OUTPUT1:LOAD 50" ' set output load to 50 ohms
    .WriteString "SOURce1:FUNCTION:ARB:SRATE 40000" ' set sample rate
    .WriteString "SOURce1:FUNCTION:ARB" ' turn on arb function

    'This example creates an arbitrary waveform in volatile memory.
    'To save the waveform to non-volatile memory, use one of the following
commands:
    'MMEMory:STOR:DATA1 "INT:\TESTARB.arb" 'Stores the arb to internal memory as
TESTARB.arb
    'MMEMory:STOR:DATA1 "USB:\TESTARB.arb" 'Stores the arb to a USB flash drive as
TESTARB.arb

    'Enable output
    .WriteString "OUTPUT1 ON" 'turn on channel 1 output

    Sleep 1000

End With

```

Chapter 4 Application Programs

Program Listings

```
Text2.Text = Text2.Text & "Arb Wave output set on Channel1" & vbCrLf

Exit Sub

MyError:
    Text2 = Err.Description
    Resume Next

End Sub

Private Sub Form_Load()
    Text2.Text = ""
End Sub

Private Function WaitForOPC(mFio As VisaComLib.FormattedIO488)
    Do
        Dim strResult As String
        With mFio
            .WriteString "*OPC?"
            strResult = .ReadString()
        End With

        If (InStr(strResult, "1") > 0) Then
            Exit Do
        End If
    Loop
End Function
```

Example: Sequencing

This program (found in the “Examples\chapter6\PulseWidthMod” subdirectory on the CD-ROM) configures a pulse waveform with duty cycle, which is then slowly modulated by a triangle waveform.

```

' *****
' This Arb Sequence program demonstrates how to define an Arb Sequence consisting
' of one or more different arbitrary waveform segments and play it back using the
' following configuration:
'
'   Wave Shape:      Arb Sequence
'   Frequency:      40 KSa/Sec
'   Amplitude:      2 Volt Peak to Peak
'   Offset:         0 Volt
'   Output Impedance: 50 Ohm
'   Channell Output: Enabled
'
'Caution: This program will erase all unsaved data in volatile memory.
'If necessary, save that information before running this example program.
' *****

Private Sub Command1_Click()

    Dim io_mgr As VisaComLib.ResourceManager
    Dim mFio As VisaComLib.FormattedIO488

    Set io_mgr = New AgilentRMLib.SRMCl1
    Set mFio = New FormattedIO488
    Set mFio.IO = io_mgr.Open(Text1.Text, NO_LOCK, 2000, "")

    Dim Waveform() As String
    Dim I As Integer
    Dim DataStr As String
    ReDim Waveform(1 To 4000)
    Dim strSeqDescriptor As String
    Dim strHeader As String
    Dim strCommand As String

    On Error GoTo MyError

    'Compute waveform

    Text2.Text = ""

    With mFio

        'Clear and reset instrument
        .WriteString "*CLS"
        .WriteString "*RST"

        Sleep 1000

        Call WaitForOPC(mFio)

        '
        ' *** Clearing Volatile memory ***
        ' Caution: This program will erase all unsaved data in volatile memory.
        ' If necessary, save that information before running this example program.
        '

        .WriteString "DATA:VOLatile:CLEar"
    
```

Chapter 4 Application Programs

Program Listings

End With

```
'Loading arb files into waveform memory.  
With mFio
```

```
.WriteString "MMEM:LOAD:DATA ""INT:\BUILTIN\SINC.ARB"""  
Call WaitForOPC(mFio)  
.WriteString "MMEM:LOAD:DATA ""INT:\BUILTIN\CARDIAC.ARB"""  
Call WaitForOPC(mFio)  
.WriteString "MMEM:LOAD:DATA ""INT:\BUILTIN\HAVERSINE.ARB"""  
Call WaitForOPC(mFio)
```

End With

```
'Build a sequence descriptor string consisting of arbitrary waveform segments.  
strSeqDescriptor = "mySequence"  
strSeqDescriptor = strSeqDescriptor & "," +  
""INT:\BUILTIN\SINC.ARB"",5,once,maintain,12"  
strSeqDescriptor = strSeqDescriptor & "," +  
""INT:\BUILTIN\CARDIAC.ARB"",5,repeat,highAtStart,35"  
strSeqDescriptor = strSeqDescriptor & "," +  
""INT:\BUILTIN\HAVERSINE.ARB"",0,once,lowAtStart,10"  
strSeqDescriptor = strSeqDescriptor & "," +  
""INT:\BUILTIN\SINC.ARB"",0,once,highAtStartGoLow,7"
```

```
'Calculate the header of the sequence command.  
strHeader = "#" & CStr(Len(CStr(Len(strSeqDescriptor)))) &  
CStr(Len(strSeqDescriptor))
```

```
'Append the header information and sequence descriptor.  
strCommand = "SOURCE1:DATA:SEQ " & strHeader & strSeqDescriptor
```

With mFio

```
'Send command to set the desired configuration  
.WriteString strCommand  
Call WaitForOPC(mFio)  
.WriteString "SOURCE1:FUNCTION:ARBITRARY mySequence"  
.WriteString "SOURCE1:VOLT 2"  
.WriteString "SOURCE1:VOLT:OFFSET 0"  
.WriteString "OUTPUT1:LOAD 50"  
.WriteString "SOURCE1:FUNCTION:ARB:SRATE 40000"  
.WriteString "SOURCE1:FUNCTION ARB"
```

```
'Enable output.  
.WriteString "OUTPUT1 ON"
```

Sleep 1000

End With

```
Text2.SelText = "Arbitrary Wave Sequence generated on Channell" & vbCrLf
```

Exit Sub

MyError:

```
Text2 = Err.Description  
Resume Next
```



```
End Sub

Private Sub Form_Load()
    Text2.Text = ""
End Sub

Private Function WaitForOPC(mFio As VisaComLib.FormattedIO488)
    Do
        Dim strResult As String

        With mFio
            .WriteString "*OPC?"
            strResult = .ReadString()
        End With

        If (InStr(strResult, "1") > 0) Then
            Exit Do
        End If
    Loop
End Function
```

Example: Two-channel Output

This program (found in the “Examples\chapter6\PulseWidthMod” subdirectory on the CD-ROM) configures a pulse waveform with duty cycle, which is then slowly modulated by a triangle waveform.

```
' *****
'This 2_Channel_output program demonstrates the functionality of driving
'two different waveform outputs on the two channels of a 33522A instrument with
'following waveform characteristics.
'
'Channel 1 Parameters:
'Wave Shape:      Sine
'Frequency:       1000 Hz
'Amplitude:       2 Volt Peak to Peak
'Offset:          0 Volt
'Load Impedance: 50 Ohm
'Channel1 Output: Enabled
'
'Channel 2 Parameters:
'Wave Shape:      Square
'Frequency:       20 KHz
'Amplitude:       1 Volt RMS
'Offset:          1 Volt
'Load Impedance: 10 KOhm
'Channel2 Output: Enabled
'
' *****

Private Sub Command1_Click()

    Dim io_mgr As VisaComLib.ResourceManager
    Dim mfIo As VisaComLib.FormattedIO488

    Set io_mgr = New AgilentRMLib.SRMClS
    Set mfIo = New FormattedIO488
    Set mfIo.IO = io_mgr.Open(Text1.Text, NO_LOCK, 2000, "")

    On Error GoTo MyError

    With mfIo

        'Clear and reset instrument
        .WriteString "*CLS"
        .WriteString "*RST"

        Sleep 1000

        ' Send commands to set channel 1 to desired configuration
        .WriteString "SOURCE1:FUNCTION SIN"
        .WriteString "SOURCE1:FREQUENCY 1000"
        .WriteString "SOURCE1:VOLT:UNIT VPP"
        .WriteString "SOURCE1:VOLT 2"
        .WriteString "SOURCE1:VOLT:OFFSET 0"
        .WriteString "OUTPUT1:LOAD 50"

        ' Send commands to set channel 2 to desired configuration
```

```
.WriteString "SOURCE2:FUNCTION SQU"  
.WriteString "SOURCE2:FREQUENCY 20E3"  
.WriteString "SOURCE2:VOLT:UNIT VRMS"  
.WriteString "SOURCE2:VOLT 1"  
.WriteString "SOURCE2:VOLT:OFFSET 1"  
10 Kohm .WriteString "OUTPUT2:LOAD MAX" 'Maximum load impedance corresponds to  
  
    ' Enable channel 1 output  
    .WriteString "OUTPUT1 ON"  
  
    ' Enable channel 2 output  
    .WriteString "OUTPUT2 ON"  
  
    Sleep 1000  
  
End With  
Text2.Text = "Output set on both channels"  
  
Exit Sub  
  
MyError:  
    Text2 = Err.Description  
    Resume Next  
  
End Sub  
  
Private Sub Form_Load()  
    Text2.Text = ""  
  
End Sub
```

Example: Sine Burst with Sync

This program (found in the “Examples\chapter6\PulseWidthMod” subdirectory on the CD-ROM) configures a pulse waveform with duty cycle, which is then slowly modulated by a triangle waveform.

```

' *****
' * This Sine Burst With Sync program demonstrates the synchronization of two
' * 33522A instruments.
' * A BUS trigger on the first instrument starts an infinite burst of one waveform,
' * and an EXTERNAL
' * trigger on the second instrument starts an infinite burst of a different waveform.
' * The first instrument is configured to fire an output trigger from its
' * EXT TRIG IN/OUT rear connection when its burst starts. The EXT TRIG IN/OUT output
' * from the first instrument is connected by a signal cable to the EXT TRIG IN/OUT on
' * the second instrument. In this way, the second burst starts at the same time as
' * the first instrument burst. For tight synchronization, the 10MHz output of the
' * first instrument should also be connected to the 10 MHz input connector of the
' * second instrument.
'
'Instrument 1 Configuration, Channel 1:
'Wave Shape:      Sine
'Frequency:       1000 Hz
'Amplitude:       2 Volt Peak to Peak
'Offset:          0 Volt
'Load Impedance:  50 Ohm
'Channel 1 Output: Enabled
'
'Instrument 2 Configuration, Channel 1:
'Wave Shape:      Ramp
'Frequency:       2 KHz
'Amplitude:       1 Volt Peak to Peak
'Offset:          1 Volt
'Load Impedance:  50 Ohm
'Channel 1 Output: Enabled
'*****

Private Sub Command1_Click()

    Dim io_mgr As VisaComLib.ResourceManager
    Dim mfIo1 As VisaComLib.FormattedIO488
    Dim mfIo2 As VisaComLib.FormattedIO488

    Set io_mgr = New AgilentRMLib.SRMCLs
    Set mfIo1 = New FormattedIO488
    Set mfIo2 = New FormattedIO488

    Set mfIo1.IO = io_mgr.Open(Text1.Text, NO_LOCK, 2000, "")
    Set mfIo2.IO = io_mgr.Open(Text2.Text, NO_LOCK, 2000, "")

    On Error GoTo MyError

    ' Clear and reset instruments
    With mfIo1
        .WriteString "*CLS"
        .WriteString "*RST"
    End With

End With
```

```

With mfIo2
    .WriteString "*CLS"
    .WriteString "*RST"

End With

Sleep 2000

With mfIo1
    ' Set up instrument 1
    ' Send commands to set channel 1 on instrument 1 to desired configuration
    .WriteString "SOURCE1:FUNCTION SIN"
    .WriteString "SOURCE1:FREQUENCY 1000"
    .WriteString "SOURCE1:VOLT:UNIT VPP"
    .WriteString "SOURCE1:VOLT 2"
    .WriteString "SOURCE1:VOLT:OFFSET 0"
    .WriteString "OUTPUT1:LOAD 50"

    ' Set trigger mode to BUS for instrument 1
    .WriteString "TRIGGER1:SOURCE BUS"

    ' Set up and turn on infinite cycle burst with infinite cycle output
    ' This burst will start on instrument 1 when instrument receives a BUS
    ' trigger (*TRG)
    .WriteString "SOURCE1:BURST:NCYCLES INF"
    .WriteString "SOURCE1:BURST:MODE TRIG"
    .WriteString "SOURCE1:BURST:STATE ON"

    ' Set up the output trigger on instrument to output a positive pulse when
    ' its burst starts
    .WriteString "OUTPUT:TRIGGER ON"
    .WriteString "OUTPUT:TRIGGER:SLOPE POSITIVE"
    .WriteString "OUTPUT:TRIGGER:SOURCE CH1"

    ' turn off continuous INIT as we are just using one trigger to start the
    ' burst
    .WriteString "INITIATE1:CONTINUOUS OFF"
    ' arm instrument 1 with INIT so it waits for BUS trigger to start burst
    .WriteString "INITIATE1"

End With

With mfIo2
    ' Set up instrument 2
    ' Send commands to set channel 1 on instrument 2 to desired configuration
    .WriteString "SOURCE1:FUNCTION RAMP"
    .WriteString "SOURCE1:FREQUENCY 2000"
    .WriteString "SOURCE1:VOLT:UNIT VPP"
    .WriteString "SOURCE1:VOLT 1"
    .WriteString "SOURCE1:VOLT:OFFSET 1"
    .WriteString "OUTPUT1:LOAD 50"

    ' Set trigger mode to EXT for instrument 2
    .WriteString "TRIGGER1:SOURCE EXT"
    ' Set slope of rear external trigger to positive edge
    .WriteString "TRIGGER1:SLOPE POSITIVE"

    ' Set up and turn on infinite cycle burst with infinite cycle output
    ' This burst will start on instrument 2 when the instrument receives a
    ' positive TTL pulse (EXT trigger) on its rear EXT TRIG IN port

```

Chapter 4 Application Programs

Program Listings

```
.WriteString "SOURCE1:BURST:NCYCLES INF"
.WriteString "SOURCE1:BURST:MODE TRIG"
.WriteString "SOURCE1:BURST:STATE ON"
' turn off continuous INIT as we are just using one trigger to start the
burst
    .WriteString "INITiate1:CONTinuous OFF"
    ' arm instrument 2 with INIT so it waits for EXT trigger to start burst
    .WriteString "INITiate1"

End With

With mFIo1

    'Enable channel 1 output on instrument 1
    .WriteString "OUTPUT1 ON"
End With

With mFIo2
    'Enable channel 1 output on instrument 2
    .WriteString "OUTPUT1 ON"

End With

Sleep 2000

With mFIo1

    'Start burst on channel 1 with BUS trigger
    .WriteString "*TRG"

End With

On Error GoTo MyError

mFIo1.IO.Close
mFIo2.IO.Close

Text3.Text = "Output set on both instruments"

Exit Sub

MyError:

    Text3 = Err.Description
    Resume Next

End Sub

Private Sub Form_Load()

    Text3.Text = ""

End Sub
```

Example: Signal Sum

This program (found in the “Examples\chapter6\Signal Sum Example” subdirectory on the CD-ROM) configures a pulse waveform with duty cycle, which is then slowly modulated by a triangle waveform.

```

*****
' Copyright © 2010 Agilent Technologies Inc. All rights
' reserved.
'
' You have a royalty-free right to use, modify, reproduce and distribute
' the Sample Application Files (and/or any modified version) in any way
' you find useful, provided that you agree that Agilent has no
' warranty, obligations or liability for any Sample Application Files.
'
' Agilent Technologies provides programming examples for illustration only,
' This sample program assumes that you are familiar with the programming
' language being demonstrated and the tools used to create and debug
' procedures. Agilent support engineers can help explain the
' functionality of Agilent software components and associated
' commands, but they will not modify these samples to provide added
' functionality or construct procedures to meet your specific needs.
*****

*****
' This sample program is intended for use with Microsoft Visual studio 6.0
' and Agilent Visa Object library.
'
' Sample program execution requires VISA library installation.
'
' Add libraries below in Project\reference menu before executing sample 'program:
' VISA COM 3.0 Type Library, Location: <visa install location>\VisaCom\GlobMgr.dll
' VISA COM 488.2 Formatted I/O 1.0, Location:
' <visa install location>\VisaCom\BasFrmIO.dll
' VISA COM Resource Manager 1.0, Location:
' <Agilent IO Library install>\bin\Agtrm.dll
*****

' *****
'
' "*****"
' Signal SUM Example is a sample program to demonstrate the capability of adding two
' Channels function and get the output
'
' Algorithm:
' 1. Set the base signals to sum on Channel1 & Channel2.
' 2. Set the SUM modulation on Channel 1.
' 3. Source for SUM modulation will be Channel2 function.
' 4. Set Sum Amplitude.
' 4. Enable modulation output.
' 5. Enable channels output.
' 6. For Verification, we can route the signal to oscilloscope and see the result.
'
' Channel 1 Parameters:
' Wave Shape: Sine
' Frequency: 1000 Hz
' Amplitude: 2 Volt Peak to Peak
' Offset: 0 Volt
' Output Impedance: 50 Ohm
'
' Channel 2 Parameters:
' Wave Shape: Square
' Frequency: 1000 Hz

```

Chapter 4 Application Programs

Program Listings

```
' Amplitude: 2 Volt Peak to Peak
' Offset: 0 Volt
' Output Impedence: 50 Ohm
'
'Modulation:
' Modulation type: Sum Modulation.
' Sum Amplitude: 1 V
'
' Sum State: ON
'
' Channel1 Output: Enabled
' Channel2 Output: Enabled
'
'*****
Private Sub Command1_Click()

    Dim io_mgr As VisaComLib.ResourceManager
    Dim mfIo As VisaComLib.FormattedIO488

    Set io_mgr = New AgilentRMLib.SRMClS
    Set mfIo = New FormattedIO488
    Set mfIo.IO = io_mgr.Open(Text1.Text, NO_LOCK, 2000, "")

    On Error GoTo MyError

    ' This program sets up a waveform by selecting the waveshape
    ' and adjusting the frequency, amplitude, and offset.

    With mfIo

        'Reset and clear instrument
        .WriteString "*RST"
        .IO.Clear

        'Send Command to set the desired configuration on Channel 1
        .WriteString "SOURCE1:FUNCTION SIN"
        .WriteString "SOURCE1:FREQUENCY 1000"
        .WriteString "SOURCE1:VOLT:UNIT VPP"
        .WriteString "SOURCE1:VOLT 2"
        .WriteString "SOURCE1:VOLT:OFFSET 0"
        .WriteString "OUTPUT1:LOAD 50"

        'Send Command to set the desired configuration on Channel 2
        .WriteString "SOURCE2:FUNCTION SQU"
        .WriteString "SOURCE2:FREQUENCY 1000"
        .WriteString "SOURCE2:VOLT:UNIT VPP"
        .WriteString "SOURCE2:VOLT 2"
        .WriteString "SOURCE2:VOLT:OFFSET 0"
        .WriteString "OUTPUT2:LOAD 50"

        'Set Sum Modulation parameter
        .WriteString "SOURCE1:SUM:SOURCE CH2"
        .WriteString "SOURCE1:SUM:AMPLITUDE 1"
        .WriteString "SOURCE1:SUM:STATE 1"

        'Enable output.
        .WriteString "OUTPUT1 ON"
        .WriteString "OUTPUT2 ON"

    End With

    Text2.Text = "Output set as SUM signal on Channel 1"
```



```
Exit Sub
MyError:
    Text2 = Err.Description
    Resume Next
End Sub
Private Sub Form_Load()
    Text2.Text = ""
End Sub
```

Tutorial

Tutorial

This chapter will help you get the most from your 33500 Series waveform generator by describing certain aspects of its internal operation and the signals it generates

- Arbitrary Waveforms, page 244
- Quasi-Gaussian Noise, page 246
- PRBS, page 246
- Modulation, page 248
- Burst, page 251
- Frequency Sweep, page 253
- Attributes of AC Signals, page 254
- Signal Imperfections, page 257
- Ground Loops, page 258

Arbitrary Waveforms

You can define arbitrary waveforms to fill needs not met by the instrument's standard waveforms. For example, your device under test might require a unique stimulus or you might want to simulate real-world signal imperfections such as overshoot, ringing, glitches, and noise. Also, arbitrary waveforms can be very complex, making them suitable for simulating the signals that occur in modern communications systems.

For each channel, you can create arbitrary waveforms of up to 1,000,000 points (16,000,000 points with Option 002). The instrument stores these numeric data points, known as “samples,” in memory and then converts them into voltages as the waveform is generated. The frequency at which points are read is the “sample rate,” and the waveform frequency equals the sample rate divided by the number of points in the waveform. For example, suppose a waveform has 37 points and the sample rate is 162.4 MHz. The frequency would be $(162.4 \text{ MHz})/37 = 4.389 \text{ MHz}$ and its period, which is the reciprocal of its frequency, would be 227.8 ns.

$$\text{frequency} = 1/\text{period} = (\text{sample rate})/(\text{number of points})$$

The maximum frequency of an arbitrary waveform is the maximum sample rate of the instrument, 250 MHz, divided by the number of points in the waveform. Every arbitrary waveform must have at least 8 points.

Waveform Filters The instrument includes two filters to smooth the transitions between points as arbitrary waveforms are generated. The Normal filter setting gives a wide, flat frequency response, but its step response exhibits overshoot and ringing. The Step setting gives a nearly ideal step response, but it has more roll-off in its frequency response than the Normal filter.

Each filter's cutoff frequency is a fixed fraction of the waveform's sample rate. The Normal filter's response is -3 dB at 27% of the sample rate and the Step filter's response is -3 dB at 13% of the sample rate. For example, if you are playing an arbitrary waveform at 100 MSA/s, the Normal filter's -3 dB frequency bandwidth is 27 MHz.

If you turn filtering off, the output changes abruptly between points, with a transition time of approximately 10 ns.

Waveform Sequencing The Agilent 33500 Series can assemble long, complex waveforms from smaller waveforms. The user-definable program that specifies how to do this is called a sequence, and the smaller waveforms are called segments. Switching between segments occurs seamlessly in real time. As an analogy, think of segments as songs in a music player and sequences as play lists.

Each step of a sequence specifies a segment and how many times it is played. It also specifies whether the sequence waits for a trigger before the next step and how the Sync signal is generated on a step-by-step basis.

For each step in the sequence, you can do one of the following:

- play the selected segment from 1 to 1,000,000 times and then advance to the next step
- play the selected segment once and then stop and wait for a trigger before advancing
- repeat the selected segment until a trigger occurs and then advance
- repeat the selected segment until explicitly stopped

Options for Sync signal generation include:

- assert Sync at the beginning of the segment
- negate Sync at the beginning of the segment
- maintain the current Sync state throughout the segment
- assert Sync at the beginning of the segment and negate it at a defined point within the segment.

Quasi-Gaussian Noise

The Noise waveform is generated to be optimized for both quantitative and qualitative statistical properties. Though not truly random, it does not repeat for more than 50 years of continuous operation.

The Noise waveform's voltage distribution is approximately gaussian. Unlike the ideal distribution, though, there is zero probability of getting a voltage outside the range established by the instrument's V_{pp} setting. The distribution's crest factor (peak voltage divided by RMS voltage) is approximately 4.6.

You can vary the Noise bandwidth continuously from 1 MHz to 30 MHz. The energy in the noise signal is concentrated in a band from DC to the selected bandwidth, so the signal has a higher spectral density in the band of interest when the bandwidth setting is lower. In audio work, for example, you might wish to set the bandwidth to 30 kHz, making the signal strength in the audio band 30 dB higher than if the bandwidth were set to 30 MHz.

PRBS

A Pseudo-Random Bit Sequence (PRBS) waveform has two states (high and low) like a Pulse or Square wave, but it switches between them in a manner that is difficult to predict without knowing the sequence generation algorithm. A PRBS is generated by a linear-feedback shift register (LFSR), an example of which is shown below.

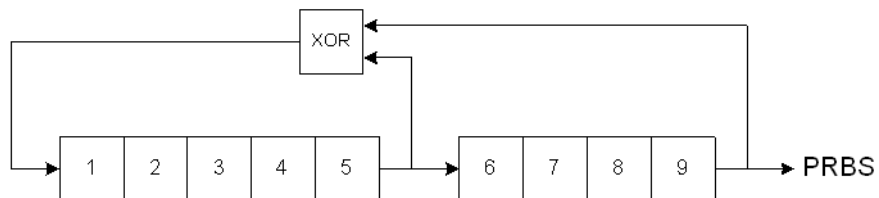

An LFSR is specified by the number of stages it contains and which stages (“taps”) feed the exclusive-or (XOR) gate(s) that comprise its feedback network. The PRBS output is taken from the last stage. With properly chosen taps, an L-stage LFSR produces a repetitive PRBS of length 2^L-1 . The clocking frequency of the LFSR determines the “bit rate” of the PRBS.

In the 33500 Series, you can set L to be 7, 9, 11, 15, 20, or 23, resulting in sequences from 127 to 8,388,607 bits in length.

Modulation

Amplitude Modulation (AM) The 33500 Series implements two forms of AM. The first form is double-sideband full-carrier (DSB-FC). DSB-FC has an ITU designation of A3E and is the type used in AM broadcasting. The second form is double-sideband suppressed-carrier (DSSC). Many modern communications systems employ DSSC on each of two carriers that have the same frequency but a 90-degree phase difference. This is called quadrature amplitude modulation (QAM).

The equation for DSB-FC is

$$y(t) = [(1/2) + (1/2) \cdot d \cdot m(t)] \cdot A_c \cdot \sin(\omega_c t)$$

where

- $m(t)$ is the modulating signal
- A_c is the carrier amplitude
- ω_c is the carrier frequency of the carrier
- d is the “modulation depth,” or fraction of the amplitude range is used by the modulation

For example, a depth setting of 80% varies the amplitude from 10% to 90% of the amplitude setting (90% - 10% = 80%) with either an internal or a full-scale (± 5 -Volt) external modulating signal. You may set depth as high as 120%, as long as you do not exceed the instrument’s maximum output voltage of (± 5 V into 50 Ω , ± 10 V into high impedance).

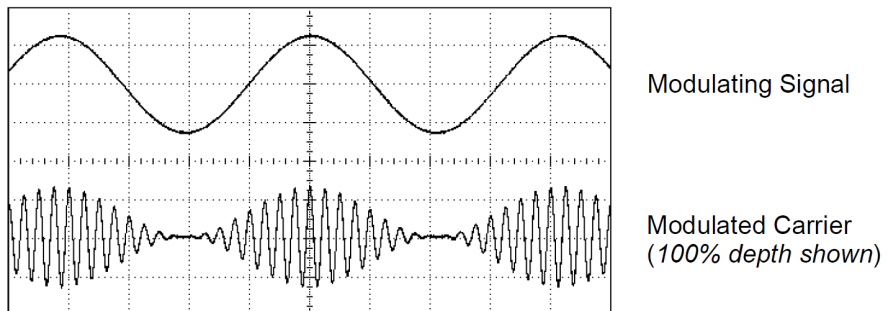

The equation for DSSC is

$$y(t)=d \cdot m(t) \cdot \sin(\omega_c t)$$

In DSB-SC, the carrier signal is inverted whenever $m(t) < 0$. For QAM, the second carrier signal would be $\cos(\omega_c t)$, making it 90 degrees out of phase from the first carrier.

Frequency Modulation (FM) Frequency modulation varies a carrier signal's frequency according to the modulating signal:

$$y(t)=A_c \cdot \sin[(\omega_c + d \cdot m(t)) \cdot t]$$

where $m(t)$ is the modulating signal and d is the frequency deviation. FM is called narrowband if the deviation is less than 1% of the modulating signal's bandwidth, and wideband otherwise. You can approximate the modulated signal's bandwidth with the following equations.

$BW \approx 2 \cdot (\text{Modulating Signal Bandwidth})$ for narrowband FM

$BW \approx 2 \cdot (\text{Deviation} + \text{Modulating Signal Bandwidth})$ for wideband FM

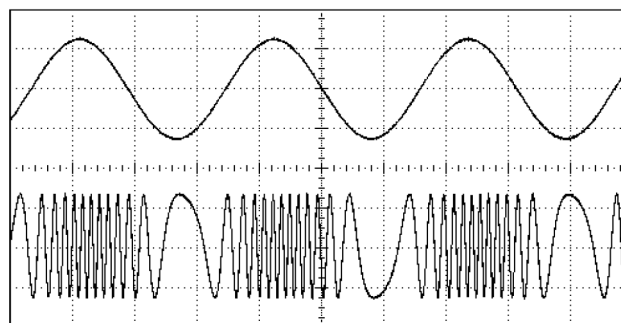

Modulating Signal

Modulated Carrier

Modulation

Phase Modulation (PM) PM is similar to FM, but the phase of the carrier waveform is varied, rather than the frequency:

$$y(t) = \sin[\omega_c t + d \cdot m(t)]$$

where $m(t)$ is the modulating signal and d is the phase deviation.

Frequency-Shift Keying (FSK) FSK is similar to FM, except the carrier frequency alternates between two preset values, the carrier frequency and the hop frequency. Sometimes the hop and carrier frequencies are called “Mark” and “Space,” respectively. The rate at which the frequency switches values is determined by an internal timer or the signal on the rear panel Ext Trig connector. Frequency changes are instantaneous and phase-continuous.

The internal modulating signal is a square wave with 50% duty cycle.

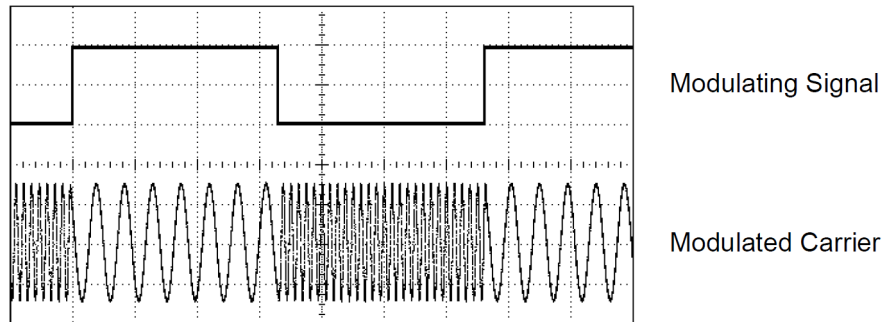

Binary Phase Shift Keying (BPSK) BPSK is similar to FSK, except it is the carrier’s phase, rather than its frequency, that switches between two values. The rate at which the phase switches values is determined by an internal timer or the signal on the rear panel Ext Trig connector. Phase changes are instantaneous.

The internal modulating signal is a square wave with 50% duty cycle.

Pulse Width Modulation (PWM) PWM is only available for the Pulse waveform, and as its name suggests, the pulse width varies according to the modulating signal. The amount by which the pulse width varies is called the width deviation, and it can be specified as a percentage of the waveform period (that is, duty cycle) or in units of time. For example, if you specify a pulse with 20% duty cycle and then enable PWM with a 5% deviation, the duty cycle will vary from 15% to 25% under control of the modulating signal.

Additive Modulation (Sum) The “Sum” feature adds the modulating signal to the carrier. For example, you can add controlled amounts of variable-bandwidth noise to a signal or create two-tone signals. The internal modulation generator in the 33500 Series can produce the same continuous waveform as the main generator, so the Sum function lets you to create many signals that would have required two instruments before.

The Sum feature increases the amplitude of the output signal by the amplitude of the modulating signal. This might cause the instrument to switch to a higher output-voltage range, resulting in a momentary signal loss. If this is a problem in your application, turn on the Range Hold function. If the voltage increase could damage your device under test, apply Voltage Limits.

Burst

You can configure the waveform generator to output a waveform with a specified number of cycles, called a *burst*. You can use burst in one of two modes: *N-Cycle Burst* (also called “triggered burst”) or *Gated Burst*.

N-Cycle Burst An N-Cycle burst consists of a specific number of waveform cycles (1 to 1,000,000) and is always initiated by a trigger event. You can also set the burst count to “Infinite” which results in a continuous waveform once the waveform generator is triggered.

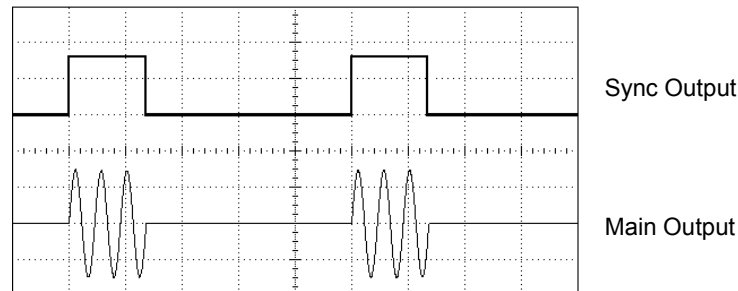

Three-Cycle Burst Waveform

Burst

For bursts, the trigger source can be an external signal, an internal timer, the **Trigger** key, or a command received from the remote interface. The input for external trigger signals is the rear-panel *Ext Trig* connector. This connector accepts TTL-compatible levels and is referenced to chassis ground (not floating ground). When not used as an input, the *Ext Trig* connector can be configured as an output to enable the 33500 Series to trigger other instruments at the same time that its internal trigger occurs.

An N-Cycle burst always begins and ends at the same point in the waveform, called the *start phase*.

Gated Burst In the Gated burst mode, the output waveform is either “on” or “off” based on the level of the external signal applied to the rear-panel *Ext Trig* connector. When the gate signal is *true*, the waveform generator outputs a continuous waveform. When the gate signal goes *false*, the current waveform cycle is completed and then the waveform generator stops while remaining at the voltage level corresponding to the start phase of the selected waveform. For a noise waveform, the output stops immediately when the gate signal goes false.

Frequency Sweep

Frequency sweeping is similar to FM, but no modulating waveform is used. Instead, the instrument sets the output frequency based on either a linear or logarithmic function, or a list of up to 128 user-specified frequencies. In a linear sweep the output frequency changes in a constant “hertz per second” manner, but in a logarithmic sweep the frequency changes in a constant “octaves per second” or “decades per second” way. Logarithmic sweeps let you cover wide frequency ranges where resolution at low frequencies could be lost with a linear sweep.

Frequency sweeps are characterized by a sweep time (during which the frequency changes smoothly from the start frequency to the stop frequency), a hold time (during which the frequency stays at the stop frequency), and a return time (during which the frequency returns smoothly to the start frequency). Trigger settings determine when the next sweep begins. The returns are always linear.

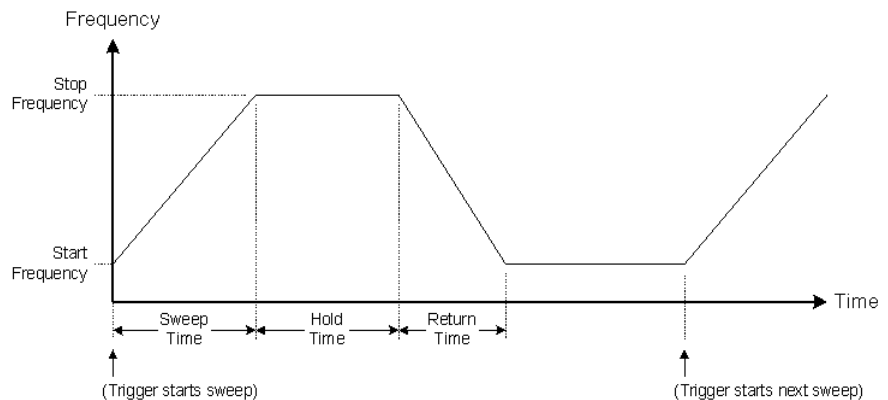

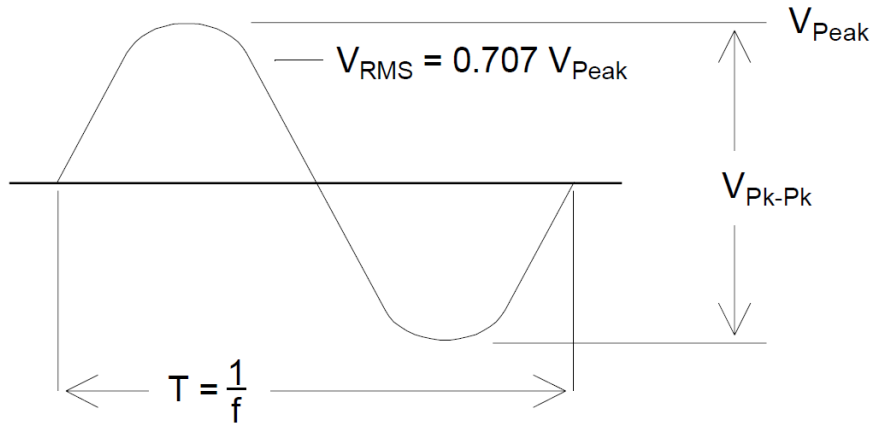

Attributes of AC Signals

The most common AC signal is a sine wave. In fact, any periodic signal can be represented as the sum of different sine waves. The magnitude of a sine wave is usually specified by its peak, peak-to-peak, or root-mean-square (RMS) value. All of these measures assume that the waveform has zero offset voltage.



The *peak voltage* of a waveform is the maximum absolute value of all points in the waveform. The *peak-to-peak voltage* is the difference between the maximum and minimum. The *RMS voltage* equals the standard deviation of all the points in the waveform.

The RMS value of a waveform also represents the one-cycle average power in the signal, minus the power in any DC component of the signal. *Crest factor* is the ratio of a signal's peak value to its RMS value and will differ according to waveshape. The table below shows several common waveforms with their respective crest factors and RMS values.

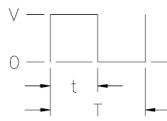
Waveform Shape	Crest Factor (C.F.)	AC RMS	AC+DC RMS
	1.414	$\frac{V}{1.414}$	$\frac{V}{1.414}$
	1.732	$\frac{V}{1.732}$	$\frac{V}{1.732}$
	$\sqrt{\frac{T}{t}}$	$\frac{V}{\text{C.F.}} \times \sqrt{1 - \left(\frac{1}{\text{C.F.}}\right)^2}$	$\frac{V}{\text{C.F.}}$

Note. *If an average-reading voltmeter is used to measure the “DC voltage” of a waveform, the reading may not agree with the DC Offset setting of the waveform generator. This is because the waveform may have a non-zero average value that would be added to the DC Offset.*

You may occasionally see AC levels specified in “decibels relative to 1 milliwatt” (dBm). Since dBm represents a power level, you will need to know the signal's RMS voltage and the load resistance in order to make the calculation.

$$\text{dBm} = 10 \times \log_{10}(P/0.001) \quad \text{where } P = V_{\text{RMS}}^2 / R_L$$

Chapter 5 Tutorial
Attributes of AC Signals

For a sine wave into a 50Ω load, the following table relates dBm to voltage.

dBm	RMS Voltage	Peak-to-Peak Voltage
+23.98 dBm	3.54 Vrms	10.00 Vpp
+13.01 dBm	1.00 Vrms	2.828 Vpp
+10.00 dBm	707 mVrms	2.000 Vpp
+6.99 dBm	500 mVrms	1.414 Vpp
3.98 dBm	354 mVrms	1.000 Vpp
0.00 dBm	224 mVrms	632 mVpp
-6.99 dBm	100 mVrms	283 mVpp
-10.00 dBm	70.7 mVrms	200 mVpp
-16.02 dBm	35.4 mVrms	100 mVpp
-30.00 dBm	7.07 mVrms	20.0 mVpp
-36.02 dBm	3.54 mVrms	10.0 mVpp
-50.00 dBm	0.707 mVrms	2.00 mVpp
-56.02 dBm	0.354 mVrms	1.00 mVpp

For 75Ω or 600Ω loads, use the following conversions.

$$\text{dBm (75}\Omega) = \text{dBm (50}\Omega) - 1.76$$

$$\text{dBm (600}\Omega) = \text{dBm (50}\Omega) - 10.79$$

Signal Imperfections

For sine waves, common signal imperfections are easiest to describe and observe in the frequency domain, using a spectrum analyzer. Any output signal component with a frequency different from the fundamental (or “carrier”) is considered to be distortion. Those imperfections can be categorized as harmonic distortion, non-harmonic spurious, or phase noise, and they are specified in decibels relative to the carrier level, or “dBc.”

Harmonic Distortion Harmonic components occur at integer multiples of the fundamental frequency and are usually created by non-linear components in the signal path. At low signal amplitudes, another possible source of harmonic distortion is the Sync signal, which is a square wave with many strong harmonic components that can couple into the main signal. Although Sync is highly isolated from the main signal outputs in the instrument, coupling can occur in external cabling. For best results, use high-quality coaxial cables with double or triple shields. If Sync is not required, leave it unconnected or turned off.

Non-Harmonic Spurious One source of non-harmonic spurious components (called “spurs”) is the digital-to-analog converter (DAC) that converts the digital representation of the waveform into voltage. Nonlinearity in this DAC gives rise to harmonics that can be higher than the Nyquist frequency (125 MHz) and will therefore be aliased to a lower frequency. For example, the 5th harmonic of 30 MHz (150 MHz) could create a spur at 100 MHz.

Another source of non-harmonic spurs is the coupling of unrelated signal sources (such as the embedded controller’s clocks) into the output signal. These spurs usually have constant amplitude and are most troublesome at signal amplitudes below 100 mVpp. For the best signal purity at low amplitudes, keep the instrument’s output level relatively high and use an external attenuator.

Phase Noise Phase noise results from small, instantaneous changes in the output frequency (“jitter”). On a spectrum analyzer, it appears as a rise in the apparent noise floor near the frequency of the output signal. The phase noise specification represents the amplitudes of the noise in 1-Hz bands located 1 kHz, 10 kHz, and 100 kHz away from a 30-MHz sine wave. Be aware that spectrum analyzers also have phase noise, so the levels you read may include analyzer phase noise.

Quantization Noise Finite resolution in the waveform DAC causes voltage quantization errors. Assuming the errors are uniformly distributed over a range of ± 0.5 least-significant bit, the equivalent noise level for standard waveforms is approximately -95 dBc. At this level, other sources of noise in the instrument dominate. Quantization noise can be of concern, though, in arbitrary waveforms that do not use the whole range of DAC codes (-32767 to +32767). Scale arbitrary waveforms to use the entire range, if possible.

Ground Loops

The signal-generation portion of the 33500 Series is isolated from chassis (earth) ground. This isolation helps eliminate ground loops in your system and also allows you to reference the output signal to voltages other than ground. The illustration below shows the waveform generator connected to a load through a coaxial cable. Any difference in ground potentials (V_{GND}) will tend to drive current I_{GND} through the shield of the cable, thus causing a voltage drop due to the shield's impedance (Z_{SHIELD}). This voltage ($I_{\text{GND}} \times Z_{\text{SHIELD}}$) appears as an error in the load voltage. However, since the instrument is isolated, there is a high series impedance (typically $>1 \text{ M}\Omega$ in parallel with 50 nF) to oppose the flow of I_{GND} and thereby minimize this effect.

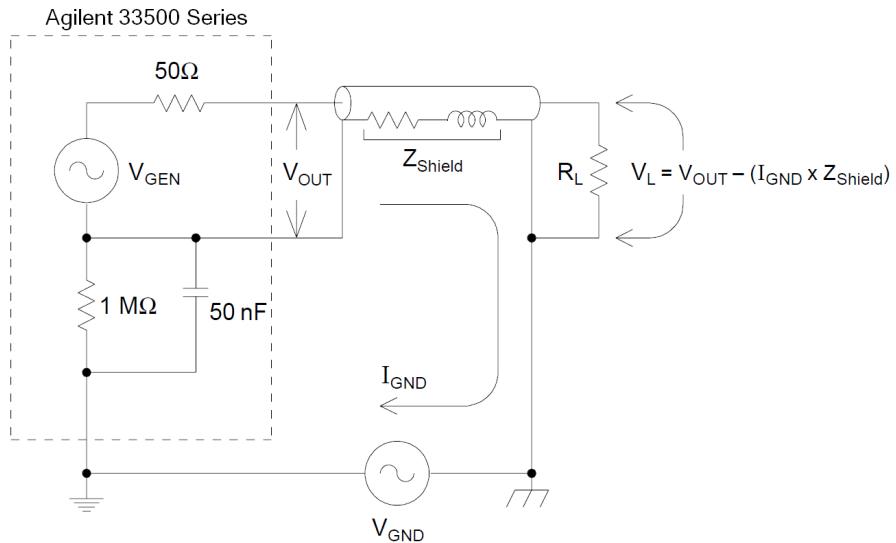

At frequencies above a few kHz, a coaxial cable's shield becomes inductive, rather than resistive, and the cable begins to act like a transformer. When this happens, voltage drops in the shield due to I_{GND} tend to be offset by equal voltages in the center conductor, thereby reducing the effects of ground loops at higher frequencies. Coaxial cables with two or three braided shields are much better than those with single-braided or foil shields because they have lower resistance and therefore become transformers at lower frequencies.

To reduce errors due to ground loops, connect the waveform generator to the load using a high-quality coaxial cable and ground it at the load through the cable's shield. If possible, make sure the waveform generator and the load are connected to the same electrical outlet to minimize further differences in ground potential.

Be aware that the outer shells of the Sync and Modulation In connectors are connected to those of the main output connector(s). Cables attached to Sync and/or Modulation In are therefore potential sources of ground loops. Also be aware that attempting to drive those connector shells to different voltages can cause high current to flow through the instrument, possibly causing damage.

Specifications

Agilent 33500 Series Function / Arbitrary Waveform Generator

The characteristics and specifications shown below are a subset of the full specifications for the 33500 Series waveform generators. For the complete set of the latest specifications, see the Web page at

www.agilent.com/find/33521A

www.agilent.com/find/33522A

INSTRUMENT CHARACTERISTICS	
MODELS AND OPTIONS	
33521A	1-Channel
33522A	2-Channel
Option 002	Increases Arbitrary Waveform memory from 1 MSa/channel to 16 MSa/channel
Option 010	High-stability frequency reference
Option 400	GPIB interface
WAVEFORMS	
Standard	Sine, Square, Ramp, Pulse, Triangle, Gaussian Noise, PRBS (Pseudorandom Binary Sequence), DC
Built-In Arbitrary	Cardiac, Exponential Fall, Exponential Rise, Gaussian Pulse, Haversine, Lorentz, Negative Ramp, Sinc
User-Defined Arbitrary	Up to 1 MSa (16 MSa with Option 002) with multi-segment sequencing
MODULATION TYPES & OPERATING MODES	
Operating Modes	Continuous, Modulate, Frequency Sweep, Burst, Output Gate
Modulation Types	AM, FM, PM, FSK, BPSK, PWM, Sum (Carrier + Modulation)
100 kHz offset:	-125 dBc/Hz -135 dBc/Hz
WAVEFORM CHARACTERISTICS	
SINE	
Frequency Range	1 μ Hz to 30 MHz, 1 μ Hz resolution
SQUARE and PULSE	
Frequency Range	1 μ Hz to 30 MHz, 1 μ Hz resolution
Rise and Fall Times (nom)	Square: 8.4 ns, fixed Pulse: 8.4 ns to 1 μ s, independently variable, 100 ps or 3-digit resolution

RAMP and TRIANGLE	
Frequency Range	1 μ Hz to 200 kHz, 1 μ Hz resolution
Ramp Symmetry	0.0% to 100.0%, 0.1% resolution (0% is negative ramp, 100% is positive ramp, 50% is triangle)
GAUSSIAN NOISE	
Bandwidth (typ)	1 mHz to 30 MHz, variable
Crest Factor (nom)	4.6
Repetition period	> 50 years
PSEUDORANDOM BINARY SEQUENCE (PRBS)	
Bit Rate	1 mbps to 50 Mbps, 1 mbps resolution
Sequence Length	2^m-1 , m=7, 9, 11, 15, 20, 23
WAVEFORM SEQUENCING	
Operation	
Individual arbitrary waveforms (segments) can be combined into user-defined lists (sequences) to form longer, more complex waveforms.	
Each sequence step specifies whether to repeat the associated segment a certain number of times, to repeat it indefinitely, to repeat it until a Trigger event occurs, or to stop and wait for a Trigger event.	
Additionally, the behavior of the Sync output can be specified in each step.	
To improve throughput, up to 32 sequences totaling of up to 1024 segments can be pre-loaded into volatile memory.	
Segment Length	8 Sa to 1 MSa (16 MSa with Option 002) in increments of 1
Sequence Length	1 to 512 steps
Segment Repeat Count	1 to 1,000,000 or Infinite

OUTPUT CHARACTERISTICS	
ISOLATION	
Outputs	Connector shells for Ch 1, Ch2, Sync, and Mod In are connected together but isolated from the instrument's chassis. Maximum allowable voltage on isolated connector shells is ± 42 Vpk.
SIGNAL OUTPUT	
Output Impedance (nom)	50 Ω
On, Off, Inverted	User-selectable for each channel
Voltage Limit	User-definable V_{MAX} and V_{MIN} safety limits
Overload Protection	Output turns off automatically when an overload is applied. Instrument will tolerate a short circuit to ground indefinitely.
FREQUENCY ACCURACY	
STANDARD (spec)	
1 Year 23°C \pm 5 °C	± 1 ppm of setting \pm 15 pHz
1 Year 0°C to 55°C	± 2 ppm of setting \pm 15 pHz
OPTION 010 (spec)	
1 Year 0°C to 55°C	± 0.1 ppm of setting \pm 15 pHz

MODULATION TYPES AND OPERATING MODES									
CARRIER	AM	FM	PM	FSK	BPSK	PWM	Sum	Burst	Sweep
SINE and SQUARE	•	•	•	•	•		•	•	•
PULSE	•	•	•	•	•	•	•	•	•
TRIANGLE and RAMP	•	•	•	•	•		•	•	•
GAUSSIAN NOISE	•						•	• ^(a)	
PRBS	•	•	•				•	•	
SINGLE ARB	•		• ^(b)		• ^(b)		•	•	
SEQUENCED ARB	•						•		

(a) Gated burst only

(b) Applies to sample clock, not whole waveform

MODULATING SIGNAL							
CARRIER	Sine	Square	Triangle/ Ramp	Gaussian Noise	PRBS	ARB	External
SINE	•	•	•	•	•	•	•
SQUARE and PULSE	•	•	•	•	•	•	•
TRIANGLE and RAMP	•	•	•	•	•	•	•
GAUSSIAN NOISE	•	•	•		•	•	•
PRBS	•	•	•	•		•	•
ARB	•	•	•	•	•		•

MODULATION CHARACTERISTICS	
AMPLITUDE MODULATION (AM)	
Source	Internal or External, or either channel with 33522A
Type	Double-Sideband, Suppressed Carrier or Full Carrier
Depth ^[1]	0% to 120%, 0.01% resolution
FREQUENCY MODULATION (FM)^[2]	
Source	Internal or External, or either channel with 33522A
Deviation	DC to 15 MHz, 1-μHz resolution
PHASE MODULATION (PM)	
Source	Internal or External, or either channel with 33522A
Deviation	0° to 360°, 0.1° resolution
FREQUENCY SHIFT KEY MODULATION (FSK)^[2]	
Source	Internal Timer or <i>Ext Trig</i> connector
Mark & Space	Any frequency within the carrier signal's range
Rate	DC to 1 MHz
BINARY PHASE SHIFT KEY MODULATION (BPSK)	
Source	Internal Timer or <i>Ext Trig</i> connector
Phase Shift	0° to 360°, 0.1° resolution
Rate	DC to 1 MHz
PULSE WIDTH MODULATION (PWM)	
Source	Internal or External, or either channel with 33522A
Deviation ^[3]	0% to 100% of Pulse Width, 0.01% resolution
ADDITIVE MODULATION (Sum)	
Source	Internal or External, or either channel with 33522A
Ratio	0% to 100% of carrier amplitude, 0.01% resolution
BURST^[4]	
Type	Counted or Gated
Count	1 to 100,000,000 cycles, or infinite
Gated	Produces complete cycles while <i>Ext Trig</i> is asserted
Start/Stop Phase	-360° to 360°, 0.1° resolution
Trigger Source	Internal Timer or <i>Ext Trig</i> connector
Marker	Adjustable to any cycle; indicated by the trailing edge of the Sync pulse

SWEEP ^[2]	
Type	Linear, Logarithmic, List (up to 128 user-defined frequencies)
Operation	Linear and Logarithmic sweeps are characterized by a Sweep time (during which the frequency changes smoothly from Start to Stop), a Hold time (during which the frequency stays at the Stop frequency), and a Return time (during which the frequency changes linearly from Stop to Start).
Direction	Up (Start freq < Stop freq) or Down (Start freq > Stop freq)
Start & Stop Frequencies	Any frequency within the waveform's range.
Sweep Time (except IMM trigger mode)	Linear: 1 ms to 3600 s, 1 ms resolution; 3601 s to 250,000 s, 1 s resolution
Sweep Time for IMM trigger	Linear: 1 ms to 3600 s, 1 ms resolution; 3601 s to 8,000 s, 1 s resolution
Sweep Time	Logarithmic: 1 ms to 500 s
Hold Time	0 s to 3600 s, 1 ms resolution
Return Time	0 s to 3600 s, 1 ms resolution
Trigger Source	Immediate (continuous), External, Single, Bus, or Timer
Marker	Adjustable to any frequency between Start and Stop for Linear and Logarithmic types or any frequency in the list for List type; indicated by the trailing edge of the Sync pulse
INTERNAL TIMER FOR FSK, BPSK, BURST, AND SWEEP	
Range	1 μs to 8,000 s, 6-digit or 4-ns resolution
2-CHANNEL CHARACTERISTICS (33522A ONLY)	
Operating Modes	<ul style="list-style-type: none"> • Independent • Coupled Parameter(s) • Combined (Ch1+Ch2) • Equal (Ch2 = Ch1) • Differential (Ch2 = -Ch1)
Parameter Coupling	<ul style="list-style-type: none"> • None • Frequency (Ratio or Difference) • Amplitude & DC Offset
Relative Phase	0 degrees to 360 degrees, 0.1 degrees resolution

- [1] Subject to maximum output voltage limits.**
[2] All frequency changes are phase-continuous.
[3] Subject to pulse width limits.
[4] The maximum Sine-wave frequency for counted and gated burst is 10 MHz unless Burst Count is set to "Infinite". Counted Burst operation is not allowed for Gaussian Noise.



SYNC / MARKER OUTPUT

Connector	Front-panel BNC, isolated from chassis
Functions	Sync, Sweep Marker, Burst Marker, or Arbitrary Waveform Marker
Assignment	Channel 1 or Channel 2
Polarity	Normal or Inverted
Voltage Level (nom)	3 Vpp into open circuit, 1.5 Vpp into 50 Ω
Output Impedance (nom)	50 Ω
Min. Pulse Width (nom)	16 ns

MODULATION INPUT

Connector	Rear-panel BNC, isolated
Assignment	Channel 1, Channel 2, or Both
Voltage Level	± 5 V full-scale
Input Impedance (nom)	5 k Ω
Bandwidth (-3 dB typ)	DC to 100 kHz

FREQUENCY REFERENCE INPUT

Connector	Rear-panel BNC, isolated from chassis and all other connectors
Reference Selection	Internal, External, or Auto
Frequency Range	Standard: 10 MHz \pm 20 Hz Option 010: 10 MHz \pm 1 Hz
Lock Time (typ)	<2 s
Voltage Level	200 mVpp to 5 Vpp
Input Impedance (nom)	1 k Ω 20 pF, AC-coupled

FREQUENCY REFERENCE OUTPUT

Connector	Rear-panel BNC, chassis-referenced
Output Impedance (nom)	50 Ω , AC-coupled
Level (nom)	0 dBm, 632 mVpp

REAL-TIME CLOCK / CALENDAR

Set and Read	Year, Month, Day, Hour, Minute, Second
Battery	CR-2032 coin-type, replaceable, >5-year life (typ)

Agilent 33500 Series Function / Arbitrary Waveform Generator

MEMORY	
ARBITRARY WAVEFORM MEMORY	
Volatile	1M samples / ch 512 Sequence steps / ch Optional 16M point / ch
Non-Volatile	File system file space is limited to 64 MB (approximately 32 MSA of arbitrary waveform records).
INSTRUMENT STATE	
Store / Recall	User defined instrument states
Power Off	Power Off state automatically saved
Power On	Selectable Reset, Power Off, or User State
USB File System	
Front-panel port	USB 2.0 high-speed mass storage (MSC) class device
Capability	Read or Write instrument configuration settings, instrument states, and User Arbitrary waveform and sequence files.
Speed	10 MB/s (nominal)
GENERAL CHARACTERISTICS	
COMPUTER INTERFACES	
LXI-C (rev 1.3)	10/100Base-T Ethernet (Sockets & VXI-11 protocol) USB 2.0 (USB-TBC488 protocol) GPIB/IEEE-488.1, IEEE-488.2
Web User Interface	Remote operation and monitoring
Programming Language	SCPI-1999, IEEE-488.2 Agilent 33210A / 33220A compatible
Graphical Display	4.3" Color TFT WQVGA (480x272) with LED backlight
MECHANICAL	
Size	261.1mm W x 103.8mm H x 303.2mm D (with bumpers installed) 212.8mm W x 88.3mm H x 272.3mm D (with bumpers removed) 2U x 1/2-width
Weight	33521A: 3.2 kg (7.1 lbs.) 33522A: 3.3 kg (7.2 lbs.)

ENVIRONMENTAL	
Storage Temperature	-40° C to 70° C
Warm-Up Time	1 hour
Operating Environment	EN61010, Pollution Degree 2; Indoor Locations
Operating Temperature	0 °C to 55 °C
Operating Humidity	5% to 80% RH, non-condensing
Operating Altitude	up to 3000 meters
REGULATORY	
Safety	CAT II (300V), EN61010
EMC	EN55011, EN50082-1, MIL-461C
Vibration & Shock	MIL-T-28800, Type III, Class 5
Acoustic Noise	35 dB(A)
LINE POWER	
Voltage	100 V - 240 V 50/60 Hz -5%, +10% 100 V - 120 V 400 Hz ± 10%
Power Consumption (typ)	< 45 W, < 130 VA
WARRANTY	
1 year standard, 3 years optional	

Note: Specifications are subject to change without notice. For the latest specifications, go to the Agilent 33521A or Agilent 33522A product page for the latest datasheet.

www.agilent.com/find/33521A

www.agilent.com/find/33522A

This ISM device complies with Canadian ICES-001.

Cet appareil ISM est conforme à la norme NMB-001 du Canada.



Chapter 6 Specifications
Agilent 33500 Series Function / Arbitrary Waveform Generator

Product Dimensions

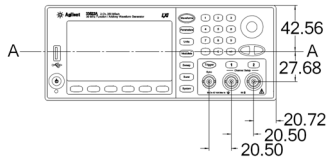
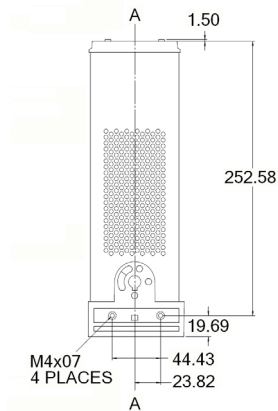
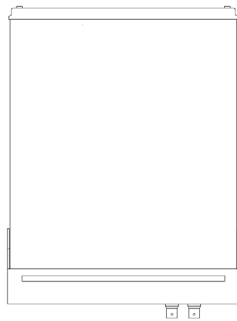
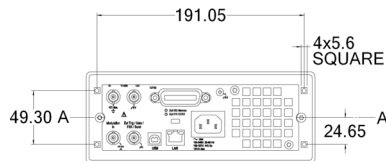
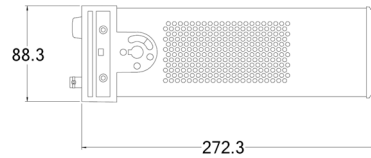
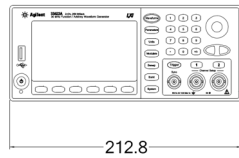
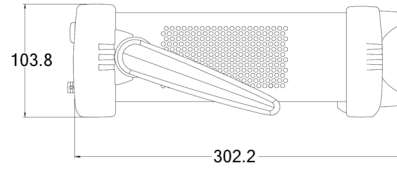
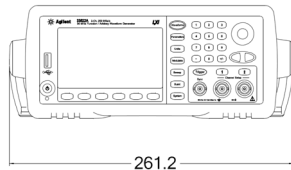

All dimensions are shown in millimeters.

Index

If you have questions relating to the operation of the Agilent 33500 Series, call 1-800-829-4444 in the United States, or contact your nearest Agilent Technologies Office.

Numerics

10 MHz In connector 187
10 MHz Out connector 187
33220A overview 6

A

ac connector 10
address
 GPIB 65, 178, 179
Agilent Express 11
air flow 39
AM 114

 carrier frequency 115
 carrier waveform 115
 front-panel operation 49
 modulating source 118
 modulating waveform 116
 modulation depth 117
amplitude 22
 arb waveform limitations 97
 effect of load impedance 101
 load limitations 96
 offset limitations 96
 range hold 105
 unit limitations 96
 units 100
amplitude modulation 114, 119

 carrier frequency 115
 carrier waveform 115
 front-panel operation 49
 modulating source 118
 modulating waveform 116
 modulation depth 117
application programs 217
autoranging, amplitude 105

B

beeper 170
blank display 170
BNC
 Modulation In 118, 124, 133, 142
brightness, display 171, 174
built-in help system 35
bulb-saver mode 170
Burst 156
burst 152
 burst count 156
 burst period 157
 burst phase 158
 burst type 153
 external gated mode 153
 external trigger source 165
 front-panel operation 59
 gated burst 252
 n-cycle burst 251

 starting phase 251
 trigger out signal 160
 trigger output 166
 trigger source 159
 triggered mode 153
 waveform frequency 155

bus

 interface configuration 65, 178
bus trigger 163

C

calibration
 message 193
 read count 192
 security code 190
calibration certificate 17
carrying handle
 changing positions 19
CD-ROM, connectivity software 17
CD-ROM, shipped with 33220A 218
chassis ground 10
comma separator 175
command errors 169
configuration
 GPIB 65, 178
 LAN 65, 178, 185
 remote interface 65, 178

-
- USB 65, 66, 178
 - connector
 - 10 MHz In 187
 - 10 MHz Out 187
 - Modulation In 118, 124, 133, 142
 - Sync Output 107
 - Trig In 165
 - Trig Out 166
 - context-sensitive help 35
 - copy files 172
 - count
 - burst 156
 - crest factor 254
 - cycle count
 - burst 156
 - D**
 - date 171
 - dBm 100, 255
 - dc offset
 - amplitude limitations 98
 - arb waveform limitations 99
 - front-panel selection 25
 - load limitations 98
 - dc voltage
 - front-panel selection 25
 - decimal point 175
 - default settings 215
 - delete files 172
 - deviation (FM) 123
 - DHCP 70
 - DHCP On/Off 180
 - digits separator 175
 - dimensions
 - product 268
 - display 171, 174
 - brightness 171, 174
 - bulb saver mode 170
 - displaying message 174
 - enable / disable 174
 - number format 175
 - overview 8
 - DNS server 184
 - domain name 184
 - dot notation
 - and IP addresses 72
 - duty cycle 103
 - definition 103
 - frequency limitations 95, 103
 - E**
 - edge time, pulse 32, 113
 - errors 169
 - examples
 - programming 217
 - external gated burst 153
 - external reference 187
 - external source
 - AM 118
 - FM 124
 - FSK 133
 - PM 129, 137
 - PWM 142
 - external timebase 187
 - external trigger 163
 - external trigger source 165, 166
 - F**
 - file
 - copy 172
 - delete
 - file
 - rename 172
 - file management 172
 - firmware revision 176
 - FM 119
 - carrier frequency 121
 - carrier waveform 120
 - frequency deviation 123
 - modulating frequency 122
 - modulating source 124
 - modulating waveform 122
 - frequency
 - burst limitation 95
 - duty cycle limitations 95
 - front-panel selection 20
 - function limitations 95
-

-
- sweep time 141, 146, 147
 - frequency deviation (FM) 123
 - frequency modulation
 - carrier frequency 121
 - carrier waveform 120
 - frequency deviation 123
 - modulating frequency 122
 - modulating source 124
 - modulating waveform 122
 - frequency sweep 143
 - center frequency 145
 - external trigger source 165
 - frequency span 145
 - front-panel operation 53, 56
 - linear vs. logarithmic 141, 146, 147
 - marker frequency 148
 - spacing 141, 146, 147
 - start frequency 144
 - stop frequency 144
 - Sync signal 144
 - trigger out signal 150
 - trigger output 166
 - trigger source 149
 - frequency sweeps
 - Sync signal 145
 - frequency-shift keying
 - See FSK 51
 - see FSK
 - front panel
 - connectors 7
 - display overview 8
 - number entry 9
 - overview 7
 - front-panel
 - display enable/disable 174
 - number format 175
 - front-panel configuration
 - LAN 67
 - front-panel menu operation 41
 - front-panel selection 22
 - FSK 130
 - front-panel operation 51
 - FSK rate 52, 132
 - hop frequency 51, 132
 - modulating source 133
 - rate 133
 - FSK rate 52, 133
 - function
 - allowed with modulation 92
 - amplitude limitations 93
 - frequency limitations 93
 - G**
 - gated burst 153, 252
 - gateway address 182
 - GPIB
 - address 65, 178, 179
 - configuration 65
 - connector 10
 - default address 65
 - front-panel configuration 65
 - setting address 65
 - GPIB configuration 65, 178
 - H**
 - handle
 - changing positions 19
 - help system 35
 - high impedance load 101
 - high level
 - setting 27
 - high Z load 47, 101
 - hold time 147
 - hop frequency 51
 - hop frequency (FSK) 132
 - host name 183
 - I**
 - IEEE-488
 - address 65, 178
 - connector 10
 - default address 65

front-panel configuration 65
 setting address 65
impedance
 effect on amplitude 101
impedance, load 47
instrument errors 169
instrument overview 6
instrument reset 48
instrument self test 171, 174
instrument specifications 261
instrument state storage 167
instrument states
 naming from front panel 63
 storing from front-panel 63
interface
 web 186
interface (bus) trigger 163
interface configuration 65, 178
interface errors 169
internal trigger 162
invert waveform 106
IP address 181
 dot notation 72
 further information 72

L
LAN
 Configuration 179
 configuration 185
 connector 10
 DHCP 180
 DNS server 184
 domain name 184
 front-panel configuration 67
 gateway 182
 host name 183
 IP address 181
 reset 179
 setting address 67
 subnet mask 182
LAN configuration 65, 178
LCD display 8
 bulb-saver mode 170
load 47, 101
load impedance
 effect on amplitude 101
load termination 47
 effect on amplitude 101
low level
 setting 27

M
MAC address 185
manage files 172
manual trigger 162
marker frequency 148
menu operation 41
message
 calibration 193
modulation 49, 130
 AM 114
 FM 119
 FSK 130
 PM 125
 PWM 134
modulation depth (AM) 117
modulation depth, percent
modulation 49
Modulation In connector 118, 124, 133, 142
modulation source
 AM 118
 FM 124
 FSK 133
 PM 129, 137
 PWM 142

-
- N**
naming stored states
 front-panel operation 63
n-cycle burst 251
new folder 172
number entry 9
number keypad 9
numeric entry 9
- O**
offset
 amplitude limitations 98
 arb waveform limitations 99
 front-panel selection 25
 load limitations 98
output
 connector 105
 enable/disable 105
 polarity 106
output amplitude
 arb waveform limitations 97
 front-panel selection 22
 load limitations 96
 offset limitations 96
 range hold 105
 unit limitations 96
 units 100
output frequency
 burst limitations 95
 duty cycle limitations 95
 front-panel selection 20
 function limitations 95
output function
 allowed with modulation 92
 amplitude limitations 93
 frequency limitations 93
output impedance
 effect on amplitude 101
output load 101
output period
 front-panel selection 20
output resistance 47
output termination 47, 101
 effect on amplitude 101
output units 100
output waveform
 polarity 106
overheating 39
overload, voltage 105
overview
 display 8
 front panel 7
 number entry 9
 product 6
 rear panel 10
- P**
password, calibration 190
peak frequency deviation (FM) 123
peak voltage 254
peak-to-peak voltage 254
percent modulation (AM) 117
period
 burst mode 157
 front-panel selection 20
 pulse waveform 110
phase (burst) 158
PHASe command 187
phase lock 187
 phase offset 187
phase modulation
 carrier frequency 126
 carrier waveform 126
 modulating source 129, 137
 modulating waveform 127, 135
 phase deviation 128, 136
phase offset
 phase lock 187
PM 127, 135
 carrier frequency 126
 carrier waveform 126
 modulating source 129, 137
 modulating waveform 127, 135
modulation 125
-

-
- phase deviation 128, 136
 - polarity 106
 - polarity, waveform 106
 - power connector 10
 - power cord 17
 - power switch 17
 - product dimensions 268
 - product overview 6
 - product specifications 261
 - programming examples 217
 - pulse
 - front-panel configuration 32
 - pulse edge time 113
 - pulse waveform
 - pulse period 110
 - pulse width 32, 111, 112
 - pulse width modulation 134
 - modulating source 142
 - pulse waveform 138
 - PWM 134
 - modulating source 142
 - modulation source 142
 - pulse waveform 138
 - Q**
 - queue, error 169
 - quick start 15
 - R**
 - rack mounting kits 39
 - ramp waveform
 - symmetry 104
 - range hold, amplitude 105
 - rear panel
 - connectors 10
 - overview 10
 - reference, external 187
 - remote (bus) trigger 163
 - remote errors 169
 - remote interface
 - configuration 65, 178
 - rename files 172
 - reset 48
 - LAN 179
 - resistance, load 47
 - revision, firmware 176
 - RMS voltage 254
 - root-mean-square 254
 - S**
 - safety notices 3
 - SCPI version 176
 - screen 8
 - displaying message 174
 - number format 175
 - screen blank 170
 - screen brightness 171, 174
 - screen enable / disable 174
 - screen saver mode 170
 - security
 - calibration 190
 - self test 171, 174
 - self-test 173
 - setting address
 - LAN 67
 - settings
 - default 215
 - shipping contents 17
 - shock hazard 10
 - slope, trigger
 - burst 159
 - sweep 149
 - softkey labels 8
 - software (bus) trigger 163
 - software revision 176
 - software, connectivity 17
 - sound (beeper) 170
 - specifications 261
 - square wave
 - duty cycle 103
 - starting phase, burst 158
 - state storage 167
 - front-panel operation 63
 - naming from front panel 63
 - stored states 167
 - front-panel operation 63
 - naming from front panel 63
 - subnet mask 182

-
- support, technical 11
 - sweep 143
 - center frequency 145
 - external trigger source 165
 - frequency span 145
 - front-panel operation 53, 56
 - linear vs. logarithmic 141, 146, 147
 - marker frequency 148
 - spacing 141, 146, 147
 - start frequency 144
 - stop frequency 144
 - sweep time 141, 146, 147
 - Sync signal 144
 - trigger out signal 150
 - trigger output 166
 - trigger source 149
 - sweps
 - Sync signal 145
 - symmetry 104
 - symmetry definition 104
 - sync signal
 - enable/disable 109
 - for all waveform functions 107
 - Sync connector 107
 - system date 171
 - system error 169
 - system time 171
 - T**
 - technical support 11
 - phone numbers 3
 - Web site 3
 - temperature overload 39
 - terminal
 - 10 MHz In 187
 - 10 MHz Out 187
 - Modulation In 118, 124, 133, 142
 - Sync Output 107
 - Trig In 165
 - Trig Out 166
 - termination 47, 101
 - effect on amplitude 101
 - test 171, 174
 - text message
 - calibration 193
 - time 171
 - timebase, external 187
 - Trig In connector 165
 - Trig Out connector 166
 - trigger
 - burst 159
 - sweep 149
 - trigger out signal (burst) 160
 - trigger out signal (sweep) 150
 - trigger slope
 - burst 159
 - sweep 149
 - triggering
 - burst 160
 - external source 163
 - front-panel operation 62
 - internal source 162
 - manual source 162
 - software (bus) source 163
 - sweep 150
 - Trig In connector 165
 - Trig Out connector 166
 - trigger sources 161
 - tutorial 243
 - U**
 - units
 - amplitude 100
 - USB
 - configuration 65, 66, 178
 - connector 10
 - USB Configuration 186

V

version, SCPI 176
voltage autorange 105
voltage overload 105
voltage units 100
vpp 100
vrms 100

W

warranty 2
waveform invert 106
waveform output
 connector 105
 enable/disable 105
 polarity 106
waveform polarity 106
waveform tutorial 243
web
interface 186