

IP CORE MANUAL



AXI4-Stream Folded Symmetrical Decimation FIR Filter IP

px_axis_fdecfir32_1

PENTEK

Pentek, Inc.
One Park Way
Upper Saddle River, NJ 07458
(201) 818-5900
<http://www.pentek.com/>

Copyright © 2016

Manual Revision History

<u>Date</u>	<u>Version</u>	<u>Comments</u>
12/09/16	1.0	Initial Release

Legal Notices

The information disclosed to you hereunder (the “Materials”) is provided solely for the selection and use of Pentek products. To the maximum extent permitted by applicable law: (1) Materials are made available “AS IS” and with all faults, Pentek hereby DISCLAIMS ALL WARRANTIES AND CONDITIONS, EXPRESS, IMPLIED, OR STATUTORY, INCLUDING BUT NOT LIMITED TO WARRANTIES OF MERCHANTABILITY, NON-INFRINGEMENT, OR FITNESS FOR ANY PARTICULAR PURPOSE; and (2) Pentek shall not be liable (whether in contract or tort, including negligence, or under any other theory of liability) for any loss or damage of any kind or nature related to, arising under, or in conjunction with, the Materials (including your use of Materials), including for any direct, indirect, special, incidental, or consequential loss or damage (including loss of data, profits, goodwill, or any type of loss or damage suffered as a result of any action brought by a third party) even if such damage and loss was reasonably foreseeable or Pentek had been advised of the possibility of the same. Pentek assumes no obligation to correct any error contained in the Materials or to notify you of updates to the Materials or to product specifications. You may not reproduce, modify, distribute, or publicly display the materials without prior written consent. Certain products are subject to the terms and conditions of Pentek’s limited warranty, please refer to Pentek’s Ordering and Warranty information which can be viewed at <http://www.pentek.com/contact/customerinfo.cfm>; IP cores may be subject to warranty and support terms contained in a license issued to you by Pentek. Pentek products are not designed or intended to be fail-safe or for use in any application requiring fail-safe performance; you assume sole risk and liability for the use of Pentek products in such critical applications.

Copyright

Copyright © 2016, Pentek, Inc. All Rights Reserved. Contents of this publication may not be reproduced in any form without written permission.

Trademarks

Pentek, Jade, and Navigator are trademarks or registered trademarks of Pentek, Inc.

ARM and AMBA are registered trademarks of ARM Limited. PCI, PCI Express, PCIe, and PCI-SIG are trademarks or registered trademarks of PCI-SIG. Xilinx, Kintex UltraScale, Vivado, and Platform Cable USB are registered trademarks of Xilinx Inc., of San Jose, CA.

Table of Contents

		<i>Page</i>
<i>IP Facts</i>		
Description.....		7
Features.....		7
Table 1-1: IP Facts Table.....		7
 <i>Chapter 1: Overview</i> 		
1.1	Functional Description	9
	Figure 1-1: AXI4-Stream Folded Symmetrical Decimation FIR Filter Core Block Diagram	9
1.2	Applications.....	10
1.3	System Requirements	10
1.4	Licensing and Ordering Information	10
1.5	Contacting Technical Support	11
1.6	Documentation.....	11
 <i>Chapter 2: General Product Specifications</i> 		
2.1	Standards	13
2.2	Performance.....	13
	2.2.1 Maximum Frequencies	13
2.3	Resource Utilization	13
	Table 2-1: Resource Usage and Availability.....	13
2.4	Limitations and Unsupported Features.....	14
2.5	Generic Parameters.....	14
	Table 2-2: Generic Parameters	14
 <i>Chapter 3: Port Descriptions</i> 		
3.1	AXI4-Lite Core Interfaces.....	15
	3.1.1 Control/Status Register (CSR) Interface	15
	Table 3-1: Control/Status Register (CSR) Interface Port Descriptions	15
3.2	AXI4-Stream Core Interfaces.....	18
	3.2.1 Combined Sample Data/ Timestamp/ Information Streams (PDTI) Interfac	18
	Table 3-2: Combined Sample Data/ Timestamp/ Information Stream Interface Port Descriptions.....	18
3.3	I/O Signals	20
	Table 3-3: I/O Signals.....	20

Table of Contents

 Page

Chapter 4: Register Space

	Table 4-1: Register Space Memory Map	21
4.1	Decimation Register.....	22
	Figure 4-1: Decimation Register	22
	Table 4-2: Decimation Register (Base Address + 0x0000).....	22
4.2	Gain Register.....	23
	Figure 4-2: Gain Register	23
	Table 4-3: Gain Register (Base Address + 0x0004).....	23
4.3	Control Register	24
	Figure 4-3: Control Register	24
	Table 4-4: Control Register (Base Address + 0x0008).....	24
4.4	Coefficient Load Register	25
	Figure 4-4: Coefficient Load Register	25
	Table 4-5: Coefficient Load Register (Base Address + 0x000C).....	25
4.5	Status Register.....	26
	Figure 4-5: Status Register.....	26
	Table 4-6: Status Register (Base Address + 0x0010)	26
4.6	Interrupt Enable Register	27
	Figure 4-6: Interrupt Enable Register	27
	Table 4-7: Interrupt Enable Register (Base Address + 0x0014).....	27
4.7	Interrupt Status Register.....	28
	Figure 4-7: Interrupt Status Register.....	28
	Table 4-8: Interrupt Status Register (Base Address + 0x0018)	28
4.8	Interrupt Flag Register	29
	Figure 4-8: Interrupt Flag Register.....	29
	Table 4-9: Interrupt Flag Register (Base Address + 0x001C)	29
4.9	Coefficient RAM Space	30

Chapter 5: Designing with the Core

5.1	General Design Guidelines	31
5.2	Clocking	31
5.3	Resets	31
5.4	Interrupts	31
5.5	Interface Operation.....	32
5.6	Programming Sequence	32
5.7	Timing Diagrams	33

Table of Contents

		<i>Page</i>
Chapter 6: Design Flow Steps		
	Figure 6-1: AXI4-Stream Folded Symmetrical Decimation FIR Filter Core in Pentek IP Catalog..	35
	Figure 6-2: AXI4-Stream Folded Symmetrical Decimation FIR Filter Core IP Symbol	36
6.2	User Parameters	36
6.3	Generating Output	36
6.4	Constraining the Core	37
6.5	Simulation.....	37
	Figure 6-3: AXI4-Stream Folded Symmetrical Decimation FIR Filter Core Test Bench	
	Simulation Output	38
6.6	Synthesis and Implementation.....	39

Table of Contents

Page

This page is intentionally blank

IP Facts

Description

Pentek's Navigator™ AXI4-Stream Folded Symmetrical Decimation FIR Filter Core is as a symmetrical decimating FIR filter which can perform decimations in the order of 2 to 32 on the input AXI4-Streams from the user design.

This core complies with the ARM® AMBA® AXI4 Specification and also provides a control/status register interface. This user manual defines the hardware interface, software interface, and parameterization options for the AXI4-Stream Folded Symmetrical Decimation FIR Filter Core.

Features

- Software programmable output resolution and number of channels
- Register access through AXI4-Lite Interface
- Adjustable gain of the filter output
- Supports synchronization of decimation of FIR with the sync signal in the input AXI4-Stream sideband user data

Table 1-1: IP Facts Table	
Core Specifics	
Supported Design Family ^a	Kintex® Ultrascale
Supported User Interfaces	AXI4-Lite and AXI4-Stream
Resources	See Table 2-1
Provided with the Core	
Design Files	VHDL
Example Design	Not Provided
Test Bench	VHDL
Constraints File	Not Provided ^b
Simulation Model	VHDL
Supported S/W Driver	HAL Software Support
Tested Design Flows	
Design Entry	Vivado® Design Suite 2016.3 or later
Simulation	Vivado VSim
Synthesis	Vivado Synthesis
Support	
Provided by Pentek fpgasupport@pentek.com	

a.For a complete list of supported devices, see the [Vivado Design Suite Release Notes](#).

b.Clock constraints can be applied at the top level module of the user design.

This page is intentionally blank

Chapter 1: Overview

1.1 Functional Description

The AXI4-Stream Folded Symmetrical Decimation FIR Filter Core implements an FIR Filter with the maximum number of filter taps equivalent to 28 times the decimation value, in order to perform filtering and decimation of the input AXI4-Stream. It includes a Xilinx Dual Port RAM where the filter coefficients are written to, and read from, using the Pentek Block RAM Controller Core. The filter accepts only symmetrical coefficient set with even number of filter taps.

The core adjusts the gain of the filter output to a value defined by the user through the control registers within the Register Space. The FIR Filter Core (AXI4-Stream Folded Symmetrical Decimation FIR Filter Core) also performs rounding and saturation operations of the output AXI Streams. The decimation of the FIR filter can be synchronized to the sync signal in the sideband user information of the input AXI4-Stream. The decimation rate and output resolution of the FIR filter can be defined by the user through the generic parameters as described in [Section 2.5](#).

[Figure 1-1](#) is a top-level block diagram of the Pentek AXI4-Stream Folded Symmetrical Decimation FIR Filter Core. The modules within the block diagram are explained in the later sections of this manual.

Figure 1-1: AXI4-Stream Folded Symmetrical Decimation FIR Filter Core Block Diagram

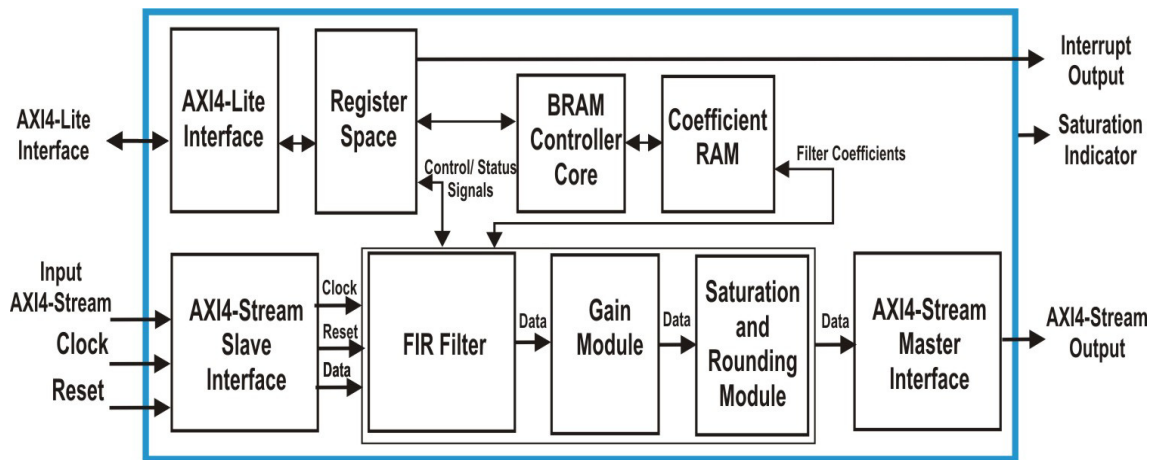

1.1 Functional Description (continued)

- ❑ **AXI4-Stream Interface:** The AXI4-Stream Decimation FIR Filter Core has two AXI4-Stream Interfaces. At the input, an AXI4-Stream Slave Interface is used to receive AXI4-Streams and at the output an AXI4-Stream Master Interface is used to transfer AXI4-Streams through the output ports. For more details about the AXI4-Stream Interfaces please refer to [Section 3.2 AXI4-Stream Core Interfaces](#).
- ❑ **AXI4-Lite Interface:** This core implements a 32-bit AXI4-Lite Slave Interface to access the Register Space. For additional details about the AXI4-Lite Interface, refer to [Section 3.1 AXI4-Lite Core Interfaces](#).
- ❑ **Register Space:** This module contains the control and status registers of the core. These registers are accessed through the AXI4-Lite Interface.
- ❑ **FIR Filter:** This block is the FIR filter implemented by the core to generate filter output at the desired decimation rate.
- ❑ **Gain Module:** This module adjusts the gain of the filter output to a value defined by the user in the Gain Register of the core.
- ❑ **Saturation and Rounding Module:** This module performs saturation and rounding of the filter output data based on the output resolution defined by the user.
- ❑ **BRAM Controller Core:** This is the Pentek AXI4-Lite Block RAM Controller Core used to access the Coefficient Block RAM of the core through the AXI4-Lite Interface. The Coefficient Block RAM stores the filter coefficients.
- ❑ **Coefficient Block RAM:** This is a Xilinx Dual Port RAM included within the FIR Filter Core to store the filter coefficients. The filter coefficients of FIR Filter Core are 18 bits wide.

1.2 Applications

The AXI4-Stream Folded Symmetrical Decimation FIR Filter Core can be incorporated into any Kintex Ultrascale FPGA to perform decimation and filtering of AXI4-Streams.

1.3 System Requirements

For a list of system requirements, see the [Vivado Design Suite Release Notes](#).

1.4 Licensing and Ordering Information

This core is included with all Pentek Navigator FPGA Design Kits for Pentek Jade series board products. Contact Pentek for Licensing and Ordering Information (www.pentek.com).

1.5 Contacting Technical Support

Technical Support for Pentek's Navigator FPGA Design Kits is available via e-mail (fpgasupport@pentek.com) or by phone (201-818-5900 ext. 238, 9 am to 5 pm EST).

1.6 Documentation

This user manual is the main document for this IP core. The following documents provide supplemental material:

- 1) *Vivado Design Suite User Guide: Designing with IP*
- 2) *Vivado Design Suite User Guide: Programming and Debugging*
- 3) *ARM AMBA AXI4 Protocol Version 2.0 Specification*
<http://www.arm.com/products/system-ip/amba-specifications.php>

This page is intentionally blank

Chapter 2: General Product Specifications

2.1 Standards

The AXI4-Stream Folded Symmetrical Decimation FIR Filter Core has bus interfaces that comply with the [ARM AMBA AXI4-Lite Protocol Specification](#) and the [AMBA AXI4-Stream Protocol Specification](#).

2.2 Performance

The performance of the FIR Filter Core is limited only by the FPGA logic speed. The values presented in this section should be used as an estimation guideline. Actual performance can vary.

2.2.1 Maximum Frequencies

The FIR Filter Core has two incoming clock signals. The AXI4-Stream clock, and the AXI4-Lite Interface CSR clock, both have maximum frequencies of 250 MHz on a Kintex Ultrascale -2 speed grade FPGA. 250 MHz is typically the PCI Express (PCIe®) AXI bus clock frequency.

2.3 Resource Utilization

The resource utilization of the FIR Filter Core is shown in [Table 2-1](#). Resources have been estimated for the Kintex Ultrascale XCKU060 -2 speed grade device. These values were generated using the Vivado Design Suite.

Resource	# Used
LUTs	2283
Flip-Flops	4880
Memory LUTs	1578
DSP	34

NOTE: Actual utilization may vary based on the user design in which the FIR Filter Core is incorporated.

2.4 Limitations and Unsupported Features

- ❑ The FIR filter supports only symmetrical coefficient set with even length.

2.5 Generic Parameters

The generic parameters of the FIR Filter Core are described in [Table 2-2](#). These parameters can be set as required by the user application while customizing the core.

Table 2-2: Generic Parameters		
Port/Signal Name	Type	Description
out_res	Integer	Output Resolution: This parameter indicates the width of the real/ imaginary data in the output data stream. It can take only two values, 16 or 24.
num_chan		Number of Channels: This parameter indicate the type of input data stream. 1 = Real Data Stream 2 = Complex IQ Data Stream
bypass_in_lower	Boolean	Bypass in Lower: This parameter when set to True, bypasses the data in the lower bits of output data rather than the upper 16 bits.

Chapter 3: Port Descriptions

This chapter provides details about the port descriptions for the following interface types:

- [AXI4-Lite Core Interfaces](#)
- [AXI4-Stream Core Interfaces](#)

3.1 AXI4-Lite Core Interfaces

The AXI4-Stream Folded Symmetrical Decimation FIR Filter Core uses the Control/Status Register (CSR) interface to control, and receive status from, the user design.

3.1.1 Control/Status Register (CSR) Interface

The CSR interface is an AXI4-Lite Slave Interface that can be used to access the control and status registers in the FIR Filter Core. [Table 3-1](#) defines the ports in the CSR interface. See [Chapter 4](#) for a Control/Status Register memory map and bit definitions. See the [AMBA AXI4-Lite Specification](#) for more details on operation of the AXI4-Lite interfaces.

Port	Direction	Width	Description
s_axi_csr_aclk	Input	1	Clock
s_axi_csr_aresetn	Input	1	Reset: Active low. This signal will reset all control registers to their initial states.
s_axi_csr_awaddr	Input	13	Write Address: Address used for write operations. It must be valid when s_axi_csr_awvalid is asserted and must be held until s_axi_csr_awready is asserted by the FIR Filter Core.
s_axi_csr_awprot	Input	3	Protection: The FIR Filter Core ignores these bits.
s_axi_csr_awvalid	Input	1	Write Address Valid: This input must be asserted to indicate that a valid write address is available on s_axi_csr_awaddr . The FIR Filter Core asserts s_axi_csr_awready when it is ready to accept the address. The s_axi_csr_awvalid must remain asserted until the rising clock edge after the assertion of s_axi_csr_awready .
s_axi_csr_awready	Output	1	Write Address Ready: This output is asserted by the FIR Filter Core when it is ready to accept the write address. The address is latched when s_axi_csr_awvalid and s_axi_csr_awready are high on the same cycle.

Table 3-1: Control/Status Register (CSR) Interface Port Descriptions (Continued)			
Port	Direction	Width	Description
s_axi_csr_wdata	Input	32	Write Data: This data will be written to the address specified by s_axi_csr_awaddr when s_axi_csr_wvalid and s_axi_csr_wready are both asserted. The value must be valid when s_axi_csr_wvalid is asserted and held until s_axi_csr_wready is also asserted.
s_axi_csr_wstrb	Input	4	Write Strobes: This signal, when asserted, indicates the number of bytes of valid data on the s_axi_csr_wdata signal. Each of these bits, when asserted, indicate that the corresponding byte of s_axi_csr_wdata contains valid data. Bit 0 corresponds to the least significant byte, and bit 3 to the most significant.
s_axi_csr_wvalid	Input	1	Write Valid: This signal must be asserted to indicate that the write data is valid for a write operation. The value on s_axi_csr_wdata is written into the register at address s_axi_csr_awaddr when s_axi_csr_wready and s_axi_csr_wvalid are high on the same cycle.
s_axi_csr_wready	Output	1	Write Ready: This signal is asserted by the FIR Filter Core when it is ready to accept data. The value on s_axi_csr_wdata is written into the register at address s_axi_csr_awaddr when s_axi_csr_wready and s_axi_csr_wvalid are high on the same cycle, assuming that the address has already or simultaneously been submitted.
s_axi_csr_bresp	Output	2	Write Response: The FIR Filter Core indicates success or failure of a write transaction through this signal, which is valid when s_axi_csr_bvalid is asserted; 00 = Success of normal access 01 = Success of exclusive access 10 = Slave Error 11 = Decode Error Note: For more details about this signal refer to the AMBA AXI Specification .
s_axi_csr_bready	Input	1	Write Response Ready: This signal must be asserted by the user logic when it is ready to accept the Write Response.
s_axi_csr_bvalid	Output	1	Write Response Valid: This signal is asserted by the FIR Filter Core when the write operation is complete and the Write Response is valid. It is held until s_axi_csr_bready is asserted by the user logic.
s_axi_csr_araddr	Input	13	Read Address: Address used for read operations. It must be valid when s_axi_csr_arvalid is asserted and must be held until s_axi_csr_arready is asserted by the FIR Filter Core.
s_axi_csr_arprot	Input	3	Protection: These bits are ignored by the FIR Filter Core

Table 3-1: Control/Status Register (CSR) Interface Port Descriptions (Continued)			
Port	Direction	Width	Description
s_axi_csr_arvalid	Input	1	Read Address Valid: This input must be asserted to indicate that a valid read address is available on the s_axi_csr_araddr . The FIR Filter Core asserts s_axi_csr_arready when it is ready to accept the Read Address. This input must remain asserted until the rising clock edge after the assertion of s_axi_csr_arready .
s_axi_csr_arready	Output	1	Read Address Ready: This output is asserted by the FIR Filter Core when it is ready to accept the read address. The address is latched when s_axi_csr_arvalid and s_axi_csr_arready are high on the same cycle.
s_axi_csr_rdata	Output	32	Read Data: This value is the data read from the address specified by the s_axi_csr_araddr when s_axi_csr_arvalid and s_axi_csr_arready are high on the same cycle.
s_axi_csr_rresp	Output	2	Read Response: The FIR Filter Core indicates success or failure of a read transaction through this signal, which is valid when s_axi_csr_rvalid is asserted; 00 = Success of normal access 01 = Success of exclusive access 10 = Slave Error 11 = Decode Error Note: For more details about this signal refer to the AMBA AXI Specification .
s_axi_csr_rvalid	Output	1	Read Data Valid: This signal is asserted by the FIR Filter Core when the read is complete and the read data is available on s_axi_csr_rdata . It is held until s_axi_csr_rready is asserted by the user logic.
s_axi_csr_rready	Input	1	Read Data Ready: This signal is asserted by the user logic when it is ready to accept the Read Data.
irq	Output	1	Interrupt: This is an active high, edge-type interrupt output.

3.2 AXI4-Stream Core Interfaces

The AXI4-Stream Folded Symmetrical Decimation FIR Filter Core has the following AXI4-Stream Interfaces, used to receive and transfer data streams.

- Combined Sample Data/ Timestamp/ Information Stream (PDTI) Interface: This core implements two of these AXI4-Stream interfaces across the input and output to receive and transfer AXI4-Streams.

3.2.1 Combined Sample Data/ Timestamp/ Information Streams (PDTI) Interface

The Pentek Jade series board products have AXI4-Streams that follow a combined Sample Data/ Timestamp/ Information Stream format. This type of data streams combine sample data with its time aligned timestamp and data information. At the input, the FIR Filter Core implements an AXI4-Stream Slave Interface to receive Sample Data/ Timestamp/Information streams from the user design. These are required to be 16-bit data streams with single-sample-per-clock-cycle. The decimated output streams of the FIR filter are transferred through the output AXI4-Stream Master Interface.

[Table 3-2](#), below, defines the ports in the AXI4-Stream Slave and Master Sample Data/ Timestamp/ Information Stream Interfaces. See the [AMBA AXI4-Stream Specification](#) for more details on the operation of the AXI4-Stream Interface.

Table 3-2: Combined Sample Data/ Timestamp/ Information Stream Interface Port Descriptions			
Port	Direction	Width	Description
AXI4-Stream Slave Interface			
aclk	Input	1	AXI4-Stream Clock
aresetn			Reset: Active Low.
s_axis_pdti_tdata		16	Input Data: This is the input data stream.
s_axis_pdti_tvalid		1	Input Data Valid: Asserted when data is valid on s_axis_pdti_tdata .

Table 3-2: Combined Sample Data/ Timestamp/ Information Stream Interface Port Descriptions (Continued)			
Port	Direction	Width	Description
AXI4-Stream Slave Interface (Continued)			
s_axis_pdti_tuser	Input	128	<p>Sideband Information: This is the user defined sideband information received alongside the data stream.</p> <p>tuser [63:0] - Timestamp[63:0] tuser [71:64] - Gate Positions tuser [79:72] - Sync Positions tuser [87:80] - PPS Positions tuser [91:88] - Samples per clock cycle tuser [92] - I/Q data of the sample 0 = I; 1 = Q</p> <p>tuser [94:93] - Data Format => 0 = 8-bit; 1 = 16-bit; 2 = 24-bit; 3 = 32-bit</p> <p>tuser [95] - Data Type => 0 = Real; 1 = I/Q tuser [103:96] - channel [7:0] tuser [127:104] - Reserved</p> <p>Note: The bits [103:96] define the channel number in the user design from where the data is being received.</p>
AXI4-Stream Master Interface			
m_axis_pdti_tdata	Output	num_chan * out_res	Output Data: This is the output data stream.
m_axis_pdti_tvalid		1	Output Data Valid: Asserted when data is valid on m_axis_pdti_tdata .
m_axis_pdti_tuser		128	<p>Sideband Information: This is the user defined sideband information received alongside the data stream.</p> <p>tuser [63:0] - Timestamp[63:0] tuser [71:64] - Gate Positions tuser [79:72] - Sync Positions tuser [87:80] - PPS Positions tuser [91:88] - Samples per clock cycle tuser [92] - I/Q data of the sample 0 = I; 1 = Q</p> <p>tuser [94:93] - Data Format => 0 = 8-bit; 1 = 16-bit; 2 = 24-bit; 3 = 32-bit</p> <p>tuser [95] - Data Type => 0 = Real; 1 = I/Q tuser [103:96] - channel [7:0] tuser [127:104] - Reserved</p> <p>Note: The bits [103:96] define the channel number in the user design from where the data is being received.</p>

3.3 I/O Signals

The I/O port/signal description of the top level module of the FIR Filter Core is discussed in [Table 3-3](#), below. .

Table 3-3: I/O Signals			
Port/ Signal Name	Type	Direction	Description
sat	std_logic	Output	Saturation Indicator: This output indicates saturation of the output data of the core. Active High.

Chapter 4: Register Space

This chapter provides the memory map and register descriptions for the register space of the AXI4-Stream Folded Symmetrical Decimation FIR Filter Core. The memory map is provided in [Table 4-1](#).

Register Name	Address (Base Address +)	Access	Description
Decimation Register	0x0000	R/W	Controls the decimation rate of the input data stream.
Gain Register	0x0004	R/W	Controls the gain of the FIR filter output.
Control Register	0x0008	R/W	Controls bypass enable and sync enable operations of the core.
Coefficient Load	0x000C	R/W	Control the load of the filter coefficients into the FIR filter.
Status Register	0x0010	R	Indicates the status of the coefficients load into the FIR filter.
Interrupt Enable Register	0x0014	R/W	Interrupt enable bits
Interrupt Status Register	0x0018	R	Interrupt source status bits
Interrupt Flag Register	0x001C	R/Clr	Interrupt flag bits
Coefficient RAM Space	0x1000 - 0x1FFF	R/W	Controls the filters coefficients to be written to the Coefficient Block RAM.

4.1 Decimation Register

This register controls the decimation rate of the input data stream to be implemented by the FIR Filter Core. The Decimation Register is illustrated in [Figure 4-1](#) and described in [Table 4-2](#).

Figure 4-1: Decimation Register

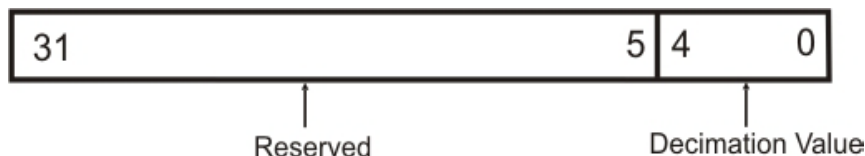

Table 4-2: Decimation Register (Base Address + 0x0000)

Bits	Field Name	Default Value	Access Type	Description
31:5	Reserved	N/A	N/A	Reserved
4:0	dec	00001	R/W	Decimation Value: These bits are used to control the decimation rate of the FIR Filter Core. The actual decimation rate of the core is the value defined by these bits incremented by 1 i.e., (dec +1). It is described as follows: 00001 = decimate by 2 11111 = decimate by 32

4.2 Gain Register

This register controls the gain of the output data from the FIR filter. This register can be accessed through the AXI4-Lite Interface. The Gain Register is illustrated in [Figure 4-2](#) and described in [Table 4-3](#).

Figure 4-2: Gain Register

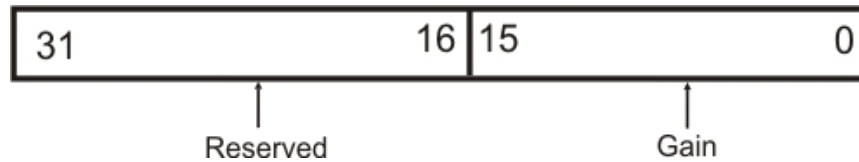

Table 4-3: Gain Register (Base Address + 0x0004)

Bits	Field Name	Default Value	Access Type	Description
31:16	Reserved	N/A	N/A	Reserved
15:0	gain	0x0800	R/W	Gain: These bits control the gain of the FIR filter output. This is a 16-bit unsigned value.

4.3 Control Register

This register controls the sync enable and bypass enable functions of the FIR Filter Core. The sync enable bit of this register enables/ disables the sync signal in the sideband user data of the input AXI4-Stream, to reset the decimation counter of the core. The bypass enable bit of this register is used to enable/ disable the FIR filter in the data flow path of the input data stream. The Control Register is illustrated in [Figure 4-3](#) and described in [Table 4-4](#).

Figure 4-3: Control Register

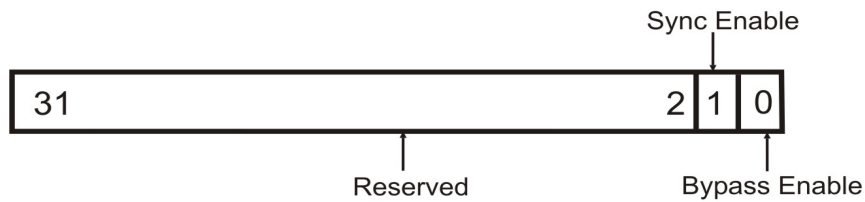

Table 4-4: Control Register (Base Address + 0x0008)

Bits	Field Name	Default Value	Access Type	Description
31:2	Reserved	N/A	N/A	Reserved
1	sync_en	0	R/W	Sync Enable: This bit is used to enable/ disable the sync signal in the input sideband user data stream to reset the decimation counter of the core. 0 = Disable 1 = Enable
0	bypass_n	0	R/W	Bypass Enable: This bit is used to enable/ disable the FIR filter in the input data stream path. 0 = Bypass the Filter 1 = Enable the Filter

4.4 Coefficient Load Register

This register controls the loading of the coefficients into the FIR filter. The coefficient load bit of this register must be toggled '1' then '0' to load the coefficients into the filter. The Coefficient Load Register is illustrated in [Figure 4-4](#) and described in [Table 4-5](#).

Figure 4-4: Coefficient Load Register

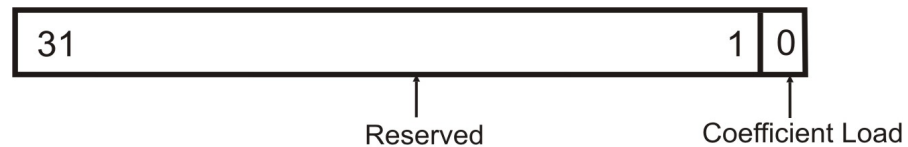

Table 4-5: Coefficient Load Register (Base Address + 0x000C)

Bits	Field Name	Default Value	Access Type	Description
31:1	Reserved	N/A	N/A	Reserved
0	ld_coeff	0	R/W	Coefficient Load: This bit when toggled '1' then '0', enables loading of coefficients into the FIR filter.

4.5 Status Register

This register indicates the status of the coefficient load into the FIR filter. The Status Register is illustrated in [Figure 4-4](#) and described in [Table 4-5](#).

Figure 4-5: Status Register

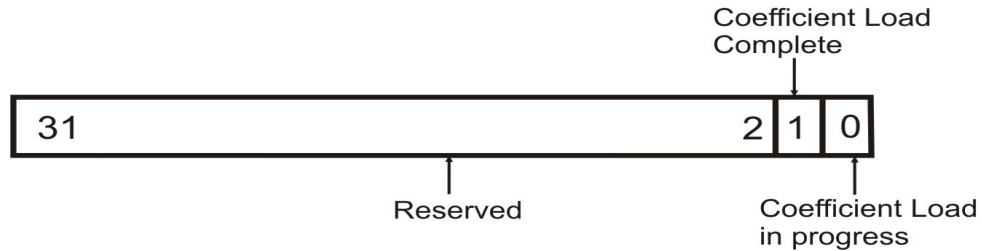

Table 4-6: Status Register (Base Address + 0x0010)

Bits	Field Name	Default Value	Access Type	Description
31:2	Reserved	N/A	N/A	Reserved
1	ld_done	0	R	Coefficient Load Complete: This bit indicates whether all the coefficients have been loaded into the FIR filter. 0 = Coefficient load in progress 1 = Coefficient load complete
0	ld_active	0	R	Coefficient Load in Progress: This bit indicates whether the coefficients are being loaded into the FIR filter. 0 = Coefficient load complete 1 = Coefficient load in progress

4.6 Interrupt Enable Register

The bits in the Interrupt Enable Register are used to enable (or disable) the generation of interrupts based on the condition of certain circuit elements, known as interrupt sources. When a bit in this register associated with a given interrupt source is High, an interrupt will be generated by the rising edge of that source’s Interrupt Status Register bit (See Section 4.7). This register is illustrated in Figure 4-6 and described in Table 4-7.

Figure 4-6: Interrupt Enable Register

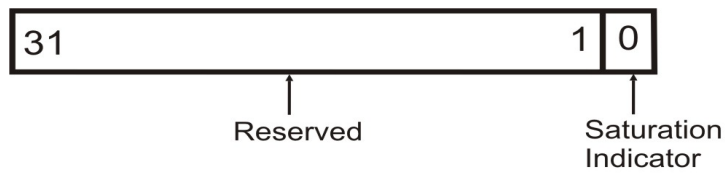

Table 4-7: Interrupt Enable Register (Base Address + 0x0014)				
Bits	Field Name	Default Value	Access Type	Description
31:1	Reserved	N/A	N/A	Reserved
0	sat_int	0	R/W	Saturation Indicator: This bit enables/ disables the saturation interrupt source. The saturation interrupt source indicates the saturation of output data of the core when the FIR filter is not bypassed i.e., bypass enable bit of the Control Register is not '0', 0 = Disable interrupt 1 = Enable interrupt

4.7 Interrupt Status Register

The Interrupt Status Register has read-only access associated with each interrupt condition. A status bit changes to ‘1’ when the source interrupt occurs. When a status bit in this register changes to ‘1’ the corresponding flag bit in the Interrupt Flag Register is set to ‘1’. A status bit in this register clears to ‘0’ when that interrupt condition clears, whereas the associated flag bit in the Interrupt Flag Register remains at logic ‘1’ until it is explicitly cleared by the user.

Some of the interrupt sources are transient and so may not appear in the Interrupt Status Register at the time it is read. In such cases use the Interrupt Flag Register to see the interrupt conditions that have occurred. The Interrupt Status Register is illustrated in [Figure 4-7](#) and described in [Table 4-8](#).

Figure 4-7: Interrupt Status Register

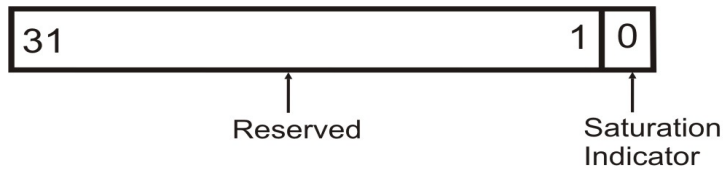

Table 4-8: Interrupt Status Register (Base Address + 0x0018)

Bits	Field Name	Default Value	Access Type	Description
31:1	Reserved	N/A	N/A	Reserved
0	sat_int	0	R	Saturation Indicator: This bit indicates the status of the saturation interrupt source. The saturation interrupt source indicates the saturation of output data of the core when the FIR filter is not bypassed i.e., bypass enable bit of the Control Register is not ‘0’, 0 = No interrupt 1 = Interrupt condition asserted

4.8 Interrupt Flag Register

The Interrupt Flag Register has a read/clear access associated with each interrupt condition. When reset, this register has all bits set to '0' (cleared). Each flag bit in this register latches an interrupt occurrence. A '1' in any flag bit in this register indicates that an interrupt has occurred.

Note that when any status bit in the Interrupt Status Register, changes to '1' the corresponding flag bit in this register will also be set to '1'. However, when a status bit in the Interrupt Status Register clears from '1' to '0', the corresponding latched flag bit in this register does not clear, but remains at '1'. To clear the flag bits, write '1's to the desired bits. The flags are not affected by the enable register. The Interrupt Flag Register is illustrated in Figure 4-8 and described in Table 4-9.

Figure 4-8: Interrupt Flag Register

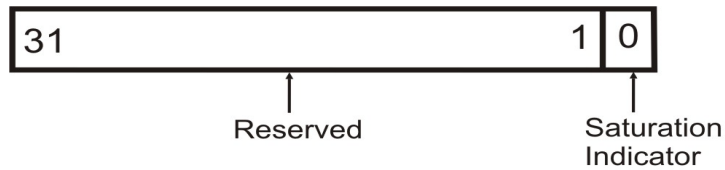

Bits	Field Name	Default Value	Access Type	Description
31:1	Reserved	N/A	N/A	Reserved
0	sat_int	0	R/Clr	<p>Saturation Indicator: This bit indicates the saturation interrupt flag. The saturation interrupt source indicates the saturation of output data of the core when the FIR filter is not bypassed i.e., bypass enable bit of the Control Register is not '0',</p> <p>Read: 0 = No interrupt 1 = Interrupt latched</p> <p>Clear: 1 = Clear latch</p>

4.9 Coefficient RAM Space

When the address range of 0x1000 to 0x1FFF is accessed through the AXI4-Lite Interface, it indicates access to the Coefficient Block RAM of the core. Coefficients can be written to or read from the Block RAM through the AXI4-Lite Interface by accessing this address range. The Coefficient Block RAM is accessed through the Pentek Block RAM Controller IP Core.

- The filter coefficients of this core are 18-bits wide.
- The filter can have upto 28 times the decimation number of coefficients.
- The filter coefficients must be symmetrical with even number of taps.
- Although the entire coefficient set may be loaded into the Coefficient RAM, only the first half of the coefficient set is used by the FIR filter.
- If using less than the maximum number of coefficients, pad first and last unused coefficients with zeroes, centering the used coefficients.

Chapter 5: Designing with the Core

This chapter includes guidelines and additional information to facilitate designing with the AXI4-Stream Folded Symmetrical Decimation FIR Filter Core.

5.1 General Design Guidelines

The FIR Filter Core provides the required logic perform decimation and filtering of the input data stream. This core can be controlled through the control registers within the core as described in [Chapter 4](#), which determine the operation of the core. The output resolution and type of input data streams can be defined through the generic parameters as described in [Section 2.5](#)

5.2 Clocking

AXI4-Stream Clock: **aclk**

This clock is used to clock all ports in the FIR Filter Core.

CSR Clock: **s_axi_csr_aclk**

This clock is used to clock the AXI4-Lite Interface, Register Space, and the Coefficient Block RAM of the core.

5.3 Resets

Main reset: **aresetn**

This is an active low reset synchronous with the AXI4-Stream clock (**aclk**).

CSR Reset: **s_axi_csr_aresetn**

This is an active low reset synchronous with the CSR clock (**s_axi_csr_clk**).

5.4 Interrupts

This core has an edge-type (rising edge-triggered) interrupt output. It is synchronous with the **s_axi_csr_aclk**. On the rising edge of any interrupt signal, a one clock cycle wide pulse is output from the core on its **irq** output. Each interrupt event is stored in two registers, accessible on the **s_axi_csr** bus.

5.4 Interrupts (continued)

The Interrupt Status Register always reflects the current state of the interrupt condition, which may have changed since the generation of the interrupt. The Interrupt Flag Register latches the occurrence of each interrupt, in a bit that retains its state until explicitly cleared. The Interrupt flags can be cleared by writing ‘1’ to the associated bit’s location. All interrupt sources that are enabled (via the Interrupt Enable Register) are “OR ed” onto the **irq** output.

NOTE: All interrupt sources are latched in the interrupt flag register, even when an interrupt source is not enabled to create an interrupt.

NOTE: Because this core uses edge-triggered interrupts, the fact that an interrupt condition may remain active after servicing will not cause the generation of a new interrupt. A new interrupt will only be generated by another rising edge on an interrupt source.

5.5 Interface Operation

CSR Interface: This is the Control/Status Register Interface and is associated with **s_axi_csr_aclk**. It is a standard AXI4-Lite Slave interface. See [Chapter 4](#) for the control/ status register memory map, which provides more details on the registers that can be accessed through this interface.

Combined Sample Data/ Timestamp/ Information Streams (PDTI) Interfaces: This core implements two AXI4-Stream interfaces at the input and output to receive/ transfer data streams, and are associated with **aclk**. For more details about these interfaces please refer to [Section 3.2](#).

5.6 Programming Sequence

This section briefly describes the programming sequence of registers in the FIR Filter Core.

- 1) Assign desired values to the generic parameters.
- 2) Set the control register with the required values based on the desired mode of operation of the core.
- 3) Write the filter coefficients into the Coefficient Block RAM.
- 4) Toggle the coefficient load bit of the Coefficient Load Register to load the coefficients into the FIR filter.
- 5) Observe the output data stream across the output ports when valid data is available at the input ports.

5.7 Timing Diagrams

The timing diagrams for the FIR Filter Core are obtained by running the simulation of the test bench of the core in Vivado VSim environment. For more details about the test bench, refer to [Section 6.5](#).

This page is intentionally blank

Chapter 6: Design Flow Steps

6.1 Pentek IP Catalog

This chapter describes customization and generation of the Pentek AXI4-Stream Folded Symmetrical Decimation FIR Filter Core. It also includes simulation, synthesis, and implementation steps that are specific to this IP core. This core can be generated from the Vivado IP Catalog when the Pentek IP Repository has been installed. It will appear in the IP Catalog list as `px_axis_fdecfir32_1_v1_0` as shown in [Figure 6-1](#).

Figure 6-1: AXI4-Stream Folded Symmetrical Decimation FIR Filter Core in Pentek IP Catalog

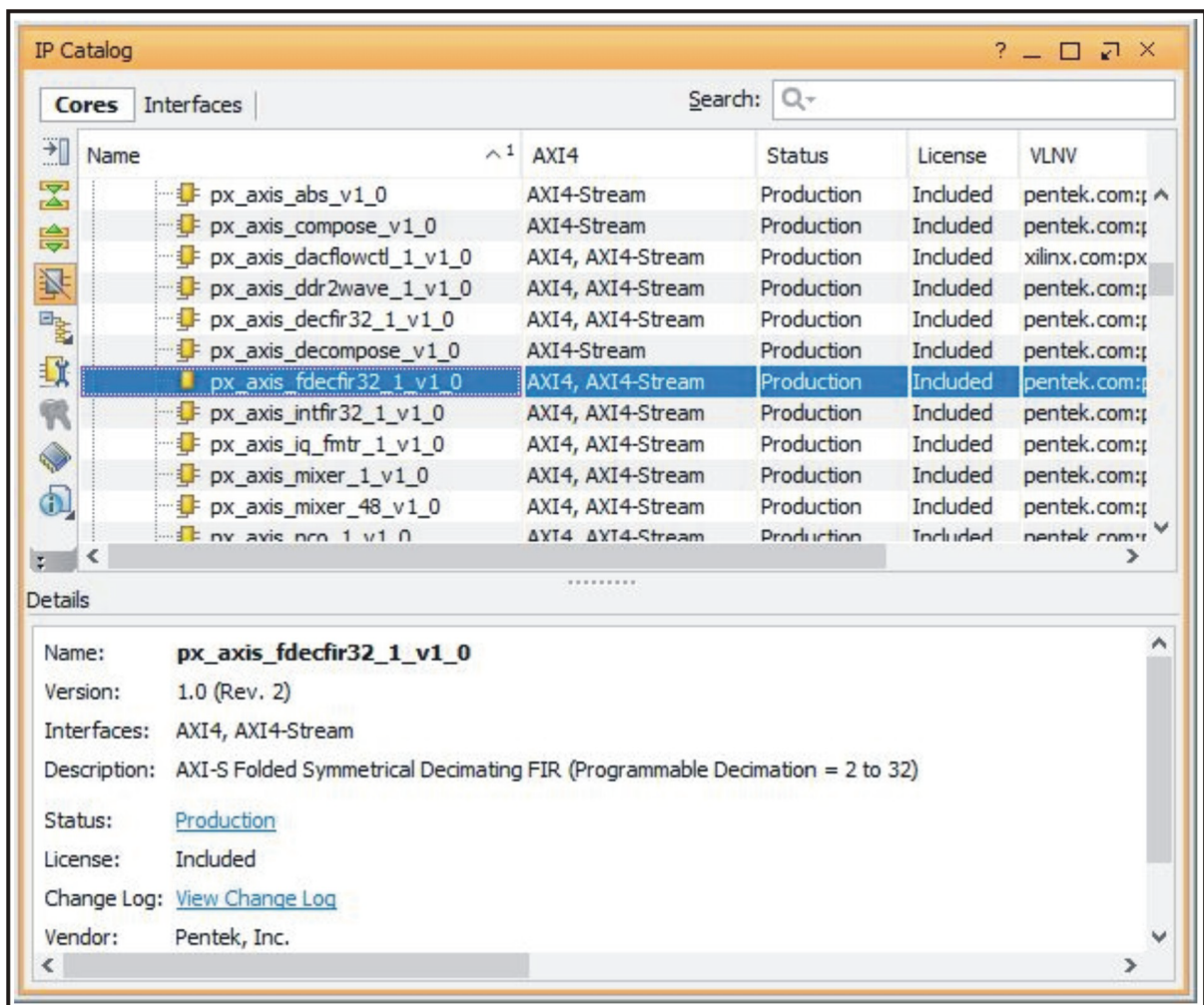

6.1 Pentek IP Catalog (continued)

When you select the `px_axis_fdecfir32_1_v1_0` core, a screen appears that shows the core's symbol and the core's parameters (see [Figure 6-2](#)). The core's symbol is the box on the left side.

Figure 6-2: AXI4-Stream Folded Symmetrical Decimation FIR Filter Core IP Symbol

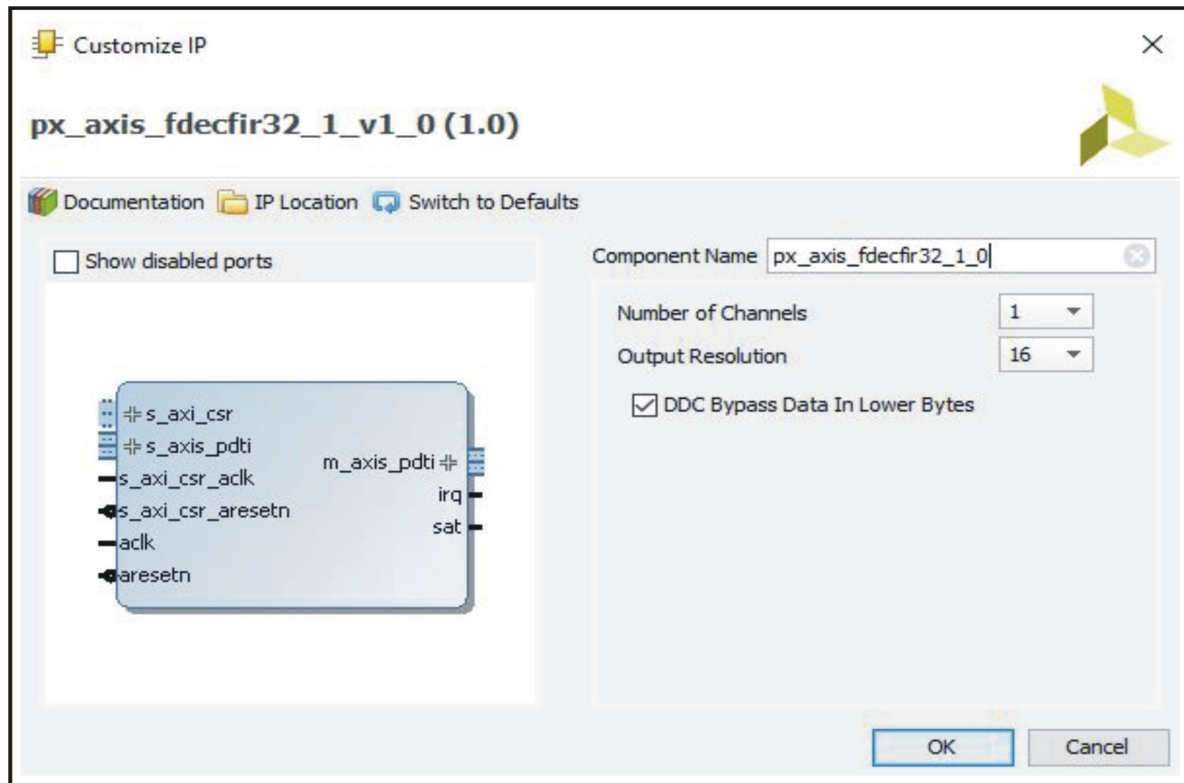

6.2 User Parameters

The user parameter for this core are described in the [Section 2.5](#) of this user manual.

6.3 Generating Output

For more details about generating and using IP in the Vivado Design Suite, refer to the [Vivado Design Suite User Guide - Designing with IP](#).

6.4 Constraining the Core

This section contains information about constraining the AXI4-Stream Folded Symmetrical Decimation FIR Filter Core in Vivado Design Suite.

Required Constraints

The XDC constraints are not provided with the FIR Filter Core. Clock constraints can be applied in the top-level module of the user design.

Device, Package, and Speed Grade Selections

This IP works for the Kintex Ultrascale FPGAs.

Clock Frequencies

The CSR clock (`s_axi_csr_aclk`) and the AXI4-Stream clock (`aclk`) have the same maximum operating frequency of 250 MHz.

Clock Management

This section is not applicable for this IP core.

Clock Placement

This section is not applicable for this IP core.

Banking and Placement

This section is not applicable for this IP core.

Transceiver Placement

This section is not applicable for this IP core.

I/O Standard and Placement

This section is not applicable for this IP core.

6.5 Simulation

The AXI4-Stream Decimation FIR Filter Core has a test bench which generates output waveforms using the Vivado VSim environment. The test bench is designed to run at 250 MHz CSR clock frequency and 200 MHz AXI4-Stream clock frequency. The output resolution of the core is set to 16-bits with incoming data streams in the complex IQ data format. The testbench has filter coefficients defined for decimation rate of 2 and 4. The input data stream to the FIR Filter Core is generated using a Xilinx Direct Digital Synthesizer Core whose input phase increment is derived from the input data frequency of 1 MHz defined in the testbench.

6.5 Simulation (continued)

The testbench has a decimation rate of 4 with a gain of 800, with sync signal disabled, and bypass disabled. The filter coefficients corresponding to the specified decimation rate are loaded into the Coefficients Block RAM. When the coefficients are loaded into the Coefficients RAM, the Coefficient Load Register bit is toggled to enable loading of the coefficients into the filter. When run, the simulation produces the results shown in Figure 6-3.

Figure 6-3: AXI4-Stream Folded Symmetrical Decimation FIR Filter Core Test Bench

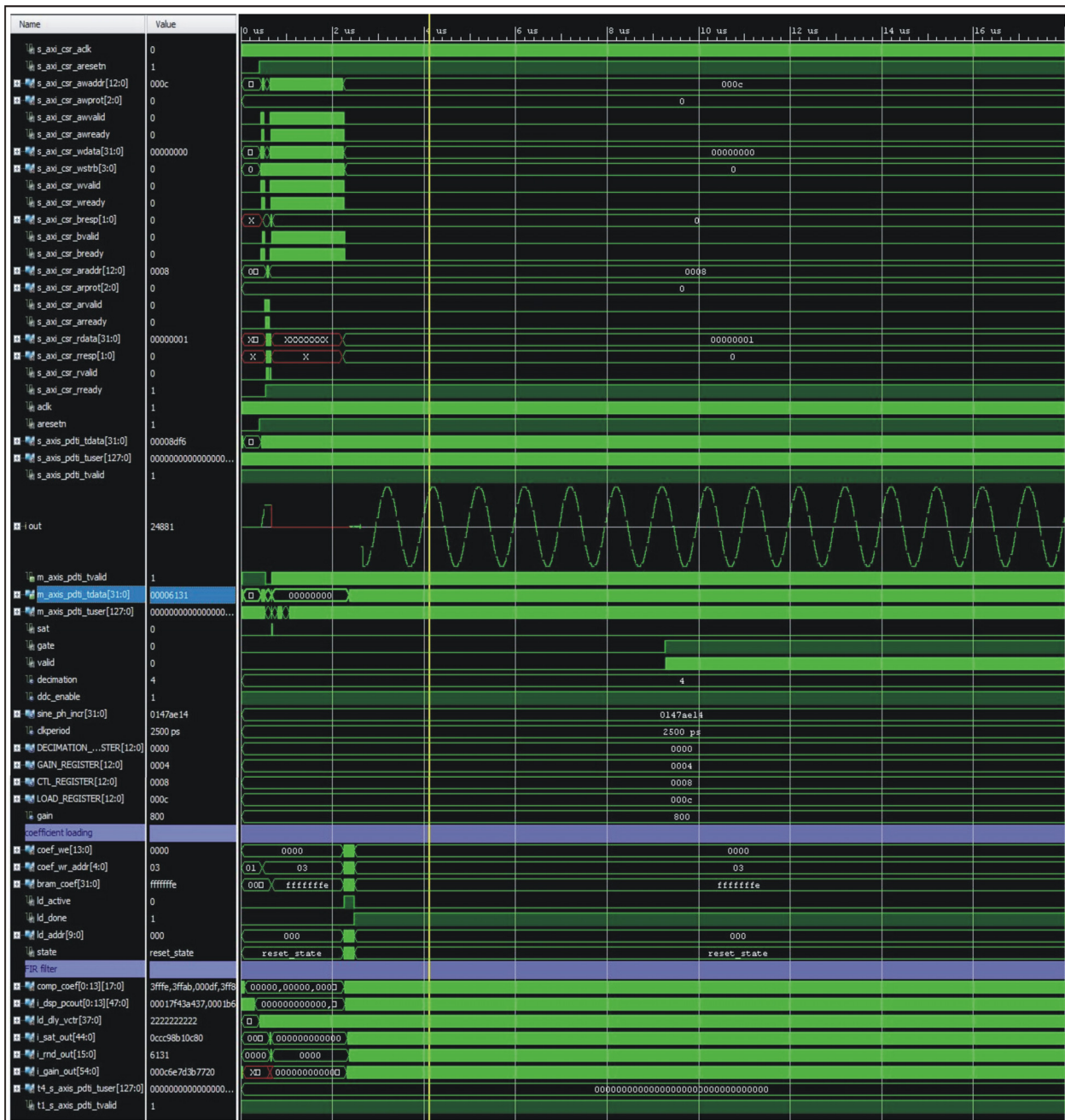

6.6 Synthesis and Implementation

For details about synthesis and implementation see the [*Vivado Design Suite User Guide - Designing with IP*](#).

This page is intentionally blank