

PowerCommand iWatch™

Remote Network Monitoring

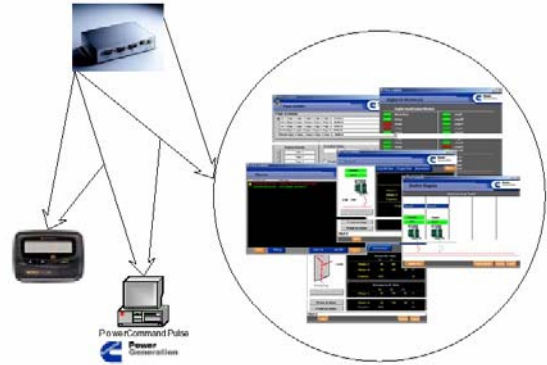

Description

The PowerCommand iWatch system provides convenient means for remotely monitoring generator sets and transfer switches that are interconnected with a Cummins Echelon LonWorks™ network using an Internet Explorer™ browser operating on a remote personal computer (PC).

The use of a browser rather than dedicated software for remote monitoring eliminates the need for dedicated monitoring software on the monitoring PC, and allows any authorized user on the customer's network to monitor the equipment. Many users can monitor the generator or transfer equipment simultaneously. Access to the monitored site(s) requires set up of the user on the system by an administrator, and use of a password for each user.

iWatch users can monitor generator set data, including engine data, alternator data, and control system status. They can start or stop the generator set (when the user access level authorizes that action.) The user can also monitor connected transfer switches for status (source availability and source connected) as well as load level (when the transfer switch is provided with that feature).

Cummins Echelon LonWorks networks can monitor any generator set or transfer switch from any manufacturer, so facilities with equipment from multiple companies can be monitored with a single operating system.

Features

- **Easy Access to Generator Set and Transfer Switch Data.** Allows access to information over any personal computer without the problems associated with loading software and keeping it up to date.
- **Easy to Use and Understand Graphical Interface.** Data is presented to user in a pictorial format that is easy to understand. The graphical displays provide comprehensive data without complexity.
- **Allows Equipment to Page for Service on Alarms.** The control system monitors generator sets and transfer switches for alarm conditions, and pages designated technicians based on a configurable priority and schedule.
- **Sends Emails on Alarm Conditions.** Allows generator set and transfer switches to send email messages on alarm conditions using an SMTP server.
- **Configurable for User Access Codes.** Provides a means to limit access to the generator sets and transfer switches in 3 levels: administrator, user, and observer.
- **Integrated DC Power Supply.** Equipment includes a DC UPS to support system operation during time periods when AC power is not available.
- **Local Data Logging.** The iWatch system can be used for data-logging on network. Data stored may be accessed via either local or remote PC's.
- **Certifications.** UL listed.
- **Warranty and Service.** Backed by a 1-year warranty and worldwide distributor service network.

System Description

The iWatch system is composed of several major groups of equipment and software. The generator sets, transfer switches, and other equipment monitored at a site are interconnected with a Cummins PowerCommand LonWorks network. The network is connected to the iWatch hardware module, which is connected to a TCP/IP Ethernet connection.

Optionally, the iWatch hardware module may also be connected to a telephone service line, so that the control may dial out on alarms and send messages to a pager service; or the control may be accessed through the modem for browsing.

The system monitoring limitations at an individual site are:

- Up to 30 generator sets, or;
- Up to 15 generator sets with 15 transfer switches and 6 digital I/O modules (DIM)

PowerCommand LonWorks Network

PowerCommand generator sets and transfer switches can be provided with network interface modules to allow direct monitoring and control by an Echelon LonWorks network. The network can also monitor digital I/O modules that accept discrete signals from auxiliary equipment, and provide discrete commands from the network (and also iWatch) to local devices. Generator set and transfer equipment from any supplier can be monitored with dedicated PowerCommand interface modules.

Typical Information Displays

Main Menu

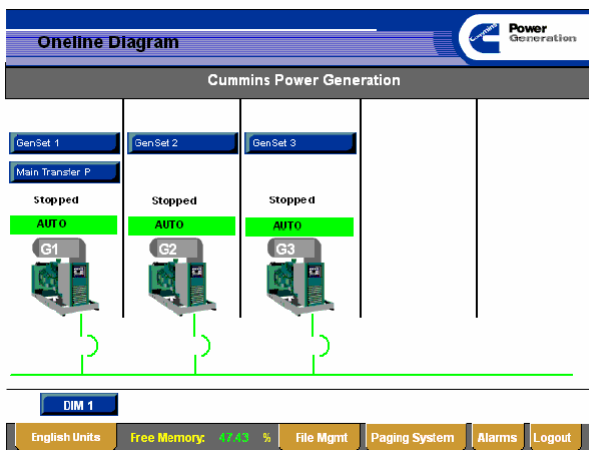

The main menu screen displays the equipment monitored by the iWatch location that is connected. It also displays the basic status of each component, such as whether it is operating or what sources are available. The user may click on a component that is displayed or one of the tabs at the bottom of the screen to navigate to other system displays. When a warning or shutdown condition is present on any equipment monitored, a warning (yellow) or shutdown (red) banner is displayed on the screen.

Generator Set AC Data Display

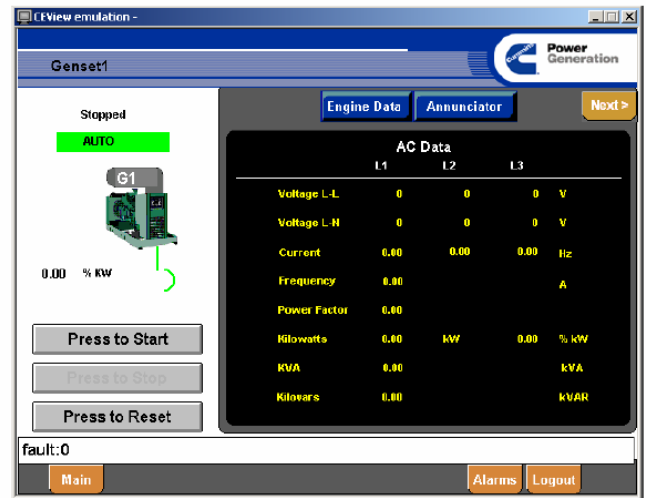

The generator set AC data display screen provides information on the current AC voltage, current, frequency, power factor, kW, kVA, and kVAR output of the generator set monitored. The screen also allows manual starting and stopping of the generator set for operators that are authorized to perform that function. For paralleling applications other screens may be provided that show generator set state, breaker positions, and other information.

Generator Set Engine Data Display

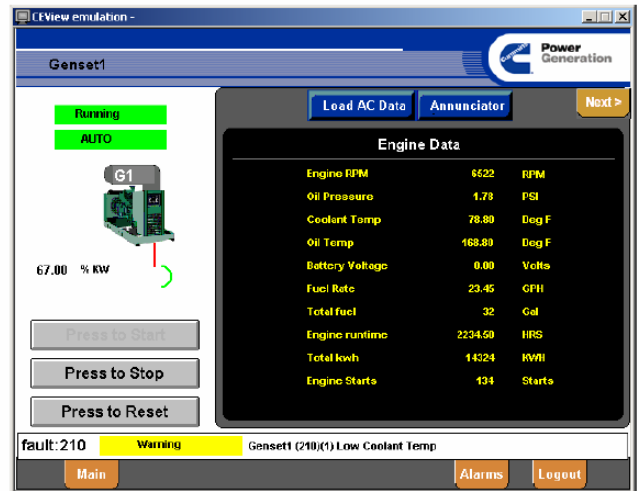

The generator set engine data display provides detailed information on the state of the engine, including speed, oil pressure, coolant temperature, oil temperature, battery voltage, fuel rate and total fuel consumed (when available), engine running hours, kW hours, and number of starts. Units of measurement are configurable for either US Standard or Metric values. The screen also allows manual starting and stopping of the generator set for operators that are authorized to perform that function.

Remote Annunciator Display

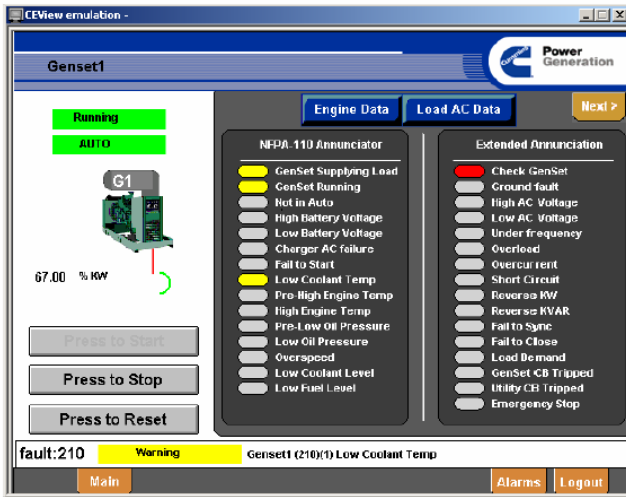

This display emulates operation of a genset annunciators, providing status condition on one screen for the major components in the system. The screen also allows manual starting and stopping of the generator set for operators that are authorized to perform that function.

Transfer Switch Data Display

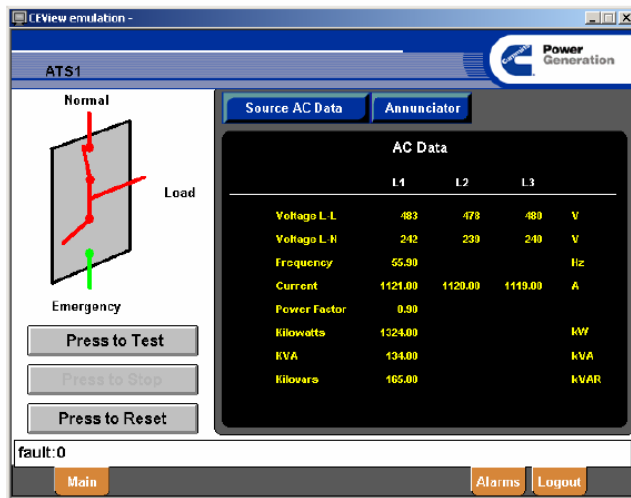

This screen graphically shows the status of the transfer switch by depiction of available sources as red, and unavailable sources as green, with the normal source and generator source switches shown as either open or closed. The display also provides tabular data covering the individual phase voltage and frequency for each source; and when available, the individual phase load current, power factor, kW, kVA, and kW hours. The screen also allows manual testing of the transfer switch for operators that are authorized to perform that function.

Digital I/O Module Display

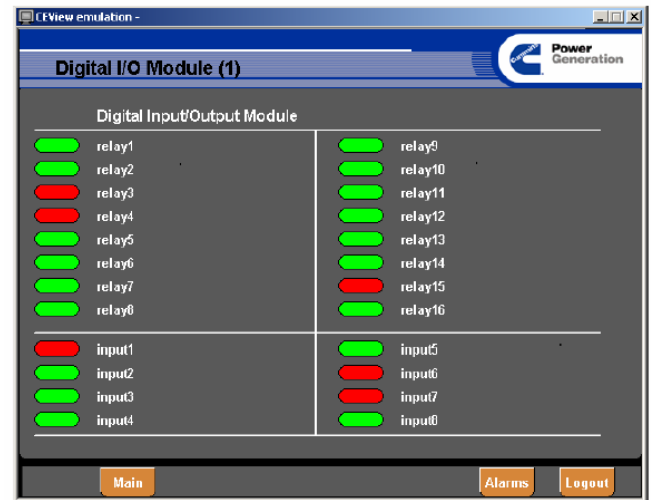

Digital I/O modules on the PowerCommand LonWorks network allow the network to monitor discrete inputs from fuel systems and other equipment, so that a user may see their status (green-normal, yellow-warning, or red-shutdown) and control them from a remote location.

Fault History Display

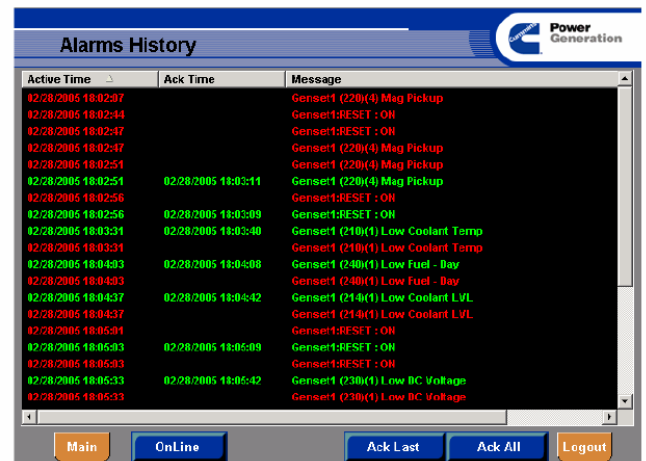

The fault information display provides the user with a date and time-stamped remote indication of alarm conditions that have occurred at a site. The data displayed is the name of the device on the network and the name of the alarm condition that occurred. Conditions that have been acknowledged are shown in green text, and those that have not are shown in red.

Monitoring Equipment Requirements

The PC monitoring the iWatch system must be provided with Microsoft Internet Explorer version 6.0 or later. Any equipment suitable for use with that application is acceptable.

Environment

The iWatch hardware equipment is mounted in a NEMA 1 enclosure. The equipment is designed for operation in ambient temperatures from 0C to +50C.

Dimensional Data

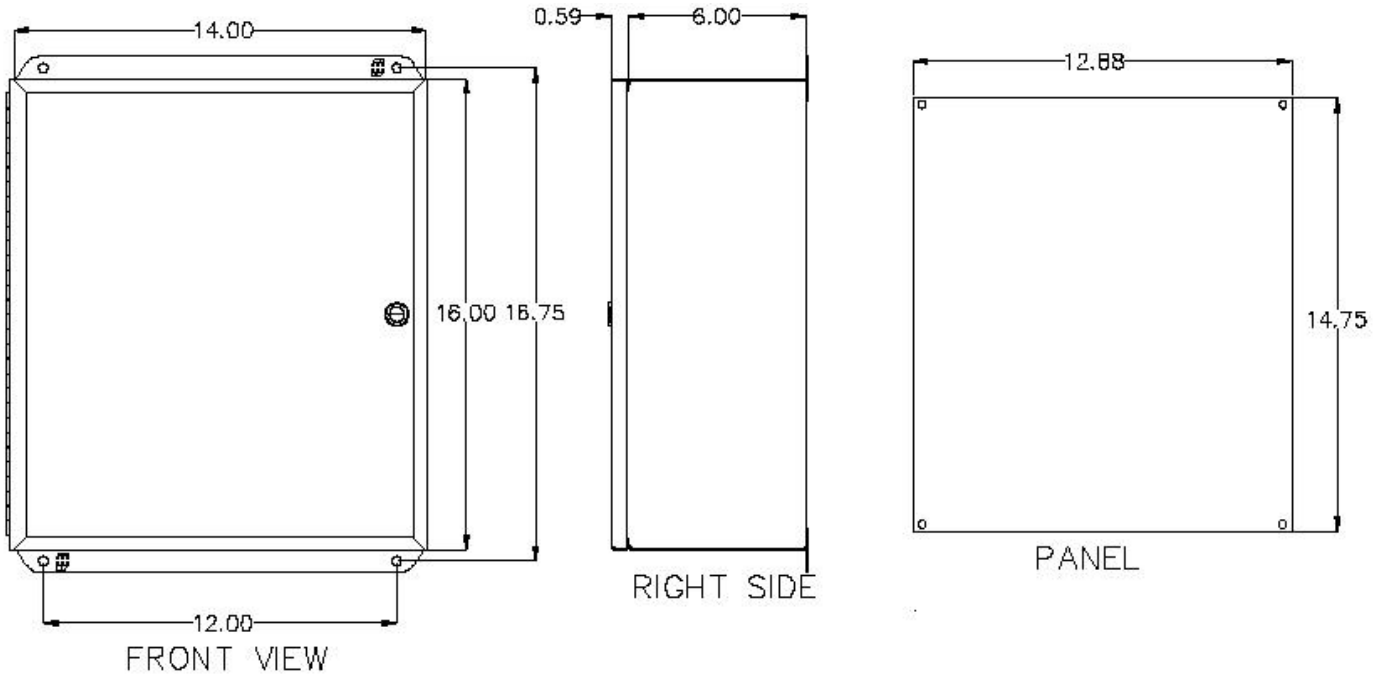

See your distributor for more information



Cummins Power Generation
1400 73rd Avenue N.E.
Minneapolis, MN 55432
763.574.5000
Fax: 763.574.5298
www.cumminspowergeneration.com

Cummins and PowerCommand are registered trademarks of Cummins Inc.
InPower and AmpSentry are trademarks of Cummins Inc. Internet Explorer is a trademarked product of Microsoft, Inc. LonWorks is a trademark of Echelon Corporation.

Important: Backfeed to a utility system can cause electrocution and/or property damage. Do not connect generator sets to any building electrical system except through an approved device or after building main switch is open.