

FT-10 Network Digital I/O Module Kits 541-0771 and 541-0772

PURPOSE OF KIT

The Digital I/O Module (DIM) makes provisions for a group of relay contact outputs and discrete inputs to interface with a PowerCommand® FT-10 network. The DIM enables alarms or status output signals to equipment that does not have compatible communications capability.

Base Digital I/O Module

The base Digital I/O Module is shown in Figure 1.

The following items are included in the base Digital I/O Module kit (541-0771):

Part Description	Qty
Base Digital I/O Module	1
Plug Connector – J9 (2 Pin, Grey)	1
Plug Connector – J3 (6 Pin, Black)	1
Plug Connector – J6 (8 Pin, Black)	1
Plug Connector – J1, J7, and J8 (8 Pin, Grey)	3

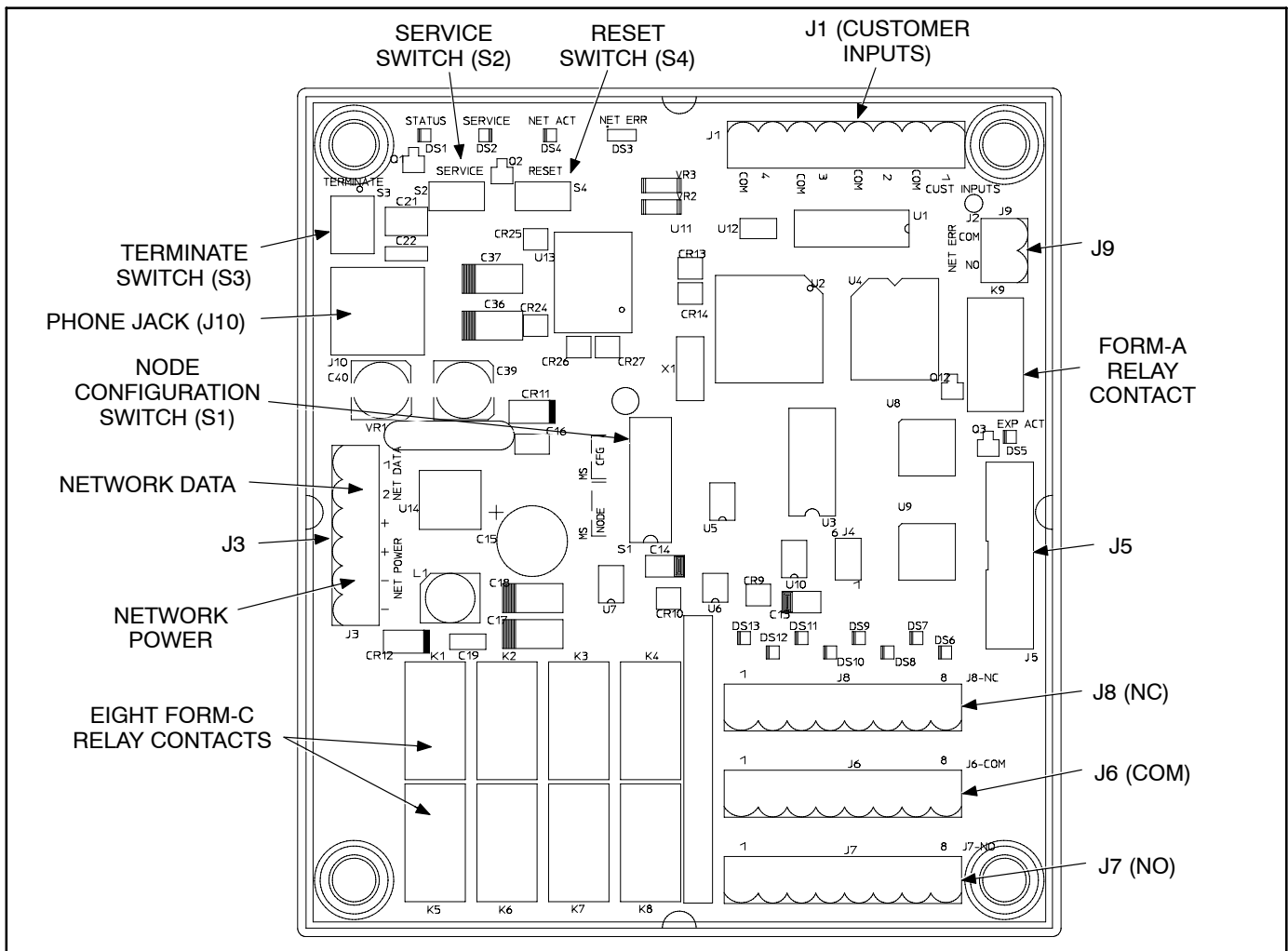

FIGURE 1. BASE DIGITAL I/O MODULE

PowerCommand is a registered trademark of Cummins Inc.
LONWORKS is a registered trademark of Echelon Corporation.
LonMaker is a trademark of Echelon Corporation.

Digital I/O Expansion Module

The Digital I/O Expansion Module is shown in Figure 2. If an expansion module is used, it must be installed with a base DIM. The following items are included in the Digital I/O Expansion Module kit (541-0772):

Part Description	Qty
Digital I/O Expansion Module	1
Plug Connector – J2 (8 Pin, Black)	1
Plug Connector – J1, J3, and J4 (8 Pin, Grey or Green)	3

GENERAL INFORMATION

Each module provides eight Form-C relay contacts, which are driven by data from the network. The con-

tacts are connected to terminal blocks for field wiring. Each relay can be programmed to operate from any variable on the network. Each module also includes four isolated discrete inputs to couple user inputs to the network for additional control and monitoring. If both kits are installed, there is a total of sixteen relays and eight user inputs.

All network data wiring must follow a specific network topology and must fall within distance limits. Network power wiring must be sized according to source voltage, distance and load.

Refer to the *PowerCommand Network Installation and Operation Manual (900-0529)* for instructions on wiring, installing, and connecting this module to the network.

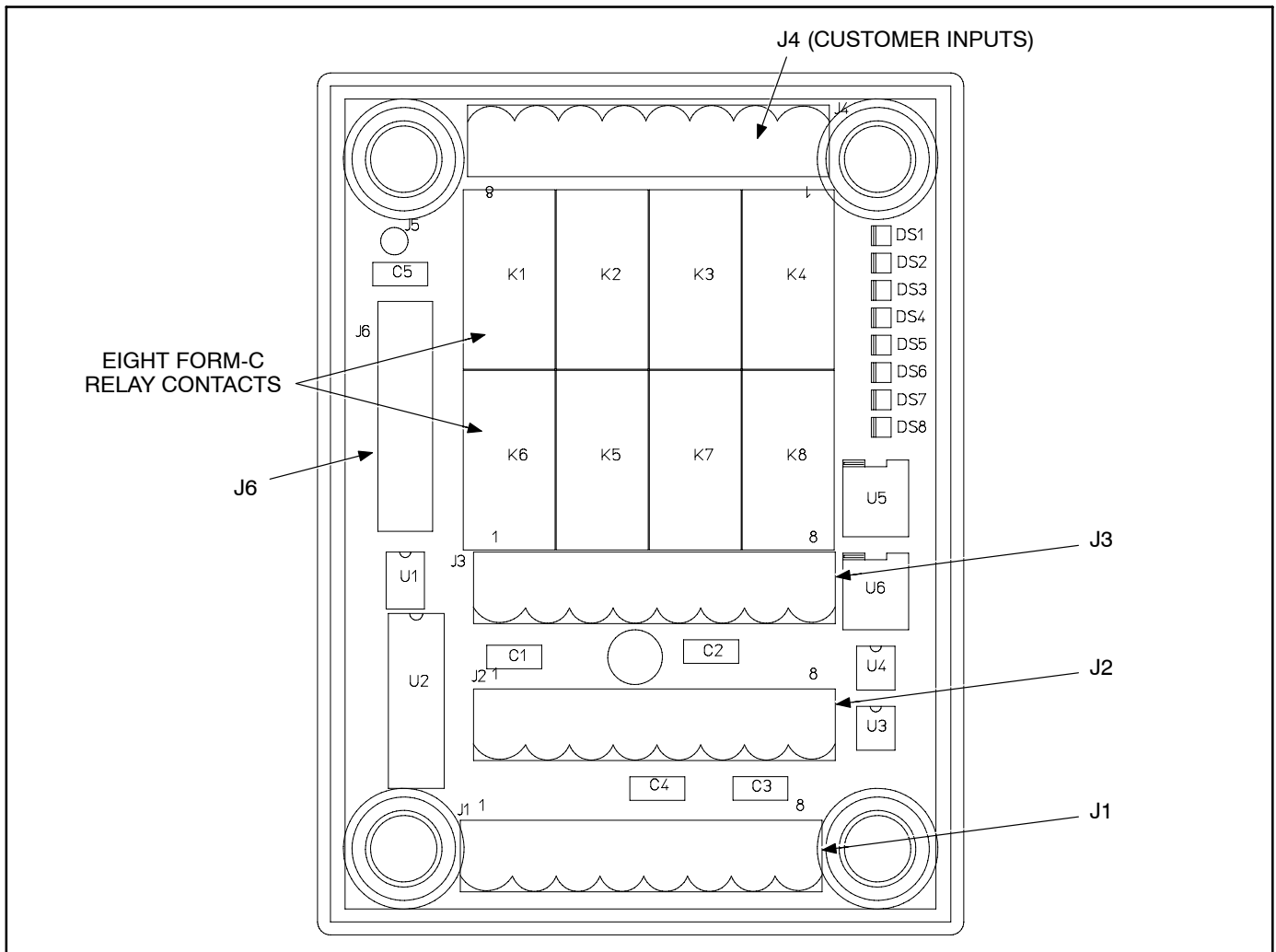

FIGURE 2. DIGITAL I/O EXPANSION MODULE

PHYSICAL INSTALLATION

Location

The modules are packaged for panel mounting within other equipment enclosures.

If there is a site network installation drawing, refer to it for the module location. If a site network installation drawing is not available, refer to the *Power-Command Network Installation and Operation Manual (900-0529)* for network topology, maximum network length and power supply requirements.

Choose a clean, vibration-free mounting surface. Avoid locations that are hot, damp, or dusty or that are close to EMI sources. The temperature range must not exceed -40°F (-40°C) to 85°F (29°C).

Mounting

Figure 3 shows the Digital I/O Module base and expansion outline dimensions. The outside dimen-

sions do not include necessary clearance for wire connections.

If mounting the module to a wall, make sure that no wires, plumbing, gas or exhaust lines run behind the wall before drilling the mounting holes. Ground the J2 and J5 ring terminals to Earth ground (see Figure 4).

Termination

If the DIM is to be terminated, the termination switch S3 on the base module must be set (see Figure 1). This is accomplished by moving it to the ON position.

NOTE: For free topology, only one device on each segment must be terminated. Multidrop bus topology requires termination at each end of the bus using multidrop bus terminators (Echelon P/N 44101) or the device terminator switch.

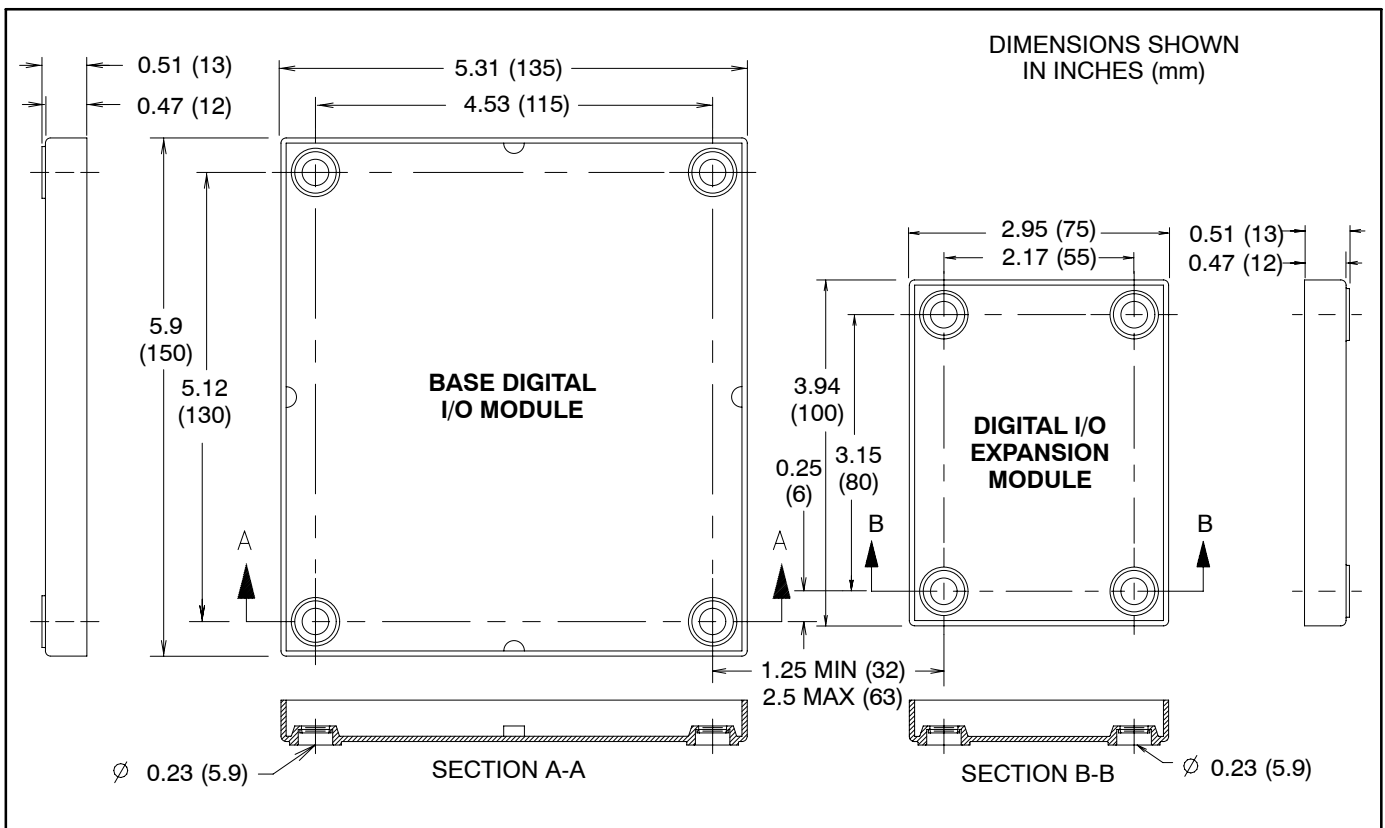

FIGURE 3. DIGITAL I/O MODULE FOOTPRINTS

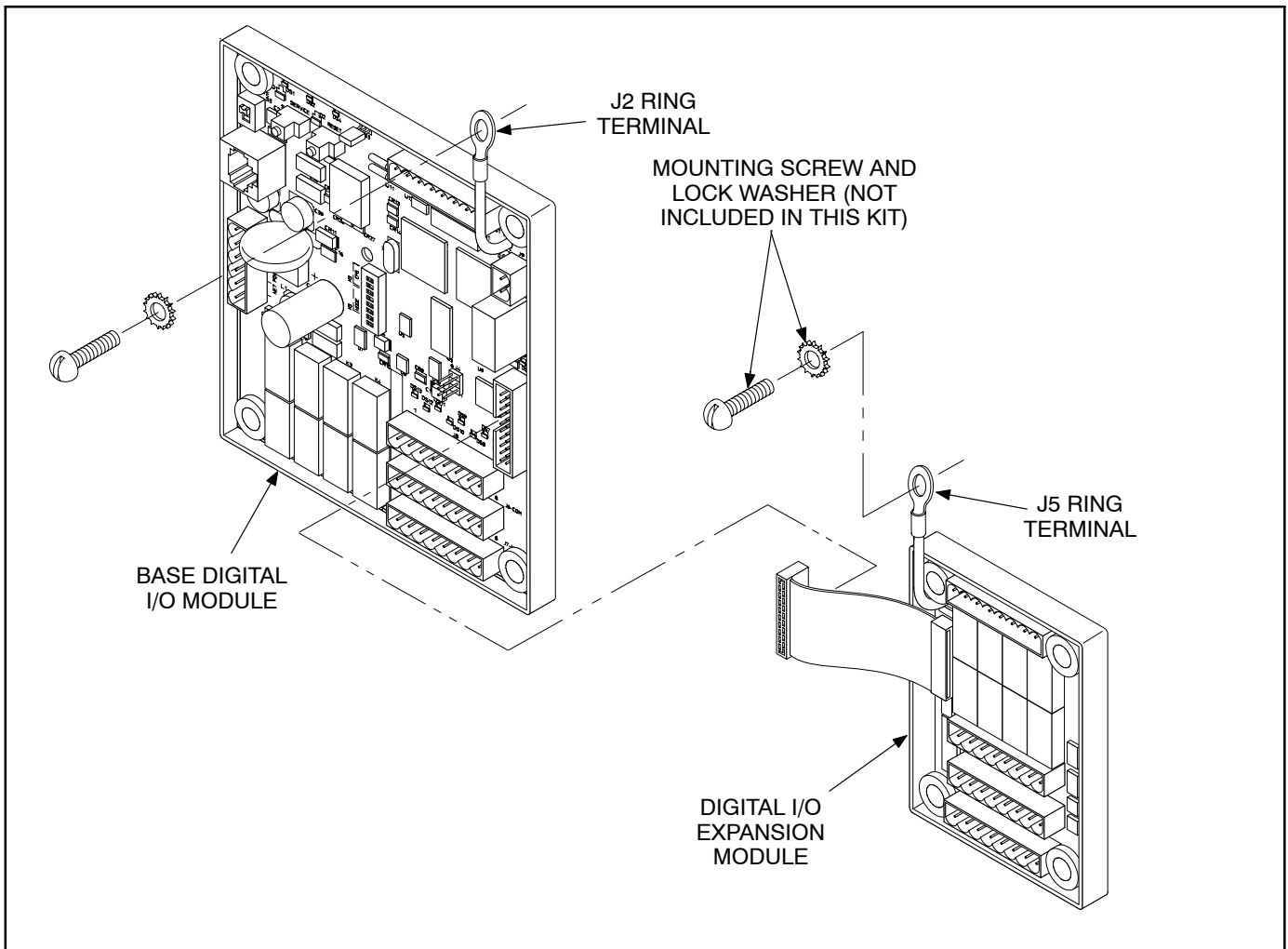

FIGURE 4. DIGITAL I/O MODULE INSTALLATION

WIRING DIAGRAM

Figure 5 shows the interconnect wiring diagram for the Digital I/O Modules. Refer to the specifications and notes for the drawing (see Figure 6).

Inputs

The base and expansion modules each have four discrete inputs which can be connected to external dry contacts. These inputs must be referenced back to their “input common” terminals (J1 on the base DIM and J4 on the DIM expansion module) through dry contacts (refer to note 6 on Figure 6).

Outputs

The Digital I/O base and expansion modules each provide eight 0.5A, 125VAC/30VDC Form-C dry contact latching relay outputs. Secure wires in the terminal block to 2 inch-lbs. (0.23 N•m).

Power Supply

The Digital I/O operates between 10–36 VDC. Refer to the *PowerCommand Network Installation and Operation Manual (900–0529)* for power supply information.

NOTE: Refer to Figure 6 for Specifications and Notes.

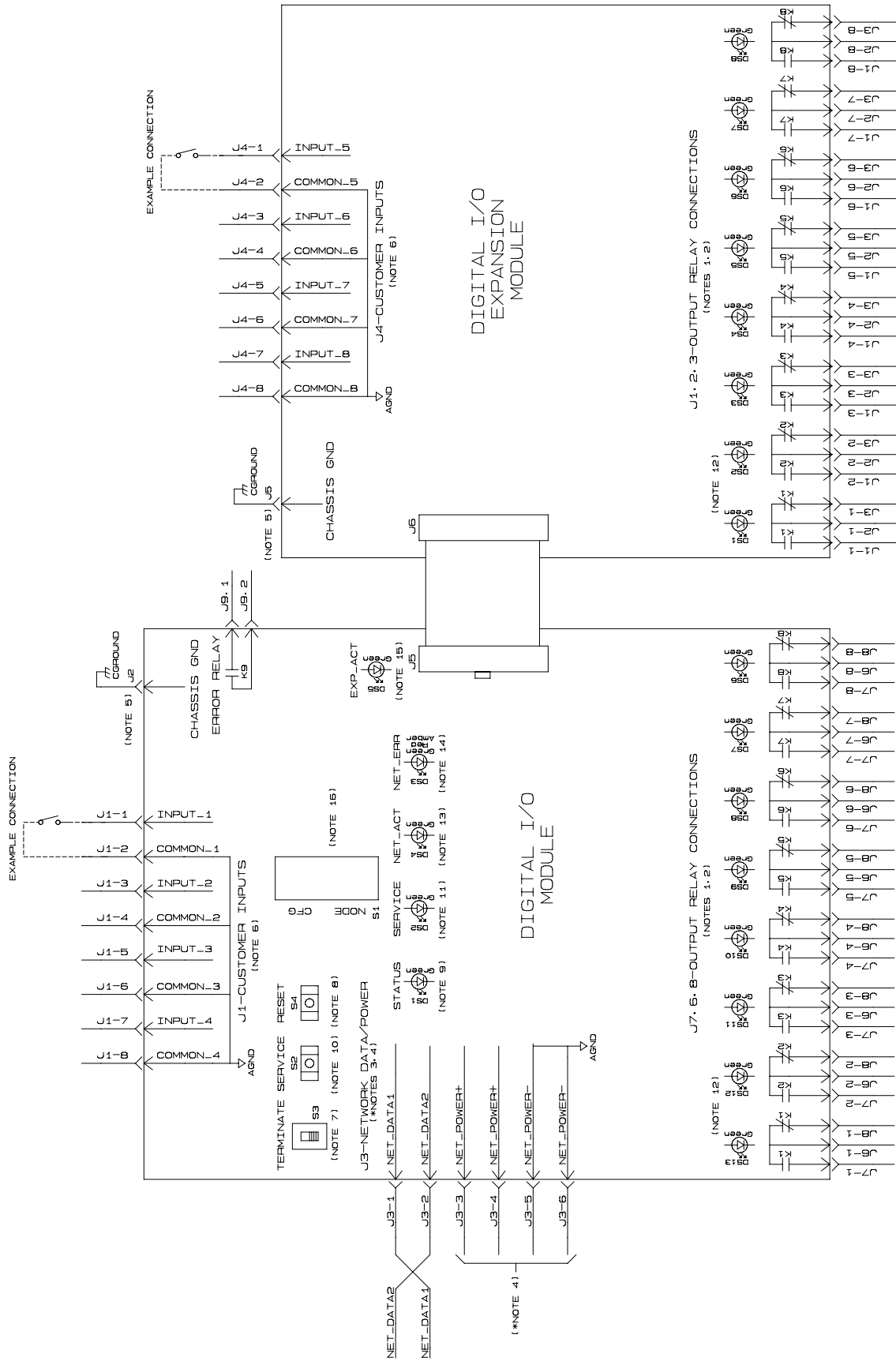

FIGURE 5. DIGITAL I/O MODULE INTERCONNECT WIRING DIAGRAM

SPECIFICATIONS

1. NET POWER
 - 1.1 INPUT VOLTAGE = 8-40VDC
(OPERATING RANGE)
 - 1.2 INPUT CONNECTIONS = J3-3(NET POWER+)
J3-5(NET POWER-)
 - 1.3 OUTPUT CONNECTIONS = J3-4(NET POWER+)
J3-6(NET POWER-)
2. NET DATA
 - 2.1 TYPE ECHELON LONTALK™
78KD TWISTED PAIR
TRANSFORMER COUPLED
 - 2.2 INPUT CONNECTIONS = J3-1(NET DATA1)
J3-2(NET DATA2)
3. CUSTOMER INPUTS
 - 3.1 TYPE = DISCRETE
 - 3.2 NUMBER = 4 : 8 WITH EXPANSION BOARD
CONNECT TO DRY CONTACTS ONLY
RETURN TO COMMON OF SAME NUMBERED INPUT
 - 3.3 OUTPUT = 5VDC (OPEN)
5mA SOURCE MAX (CLOSED)
 - 3.8 INPUT CONNECTIONS =

J1-1(INPUT 1)	1262	board
J1-2(COMMON 1)	1262	board
J1-3(INPUT 2)	1262	board
J1-4(COMMON 2)	1262	board
J1-5(INPUT 3)	1262	board
J1-6(COMMON 3)	1262	board
J1-7(INPUT 4)	1262	board
J1-8(COMMON 4)	1262	board
J4-1-8	on 1265	board
4. OUTPUT RELAYS
 - 4.1 TYPE = NON-LATCHING
 - 4.2 NUMBER = 8 : 16 WITH EXPANSION BOARD
 - 4.3 CONTACTS = 1 FORM C

.5A, 250VAC	1262	board
1A, 125VAC	1265	board
2A, 30VDC		

(RATINGS LIMITED BY UL TEST)
 - 4.4 OUTPUT CONNECTIONS =

J8(N/C CONTACTS)	1262	board
J6(COMMON)	1262	board
J7(N/O CONTACTS)	1262	board
J3(N/C CONTACTS)	1265	board
J2(COMMON)	1265	board
J1(N/O CONTACTS)	1265	board
5. ENVIRONMENTAL
 - 5.1 STORAGE TEMPERATURE = -40 TO 85 °C
 - 5.2 OPERATING TEMPERATURE = -40 TO 85 °C
 - 5.3 HUMIDITY = 45 TO 85% RH

6. NETWORK ERROR RELAY
 - 6.1 TYPE = NON-LATCHING
 - 6.2 NUMBER = 1
 - 6.3 CONTACTS = 1 FROM A (NORMALLY OPEN)
1 AMP, 250V AC, 30V DC
 - 6.4 OUTPUT CONNECTIONS = J9 - 1 (NORMALLY OPEN)
J9 - 2 (COMMON)

NOTES

1. ALL RELAYS SHOWN IN RESET OR DE-ENERGIZED POSITION. DO NOT MAINTAIN THE LAST STATE WHEN POWER IS LOST.
2. OUTPUT RELAYS ARE CONTROLLED VIA THE NETWORK.
3. REFER TO INTERCONNECTION PRINT (0630-2293).
4. REFER TO POWERCOMMAND NETWORK INSTALLATION AND OPERATION MANUAL (900-0529).
5. CONNECT J2 RING TERMINAL TO A GOOD EARTH GROUND. USE AN 'EXTERNAL TOOTH' LOCKWASHER BETWEEN RING AND GROUNDING SURFACE.
6. DO NOT APPLY VOLTAGE TO CUSTOMER INPUTS 1-8 (J1 AND J4)
7. S3, WHEN SET TO TERMINATE, WILL TERMINATE THE TWISTED PAIR BUS. DATA LINES MUST BE TERMINATED WHEN THE DIM IS PHYSICALLY LOCATED AT THE END OF THE NETWORK BUS.
8. S4, RESET PUSH-BUTTON SWITCH, WILL MANUALLY RESET THE DIM.
9. DS1, STATUS LED(GREEN), INDICATES DIM PROCESSOR IS RUNNING.
10. S2, SERVICE PUSH-BUTTON SWITCH, USED TO GENERATE NETWORK MANAGEMENT MESSAGE FOR NODE LOGICAL INSTALLATION.
11. DS2, SERVICE LED(AMBER), INDICATES THE INSTALLATION AND ERROR STATUS.
12. DS6-DS13(GREEN) ON THE DIM BOARD INDICATE WHICH RELAYS ARE ENERGIZED.
DS1-DS8(GREEN) ON THE EXPANSION BOARD INDICATE WHICH RELAYS ARE ENERGIZED.
13. DS4, NET_ACT LED(GREEN), INDICATES NETWORK ACTIVITY.
14. DS3, NET_ERR LED(GREEN, RED, AMBER), INDICATES NETWORK CONNECTION. IF IT IS RED, THE DIM IS NOT CONNECTED TO THE NETWORK. IF IT IS AMBER, IT IS CONNECTED, BUT NOT BOUND.
IF IT IS GREEN, THE DIM IS CONNECTED AND BOUND.
15. DS5, EXP_ACT LED(GREEN), INDICATES COMMUNICATION BETWEEN MAIN AND EXPANSION BOARD.
16. S1, CONFIGURATION SWITCH, USED TO CONFIGURE DEVICE FOR SELF-INSTALLATION. REFER TO POWERCOMMAND NETWORK INSTALLATION AND OPERATION MANUAL, 900-0529.

REF. 630-2276C

FIGURE 6. DIGITAL I/O MODULE INTERCONNECT WIRING DIAGRAM

SELF-INSTALLATION

Configuration

When using the self-installation method, the DIM is configured with switch S1 only. Switch S1 sets the *Node Address* and *Autobinding* configuration.

Node Address

Each node on a self-installed network must have a unique address. Switches 1 through 4 of S1 are used to set the *Node Address* of the DIM. The default binary node address is 1000 (decimal address = 8), which is a "STATUS" LED pulse rate of 8.

The switches are oriented so that switch S1-1 is the most significant bit (MSB) of the *Node Address*. Thus, S1-1 has a value of "8" when it is ON. S1-2 has a value of 4, S1-3 has a value of 2, and S1-4 has a value of 1.

Example: To set up a *Node Address* of 3, set switch node configuration switch S1 as follows: S1-1 OFF, S1-2 OFF, S1-3 ON and S1-4 ON (binary setting

0011=0+0+2+1=3 decimal). See Table 1 and Figure 7.

TABLE 1. SETTING THE NODE ADDRESS (S1-1-4)

S1-1 (8)	S1-2 (4)	S1-3 (2)	S1-4 (1)	Address (binary)	Address (decimal)
OFF	OFF	OFF	OFF	0000	0 ¹
OFF	OFF	OFF	ON	0001	1
OFF	OFF	ON	OFF	0010	2
OFF	OFF	ON	ON	0011	3
				↓	↓
ON	ON	ON	ON	1111	15

Note 1: "0" (zero) is not a valid Address.

Be sure to assign each node in the network a unique address. The *Node Address* can be verified by counting the number of pulses of the "STATUS" LED (DS1). See Figure 7.

NOTE: If the DIM is installed using LonMaker, switches S1-1 thru S1-4 have no bearing on the *Node Address*.

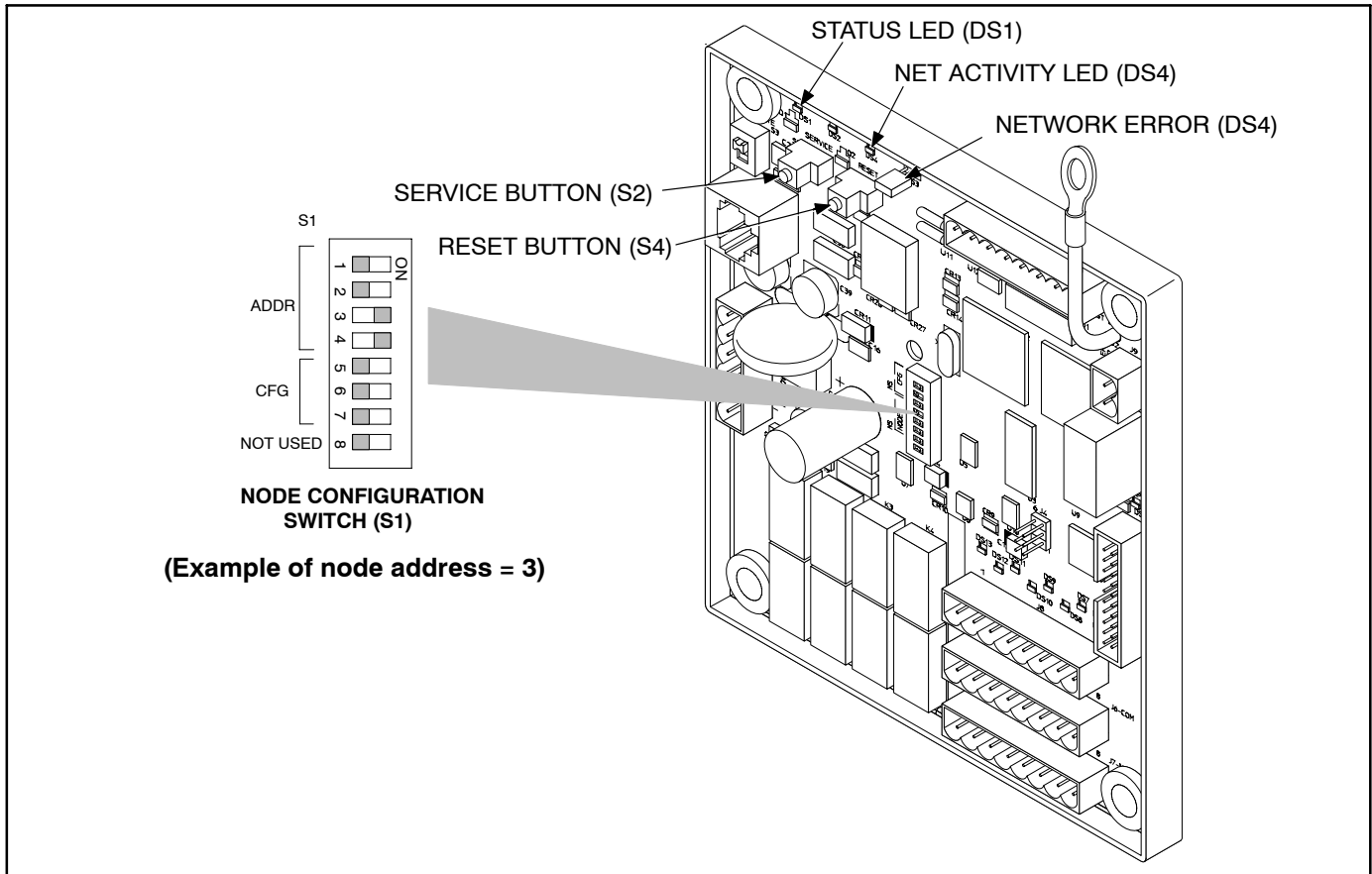

FIGURE 7. DIM SWITCHES

Autobinding Configurations

For self-installation, the DIM may be configured for 1 of 5 configurations: *NFPA 110*, *Genset Extended*, *Genset Custom*, *ATS Extended*, or *Relay Custom* (PCC 2100 only). Up to 5 DIMs may be self-installed without requiring LonMaker™. However, each DIM must be configured for a different configuration (*NFPA 110*, *Genset Extended*, *Genset Custom*, *ATS Extended*, or *Relay Custom*). See Table 2 to configure switches S1-5, S1-6, and S1-7.

NOTE: Relays cannot be individually configured when self-installed.

TABLE 2. SWITCH CONFIGURATION SETTINGS

S1-5	S1-6	S1-7	CONFIGURATION	CONFIG. VALUE
OFF	OFF	OFF	NFPA 110	0
OFF	OFF	ON	Genset Extended	1
OFF	ON	OFF	Genset Custom	2
OFF	ON	ON	ATS Extended	3
ON	OFF	OFF	Relay Custom	4
ON	OFF	ON	N/A	5
ON	ON	OFF	N/A	6
ON	ON	ON	N/A	7

Table 3 shows the autobinding configurations for gensets and transfer switches. For installations that include a PCC 2100, additional autobinding configurations for gensets are available (see Table 4).

When changing the desired configuration, re-bind the Genset and/or ATS to the network. See *Binding*.

PCC 2100 Custom Relay Autobinding Configurations

In addition to the other four configurations, a DIM may autobind to a genset with a PCC 2100 control so that the status of the eight inputs are bound to the PCC 2100 network variables, while the 16 user-defined faults on the PCC 2100 are bound to the DIM relays.

Refer to the *PowerCommand Network Installation and Operation Manual* (900-0529).

NOTE: This feature is available only when autobinding to a genset with a PCC 2100 control.

Logical Installation

After configuring S1 as desired and the DIM is *physically* connected to the Genset and/or ATS, the DIM is ready to be *logically* connected to a Genset and/or ATS. Logically connecting to another device is referred to as *binding*. Binding may be done at any time after all nodes are installed, connected, and powered.

1. Make sure the DIM, Genset and/or ATS LON-WORKS® modules are all powered and all are connected to the twisted-pair data bus.
2. Make sure S1-1, S1-2, S1-3, and S1-4 on the base DIM are configured for the desired address. Each device on the network must have a unique address.
3. Make sure S1-5, S1-6, and S1-7 on the base DIM are configured for the desired configuration.
4. Make sure the network is terminated.
5. Press and hold the *Service* button (S2) (see Figure 7) until the *Network Status* LED (DS1) begins flashing (amber).
6. Release the *Service* button.

At this time, the DIM will self-install and bind to the Genset and/or ATS. If it is able to bind to either a Genset or ATS, the *Network Status* lamp turns green. If no Genset or ATS devices are detected, the lamp remains amber. If lamp remains amber, verify data connections to Genset and/or ATS.

NOTE: The Genset and ATS must be CPG FT-10 devices that are able to self-install in the network. Each device on the network must have a unique address.

Binding Sequence

Logically connecting to another device is referred to as *binding*. *Binding* may be done when all the nodes are installed, connected, and powered.

Binding the node must occur in the proper sequence. Logically install the genset first, followed by the transfer switch, and then the annunciator(s) and other network accessories.

NOTE: The genset module and ATS module must be Cummins Power Generation (CPG) devices

which are able to self-install in the network. Each device on the network must have a unique address.

Verify Binding

To verify the genset has installed itself properly and is bound to the ATS, disconnect the J3 data cable from the engine interface board. The “Network Error” LED (DS3) (see Figure 7) should turn on (red) within 10 seconds. This indicates communications have failed and that the device was properly bound.

Reconnect the twisted pair cable and confirm that DS3 turns off within ten seconds.

Remove Bindings

If unresolved system errors occur, the bindings can be removed and then re-installed to reset the system. The bindings can also be removed if the network is being changed or the device is being moved to another network.

To remove all bindings from the device, change the *Node Address* (S1) to 0 (zero) and logically re-install the device.

The node will remove all bindings at this time, including the genset and annunciator bindings. The “STATUS” LED will not flash when the *Node Address* is 0, nor will it attempt to bind to a genset.

Re-Binding

Re-Binding the node must occur in the proper sequence. Logically install the genset first, followed by the transfer switch, and then the annunciator(s), DIMs, and other network accessories.

To re-bind an annunciator, DIM, or ATS to the genset node, press and hold the Service pin for two seconds.

LONMAKER INSTALLATION

The DIM can be installed with LonMaker. The CPG Service Stencil is required. To install with LonMaker:

1. Run **LonMaker**. Refer to the *PowerCommand Network Installation and Operation Manual* (900-0529).
2. Open the Device Stencil.
3. Create a new site (or update an existing site).
4. Define, install, and bind devices.
5. Verify system operation.

The DIM is defined and installed like any other device in LonMaker.

TABLE 3. AUTOBINDING CONFIGURATIONS AVAILABLE FOR THE GENSET AND ATS

DIM RELAY	GENSET NFPA 110	GENSET EXTENDED	GENSET OR RELAY CUSTOM	ATS NFPA 110	ATS EXTENDED
Relay 1	Common Alarm	Check Genset	User-defined Fault 1	Common Alarm	Source1 Available
Relay 2	Genset Supplying Load	Ground Fault	User-defined Fault 2	Genset Supplying Load	Source2 Available
Relay 3	Genset Running	High AC Voltage	User-defined Fault 3	ATS Not In Auto	Source1 Connected
Relay 4	Genset Not In Auto	Low AC Voltage	User-defined Fault 4		Source2 Connected
Relay 5	High Battery	Under Frequency	User-defined Fault 5		Check ATS
Relay 6	Low Battery	Overload	User-defined Fault 6		ATS Not in Auto
Relay 7	Charger AC Failure	Overcurrent	User-defined Fault 7	Charger AC Failure	Test/Exercise
Relay 8	Fail to Start	Short Circuit	User-defined Fault 8		Low ATS Battery
Relay 9	Low Engine Temp	Reverse kW	User-defined Fault 9		Load Shed
Relay 10	Pre-High Engine Temp	Reverse kVAR	User-defined Fault 10		Transfer Inhibit
Relay 11	High Engine Temp	Fail to Sync	User-defined Fault 11		Retransfer to Inhibit
Relay 12	Pre-Low Oil Pressure	Fail to Close	User-defined Fault 12		Fail to Close
Relay 13	Low Oil Pressure	Load Demand	User-defined Fault 13		Fail to Disconnect
Relay 14	Overspeed	Genset CB Tripped	User-defined Fault 14		Fail to Sync
Relay 15	Low Coolant Level	Utility CB Tripped	User-defined Fault 15		Bypass to Source1
Relay 16	Low Fuel Level	Emergency Stop	User-defined Fault 16		Bypass to Source2

TABLE 4. RELAY CUSTOM AUTOBINDING CONFIGURATIONS AVAILABLE FOR THE GENSET (PCC 2100 ONLY)

DIM RELAY	GENSET OR RELAY CUSTOM
Input 1	Network Fault 1
Input 2	Network Fault 2
Input 3	Network Fault 3
Input 4	Network Fault 4
Input 5	Network Fault 5
Input 6	Network Fault 6
Input 7	Network Fault 7
Input 8	Network Fault 8