

General Description

The P400W2-6CP SSPA is a high power, broadband, solid state power amplifier housed in an EIA compatible 3U height rack mountable chassis. The amplifier incorporates a wide input range AC-DC power supply, fan-forced convective thermal management, and an internal driver amplifier. The amplifier is appropriate for high-power wide-band testing, communications, radar, or any application requiring capability for simultaneous power amplification of signals across the 2.0-6.0 GHz spectrum.

The P400W2-6CP incorporates high efficiency GaN MMICs, spatially combined in a compact structure to achieve robust, high performance power amplification across the 2.0-6.0 GHz frequency range.



Product Features

- 2.0-6.0 GHz
- 400 Watts saturated output power
- 62 dB small signal gain
- 54 dB nominal power gain
- 208-250 VAC 47-63 Hz AC input
- Side intake/rear exhaust convection cooling
- Enclosure options: Hub or rack mount
- Built in PPG or external trigger

Performance is typical across frequency. Please reference electrical specification table and data plots for more details.

Applications

- Radar
- Communications
- Test & Measurement
- EMI Testing

Ordering Information

Part No.	ECCN	Description
P400W2-6CP	TBD	2.0-6.0 GHz 400 Watt Amplifier

Functional Block Diagram

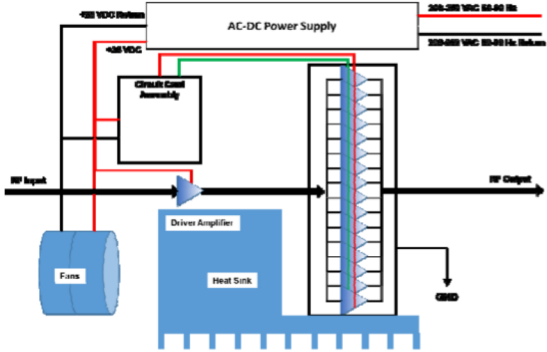

Absolute Maximum Ratings

Parameter	Rating
RF Input Power, CW, 50 Ω, T _{CASE} =25 °C	+10 dBm
Load VSWR	3.0:1
AC Current (120, 220, 250 VAC)	14A, 7.7A, 6.8 A
Storage Air Temperature	-40 to +85 °C
Operating Air Temperature	-40 to +71 °C

Exceeding any one or a combination of the Absolute Maximum Rating conditions may cause permanent damage to the device. Extended application of Absolute Maximum Rating conditions to the device may reduce device reliability.

Recommended Operating Conditions

Parameter	Min	Typ	Max	Units
Voltage (V _{AC})	90	220	265	V _{RMS}
AC Frequency	47	60	63	Hz
Operating Air Temperature	0	25	50	°C
RF Input Power, CW		0		dBm

Electrical specifications are measured at specified test conditions. Specifications are not guaranteed over all recommended operating conditions.

Electrical Specifications

Parameter	Conditions	Min	Typ	Max	Units
Operational Frequency Range		2		6	GHz
Output Power (P _{IN} = 35 dBm)	2 GHz		55.8		dBm
	4 GHz		57.1		dBm
	6 GHz		55.7		dBm
Power Added Eff. (P _{IN} = 35 dBm)	2 GHz		39.0		%
	4 GHz		37.7		%
	6 GHz		27.3		%
Power Gain (P _{IN} = 35 dBm)	2 GHz		20.8		dB
	4 GHz		22.1		dB
	6 GHz		20.7		dB
Small Signal Gain	2 GHz		32.5		dB
	4 GHz		30.6		dB
	6 GHz		26.6		dB
Input Return Loss	2 GHz		8		dB
	4 GHz		23		dB
	6 GHz		20		dB
Output 2 nd Harmonic (P _{IN} = 35 dBm)			See plot		dBc
Output 3 rd Harmonic (P _{IN} = 35 dBm)			See plot		dBc
Unit Weight	Rack Mount Enclosure		25		kg
Unit Weight	Rack Mount Enclosure		25		kg

Block Diagram and Description

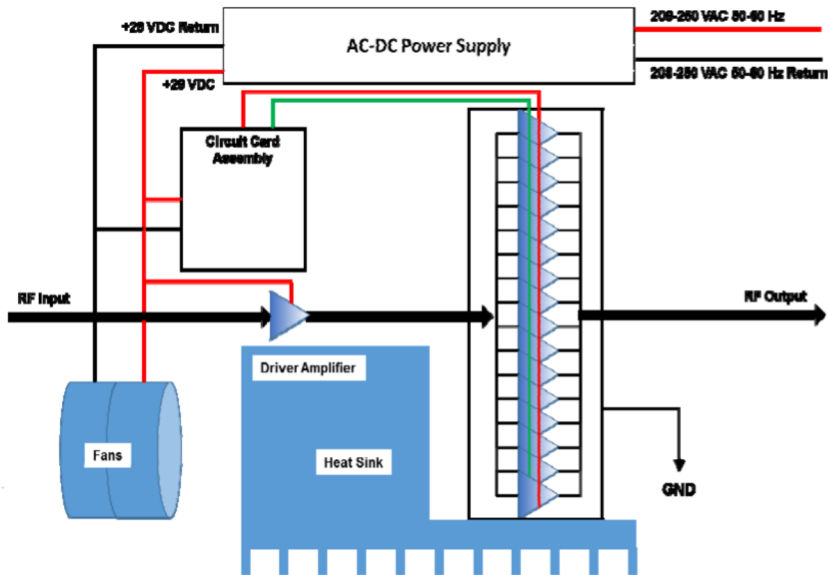

I/O Port	Label	Description
RF In	N/A	SMA Female RF Input
RF Out	N/A	N type coax
208-250 VAC	N/A	IEC 320-Standard Sheet C13 straight female connector with Retaining Clip

Performance Plots – Large Signal

Test conditions unless otherwise noted: $V_D = +28V$, $I_{DQ} = 9.6 A$, Clamp Temp. = +25 °C

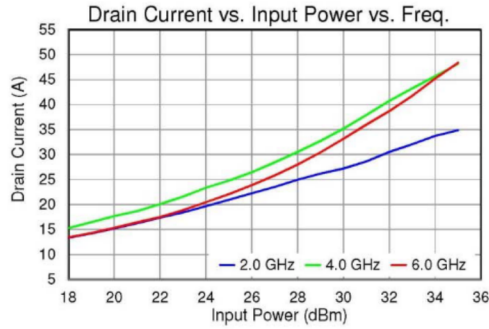
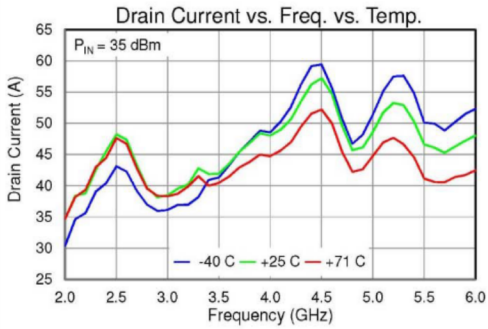
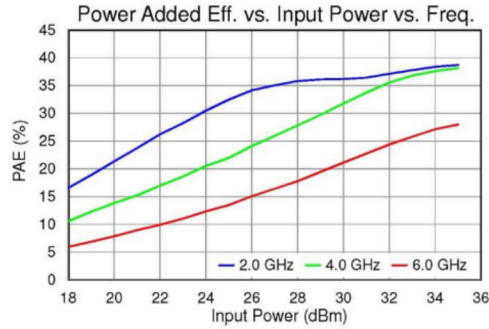
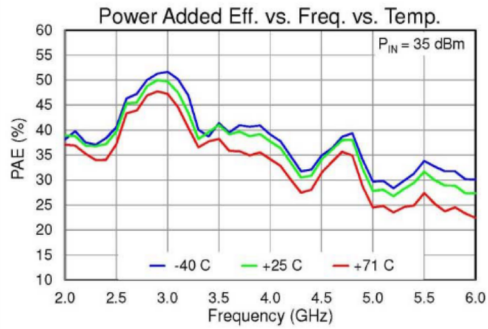
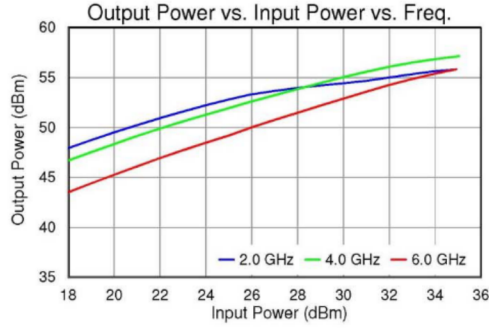
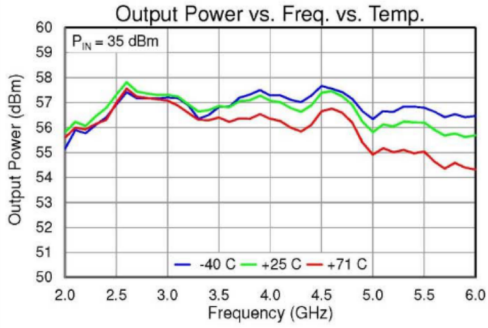

Performance Plots – Large Signal

Test conditions unless otherwise noted: $V_D = +28V$, $I_{DQ} = 9.6 A$, Clamp Temp. = +25 °C

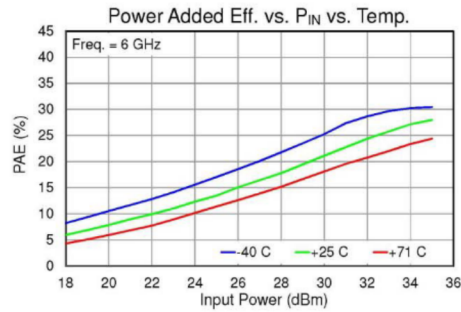
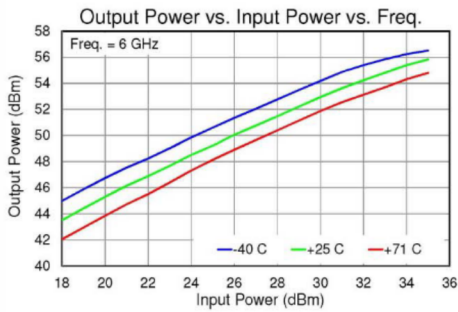
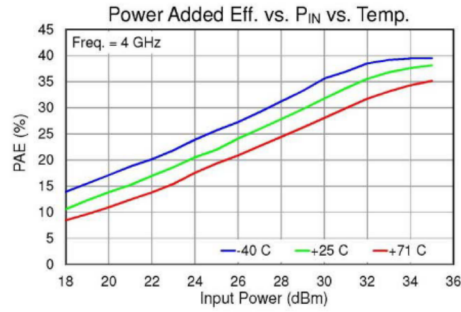
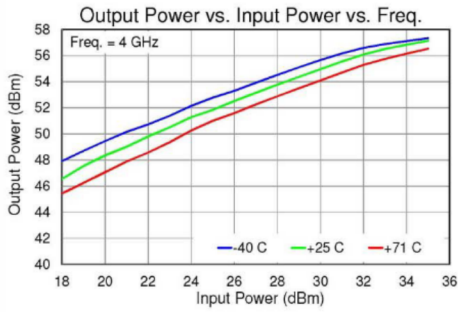
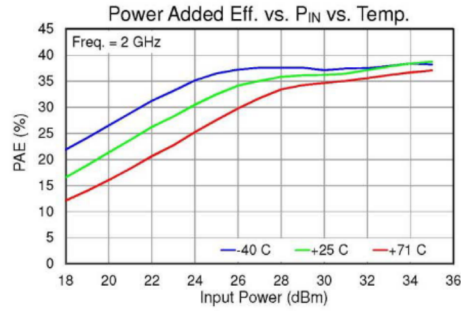
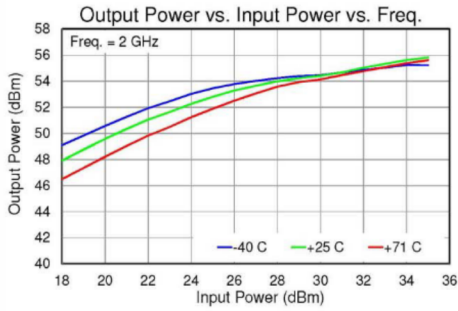

Performance Plots – Harmonics and Small Signal

Test conditions unless otherwise noted: $V_D = +28V$, $I_{DQ} = 9.6 A$, Clamp Temp. = $+25^\circ C$

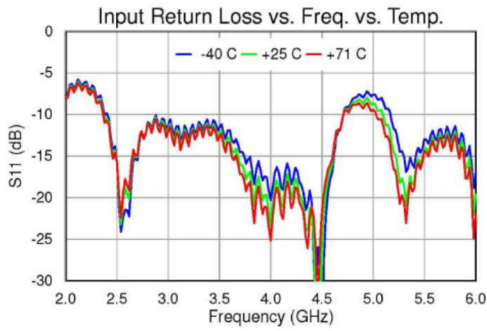
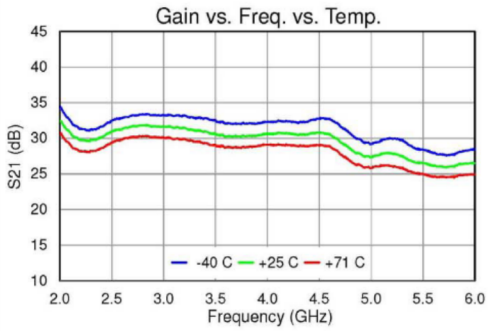
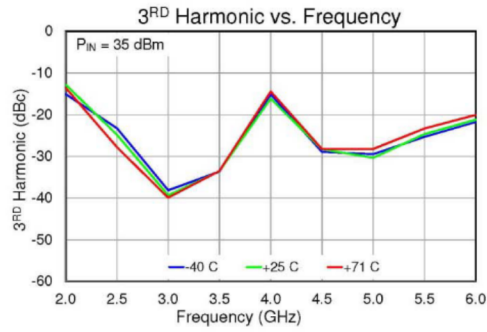
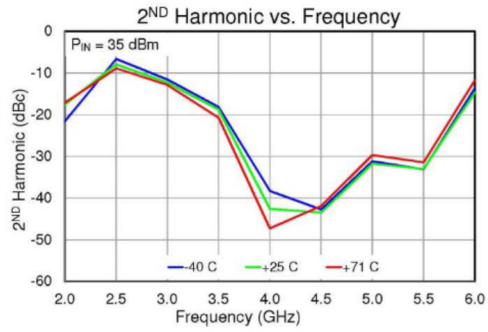

Package Marking and Dimensions

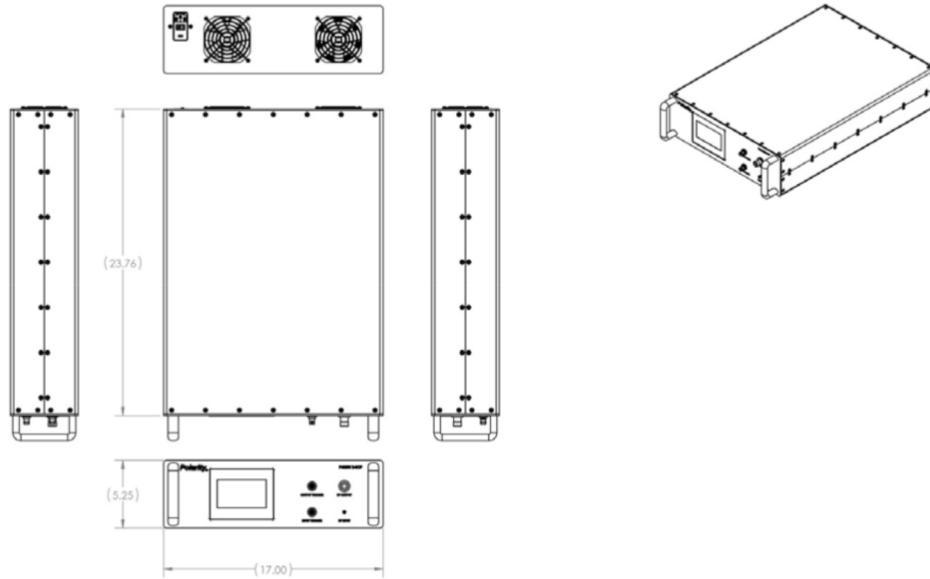

Handling Precautions

Contact Information

For the latest specifications, additional product information, worldwide sales and distribution locations:

Tel: 916-635-3050 x221

Web: www.polarity.net

Email: sales@polarity.net

For technical questions and application information: Email: sales@polarity.net
