

**Proprietary notice**

The data and prices contained within this document are the proprietary data of Cobham SATCOM, Land Systems, Patriot Products Inc. Neither the document nor the information contained within shall be used, reproduced, or disclosed to others without the written authorization of Cobham SATCOM, Land Systems, Patriot Products Inc.

Professor D. Campbell  
Cornell University  
Dept of Astronomy  
528 Space Sciences Building  
Cornell University  
Ithaca  
NY 14853  
USA

23<sup>rd</sup> Oct 2009

**Patriot Antenna Systems Firm fixed price proposal for a 12m VLBI capable  
Antenna**

Dear Professor Campbell

On behalf of Patriot Antenna Systems we are pleased to provide you with the following updated firm fixed price proposal for a Patriot high performance 12.1m, VLBI application, full motion, dual shaped cassegrain antenna, together with a description of Patriot's engineering capabilities and experience.

The first of Patriot's larger antennas was delivered to NASA for the DSN array project, it was designed for use at up to 32 GHz. In its standard form a precision Jack screw is used in elevation and a twin motor, torque biased, zero backlash gear drive system is used for azimuth however other configurations are also available. Unprecedented 26 bit encoders are used for exceptional accuracy for pointing and tracking feedback together with a state of the art motor drive and control system.

Since then we made several significant improvements to our design and have built four more 12m systems, one for AUT in New Zealand and a second one in a prime focus configuration for CSIRO in Australia for their feed development activity for ASKAP - the Australian SKA development work, and one for Auckland University. The fourth one is for Geosciences Australia and is under construction now. We presently have 6 more 12m systems on order and under construction, two more for Australia and three for another NASA project and one for MIT/Haystacks.

Many of these are for VLBI applications, and include the latest maximum movement speeds we can offer i.e. 5 deg/sec in Az and 1.25Deg/Sec average in Elevation. Also we can supply a new S/X band feed (and matching LNAs) that we have designed for present VLBI applications.

We hope that this is sufficient to demonstrate Patriot Antenna Systems competitive advantages and capabilities. If you have any questions at all then please contact me, we are looking forward to building an antenna for you.

We have looked at our existing workload and are convinced that we can fit this 12m system for you into our production planning so that we could have the system delivered and fully installed and commissioned by around Feb / Mar 2010, provided we receive your instructions in Nov 09.

Yours sincerely

*Peter Shield*

For Cobham/Patriot Antenna Systems  
Tel 450 424 5666

## **Table of Contents**

	Page number
Company information, heritage and Past performance	4
Patriots Key staff	6
ISO Certification	7
12m Antenna Detailed Description	8
Specification and compliance tables	14
Mechanical details including foundation drawing	16
Main System Interfaces	21
Axes position control electronics detailed description and operation modes	23
Examples of thorough design employed by Patriot Antenna Systems	42
Maintenance details	46
Recommended 12m antenna system spare parts list	50
Some of Patriots Antenna systems facilities and completed antenna pictures	51
Photos of antenna packed for sea freight	56
FFP price quotation	57

## **Patriot, company information, heritage and Past performance**

Patriot Antenna Systems is a world-class manufacturer of antenna systems and is based in Albion, Michigan, located 75 miles west of Detroit and 150 miles east of Chicago. This location, in the midst of the largest industrial manufacturing area in the world, provides Patriot with unparalleled access to a wide network of supporting subcontractors and transportation links. Patriot has a 300,000 square ft facility dedicated to the design and production of some of the most competitive and advanced antennas anywhere, with antenna sizes ranging from less than 1m up to over 18m in diameter. The industry's most advanced manufacturing facilities are found at Patriot including: The most accurate and efficient stretch and vacuum forming technology, 2 powder paint coat lines, extensive metal stamping and pressing facilities with 23 large presses of up to 1250 tons, 2 large CNC machining facilities, the largest (in the USA) *Mitsubishi* programmable 5 axis laser cutter/welder is used for trimming to shape antenna panels and capable of cutting up to 72 by 120 inch sections. A new large *Flow* water jet cutter is used for fabrication of whole stacks of radial antenna beams, this can cut up to an 8 inch thick stack of radial beams over a 24 foot by 6 ft bed at one pass (a whole antenna's worth). Advanced *SMX* laser and *GEODETICS* photogrammetric measurement of antenna surfaces are used. All this production capability results in the most cost effective antenna manufacturing available.

In addition to the advanced facilities Patriot Antennas Systems employs a staff of engineers and support personnel with all of the required expertise in Antenna RF, electrical and antenna mechanical engineering to provide a guarantee of successful project implementation. Some of these key staff have been previously involved with larger antennas than these for use at high frequencies and with a wide variety of mechanical control systems. Specific relevant staff experiences are as below:

- Design, manufacture and installation of Offset, Prime Focus and Dual Reflector Optics
- Design, manufacture and installation of antennas ranging from 1.2m to 100m in size
- Design, manufacture and installation of Full Motion and High Wind antenna systems
- Design/testing of L Band, S Band, C Band, Ku Band, DBS Band and Ka Band antennas and feed systems including dual band systems
- Photogrammetric and laser measurement of antenna surfaces
- Project Engineering and Management of contracts with values ranging from \$150k to \$10M

Patriot Antenna Systems have extensive Ka band experience with more than 10,000 deployed Ka band small VSAT terminals and the first in the industry Ka band type approval. Patriot's range of antennas includes 26 separate type approvals with more already applied for.

Patriot is now a part of the Cobham PLC organisation, a \$2Bn 10,000 employee corporation. Cobham plc is an international company engaged in the development, delivery and support of advanced aerospace and defense systems for land, sea and air.



**Patriot major communications programs and expertise including some specific examples:**

- Have designed and delivered the NASA JPL, 12.192m 32GHz, DSN array prototype antenna.
- Have recently developed and delivered antennas including a 4.8m XTAR hub antenna and, 9.4m and 12m commercial antennas
- Pas-8 / Pas-2 Patriot provided 100-4.5 meter antennas, 200-3.8 meter antennas, and 1000-3.1 meter antennas with multi-beam feeds to program recipients located in the Pacific Ocean Region. Allowing them to look at both satellites.
- Galaxy-IX Patriot provided 2000-3.8 meter antennas to program recipients in North America. Galaxy-VII Patriot provided 5000-3.8 meter antennas for this program.
- Pas-5 Patriot provided 2000-3.1 meter antennas to program recipients
- AMC-1/4 (formerly GE-1/4) Patriot provided 1500-3.8 meter antennas with multi-beam feeds to allow broadcasters to access both of the AMC-1 and AMC-4 satellites.
- Experience with using all the industries standard major subsystems and components such as control systems, De-icing systems, RF subsystems etc.
- Experienced with NASA and military applications.
- Have installed a 12m, 32GHz radio telescope for New Zealand that includes VLBI applications.
- Have installed a 12m antenna for CSIRO for ASKAP focal plane array feed developments for the Australian SKA
- We are now building 6 more 12m systems including 3 for The geosciences VLBI project in Australia.

## **Patriots Key staff Resumes:**

### **Mr. Dave Provencher, President Cobham Patriot products**

- Responsible for the Trackstar and Patriot product groups within Cobham, strategic company direction and the present growth into full earth station antenna systems and larger tracking antennas.

### **Mr. Mike Kerekes, Program Manager**

- 10+ years project and program management. Previous experience includes 20+ years in the automotive industry focusing on program management, quality management, and lean manufacturing, responsible for program management for large antenna projects within Patriot.

### **Mr Jose Perez**

- VP Global Business Development, responsible for Patriot worldwide business development. Senior level sales and marketing executive with 35 years of experience with multinationals including Bell & Howell, Voicemail International and Andrew Corporation.

### **Mr. Kevin Sinclair Senior Mechanical design Engineer Patriot antenna system Inc**

- 24 years experience with antennas and structures designs, expertise in photogrammetry and FEA, the holder of several patents

### **Dr. Mark Godwin, Consultant to Patriot Antennas**

- 30+ years in RF engineering and telecommunications in both commercial and academic activities. RF design, analysis, testing and holographic measurement of large antenna surfaces. Numerous publications and awards including recognition by NASA for work done on the 70m Deep Space Network Antennas in preparation for communication with *Voyager 2* as it passed Neptune.

### **Tim Voorheis**

- **Mechanical Engineering** Specialized in mechanical design and FEA/ Structural analysis, and product quality improvements

### **Boris Yim**

- **Masters of Science in Aerospace** He is specialized in Astrodynamics, systems engineering, Dynamics control , CAD , FEA and Numerical computations

### **Dr. Rami Adada, Senior Antenna Engineer Patriot Antenna Systems**

- Senior antenna and feed design experience. Expertise in CST's Microwave Studio for feed component design and TICRA's GRASP software for reflector design. He has authored and co-authored 10 publications on electromagnetic and communications related topics and has 1 patent application.

### **Mr. Peter Shield, President InterTronic Solutions**

- Sales and Marketing contact for key accounts and applications for large antennas in programs such as military and commercial satellite communications, VLBI, Radio Astronomy (NASA etc) for all Patriot Antenna Systems products. 30 years in senior aerospace engineering, marketing and business leadership positions.

ISO status



# CERTIFICATE OF REGISTRATION

Certificate No. US-1914b

**Patriot Antenna Systems, Inc.**

**704 North Clark Street, Albion, MI**

The Quality Management System is registered to:

**ISO 9001:2000**

The Quality Management System is applicable to:

**Patriot Antenna Systems:  
Design and manufacture of satellite antennas.**

**Patriot Industries, a Division of Patriot Antenna Systems, Inc.:  
Design and manufacture of automotive prototype, production stamping and fabrication.**

**Patriot Powder Coaters, a Division of Patriot Antenna Systems, Inc.:  
Custom powder coatings of metal products.**

Initial Certificate Date: January 9, 2003  
Certificate Issue Date: December 11, 2003  
Certificate Renewal Date: November 21, 2006

  
Authorized Signatory

The approval is subject to the organization maintaining their system in accordance with Intertek Systems Certification's rules and regulations for certification.

**Intertek** Systems Certification

Intertek Testing Services N.S. Inc.  
Burlington, MA, USA



National Accreditation Program



## 12m Antenna Detailed Description

The 12m antennas described herein are based on Patriot's new 12m standard large reflector antenna shown in the 12m commercial data sheet below.

### **12 Meter Tx / Rx Earth Station**



## **12 Meter**

### *Features*

- C, Ku, Ka, and X-Band feed options
- 2-Port or 4-Port configurations
- CP/LP switchable feeds
- Circular Foundation Interface
- Full line of options to meet any requirement
- No on site panel alignments required
- Installation Teams and Supervisors Available
- Factory assembled mount reduces installation time
- High Wind and Full Motion options available
- Extended C-Band Feeds

### *Description*

**Patriot antennas have superior surface accuracy.** Patriot's antenna reflectors incorporate precision stretch formed panels into very stiff backing structures. To insure quality and performance Patriot panels are inspected for R.M.S. accuracy using the latest in laser measurement techniques.

**Patriot antennas have superior corrosion resistance.** All reflector and mount parts are produced from high quality materials and treated for corrosion resistance by powder coat paint, epoxy paint or hot dip galvanizing as appropriate for each component. All hardware is stainless steel or hot dip galvanized depending on size an application.

**Patriot antennas are designed and built to weather the storm.** All Patriot Large Aperture Antennas are capable of surviving winds up to 125 mph as standard. High Wind designs are also available for areas that experience severe winds.



# 12 Meter Tx / Rx Earth Station

General Specifications		
Directive Efficiency	85%	
Pointing Accuracy	0.005° rms	
Surface Accuracy	0.012" rms	
Slew Rate AZ	3°/sec	
Slew Rate EL	0.7°/sec	
Acceleration Rate	2°/sec <sup>2</sup>	
Control Panel Servo System	includes speed and position loops	
Encoders	26 bit	
Interface	Ethernet or RS 485	
Typical RF Specifications		
Geometry	Dual Shaped Cassegrain, Sub Reflector Subtended angle 100°	
Feed Options	C, X, Ku, Ka band	
Optimization	High Efficiency Shaped Cassegrain	
Mechanical Specifications		
Antenna Diameter	12m	
Antenna Type	Cassegrain	
Elevation Travel	5°-90°	
Azimuth Travel	+/- 270° Continuous	
Drive System: Elevation	Ball Screw Actuator with redundant brake	
Drive System: Azimuth	Torque biased dual pinion drive	
Mount Type	Full Motion	
Mount material and finish	Steel, painted white	
Structure material and finish	Aluminium, painted white as required	
Reflector material and finish	Aluminium, painted white	
Environmental Specifications	Standard	Metric
Operational Winds	35 mph, Drive to stow 50mph	57 kph, Drive to stow 82 kph
Survival Winds	100 mph at Stow	163 kph at Stow
Ambient Temperature	Operational: +5° to +122°F Survival: -22° to +140°F	-15° to 50°C -30° to +60°C
Rain	Up to 4 in/h	10 cm/h
Relative Humidity	0% to 100% with condensation	
Solar Radiation	360 BTU/h/ft <sup>2</sup>	1000 Kcal/h/m <sup>2</sup>
Radial Ice (Survival)	1 in all surfaces	2.5 cm
Shock and Vibration	As occurred during shipment	
Corrosive Atmosphere	As encountered in coastal regions and/or heavily industrialized areas	
Seismic (Survival)	0.3 G's Horizontal, 1.0 G's vertical	

The first 12m



The second 12m



Cobham SATCOM Land System Patriot Products Phone (517) 629-5990 – Fax (517) 629-6690 – 704 North Clark St. – Albion, MI 49224 – [www.sepatriot.com](http://www.sepatriot.com)

The third one

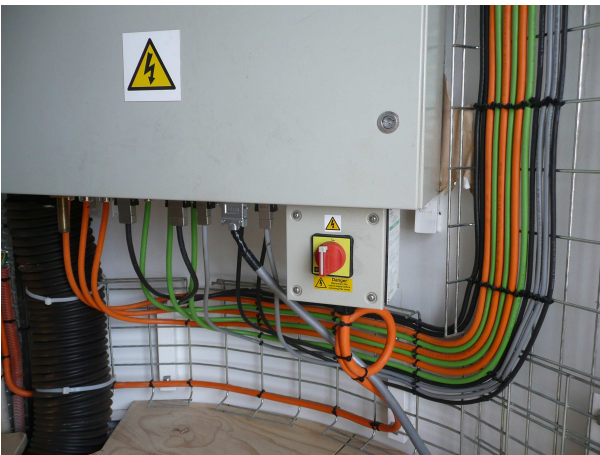



The forth one in Tasmania



Showing the pedestal heat shields fitted – a standard fitment for all astronomy grade systems.

**Patriot Antennas 12m design with a jack drive elevation system**

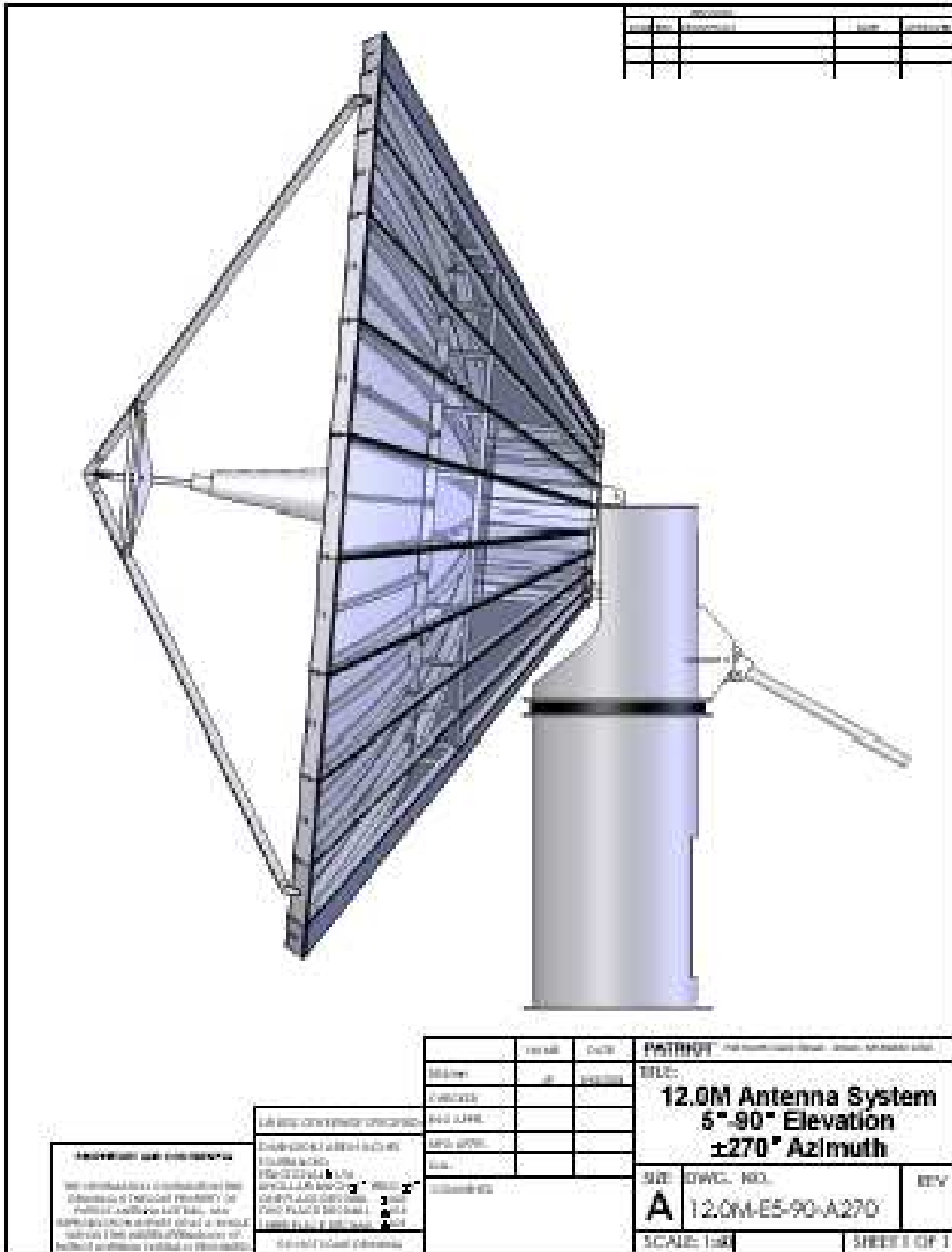

## **Detailed description of 12m antenna system proposed**

For this proposal we are suggesting our standard 12m system as is described below including our existing precision control system as that is also highly suited to VLBI, astronomy and deep space applications.

### **Equipment Provided**

The following major subsystems are included in the proposed system.

- 12.192 Meter Antenna System including:
  - Anchor bolt and template kit
  - 12m Aluminium main reflector with aluminium backing structure and tie downs for extreme wind conditions.
  - Composite Sub-reflector and support struts
  - +/-270 degree (tracking) continuous twin motor/gearbox torque biased azimuth drive
  - 5 to 88 degree (tracking) continuous Ball Screw Elevation drive.
  - Servo electronics assembly and housing, Interface Kit with AC drive motors for Azimuth and Elevation. Two motors used in Az for torque biasing and one in elevation.
  - Complete RFI tight controller cabinet fitted with all the safety features, interfaces and the software required tested and loaded into the three Unidrive SP inverter drives (Emerson / Control Techniques).
  - 26 bit absolute position Encoders
  - Main and backup limit switches and cabling
  - Aircraft Warning Lights and Lightning Protection
  - Installation and assembly supervision at site (Extra cost)
  - Pedestal sun-shields for the astronomy applications
  - Cable wrap system with sufficient space for customers cables etc
  - Tie down loops for additional stability in extreme winds on rear of reflector
  - Additional cable access holes and ports on turning head floor to pedestal access and on side of pedestal.
  - Theodolite target on top of turning head
  -

Optional extras include feeds, LNAs, low loss waveguide test injection loop couplers on the feed output ports, waveguide dehydrator inlet ports, external to pedestal access ladder for easy access to elevation gear and back of antenna hub, fibre converters to enable fibre optic control, hub and pedestal environmental control systems, de-icing equipment, and special custom fittings and brackets etc for customer supplied equipment.



**Standard proposed specifications for this application of our 12.1m antenna**

- Electrical:** See below
- Environmental:** As per commercial data sheet above
- General Mechanical:** As per commercial data sheet above and descriptions below except for elevation range under closed loop control is 5 to 88 Deg (goes to 90Deg for stow) and speeds of movements as described below. Also acceleration rate is set to 1.33deg/sec/sec max in azimuth and 2.6deg/sec/sec max in elevation
- Pointing accuracy target:** 0.005 Degrees at 30MPH max wind
- Reflector surface accuracy:** 0.015 inches RMS Typical, all causes for use to well beyond 17GHz
- Antenna F/D** 0.375
- Shape:** Dual shaped cassegrain for high efficiency
- Speed of movement:** For this application we have offered 5 Deg / Sec max in Azimuth and an average for elevation of 1.25 Deg/sec, as this is what our current design can do and this is what is being used for all the VLBI applications.
- Antenna operation modes** See text

## Foundation

To be built in accordance with the drawing below.

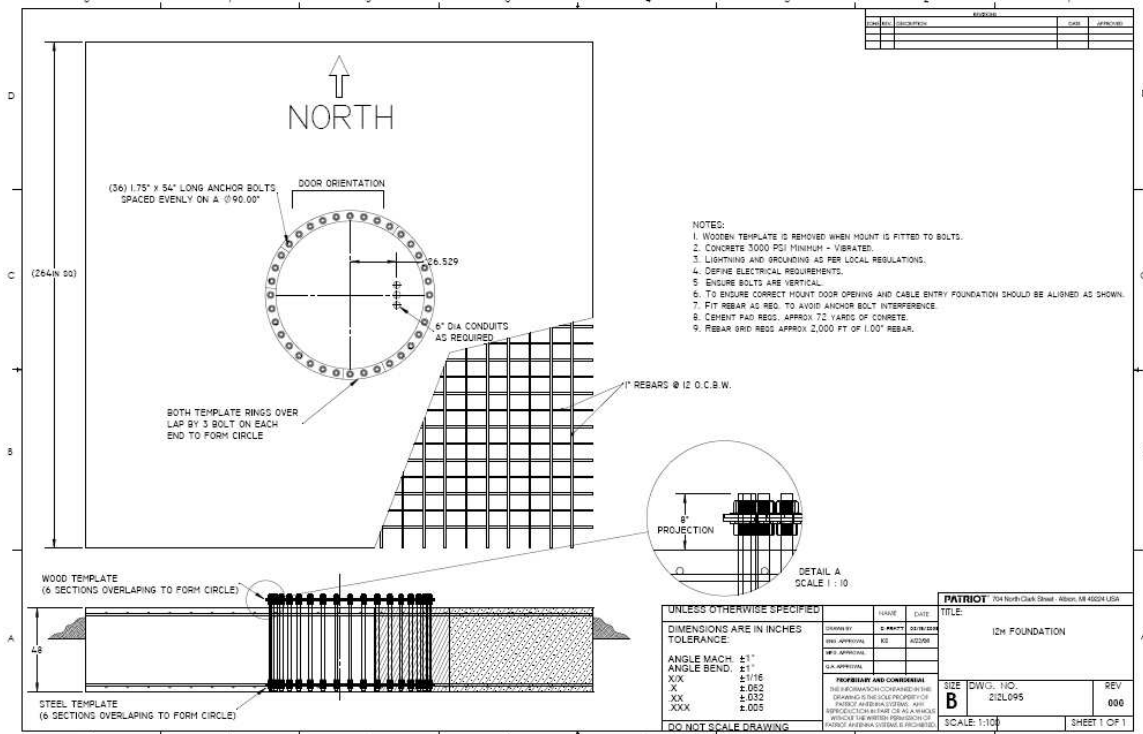

## Reflector

The reflector system uses an aluminum support system of a rigid back-up structure consisting of a rigid hub, precision support trusses. As the antenna must be operable in all elevation angles, the structure is designed such that it does not significantly distort due to gravitational loadings or the extreme wind loadings. The aluminum reflector panels are manufactured to very close tolerances by use of Patriots advanced and industry proven stretch form technology and are then laser cut to shape. The radial beams and accurate support stringers are cut on Patriots new high speed water jet cutter. Panels are cleaned and powder coat painted with a white heat diffusive finish. The panels are designed to survive the required wind loads. The panels are manufactured to a surface accuracy of 0.008 inches rms. Dimensional accuracy of the panels is controlled within +/- 0.030 inches to ensure proper fit and panel gaps at assembly. The last few systems we have built have had measured initial RMS values in the range 0.011 to 0.014 inches.

## Antenna geometry

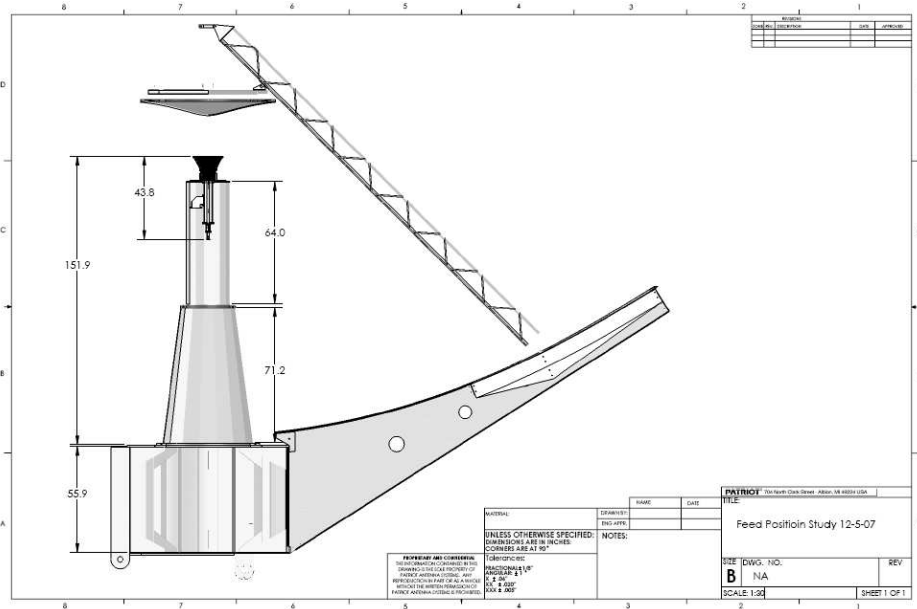

## Feeds

A variety of feeds can be fitted to these antennas ranging from conventional communications types from C band to upper Ka band including high performance low cross pol types. For Deep space and astronomy applications cryogenically cooled feeds can be fitted as there is sufficient cable wrap space for the cryogenic tubing etc.

We have our own design of an all aluminum room temperature S/X band VLBI feed. This design provides dual polarization CP outputs in both the 2.1 to 2.4 GHz and 8.1 to 9.2 GHz ranges. The 4 interface flanges are WR430 and WR112 standard flanges. We can also supply MITEQ matching S Band 30 degK and X band 50 degK LNAs to suit if required. We do not however supply Cryogenic LNAs or feed systems.

The antenna optics we believe suit the wideband Vivaldi type feeds also being evaluated for wideband VLBI. With the S/X feed is supplied a feed cone and feed support structure.

## Optional MITEQ LNAs

RF Frequency Range	2.1/2.2 – 2.4 GHz
Gain	60 dB min.
Gain Flatness	± 0.5 dB max.
Noise Temp.	30°K max.
Input VSWR	1.25:1 max. (over 2.2-2.4)
Output VSWR	1.5:1 max.
Power Out 1 dB Compression	+10 dBm min.
DC Power	300 mA nominal @ +15V
Outline Drawing	148029

RF Frequency Range	8.1 – 9.1 GHz
Gain	48 dB min.
Gain Flatness	± 1 dB max.
Noise Temp.	50°K max.
Input VSWR	1.5:1 max.
Output VSWR	1.5:1 max.
Power Out 1 dB Compression	+12 dBm min.
DC Power	225 mA nominal @ +15V
Outline Drawing	138968-2

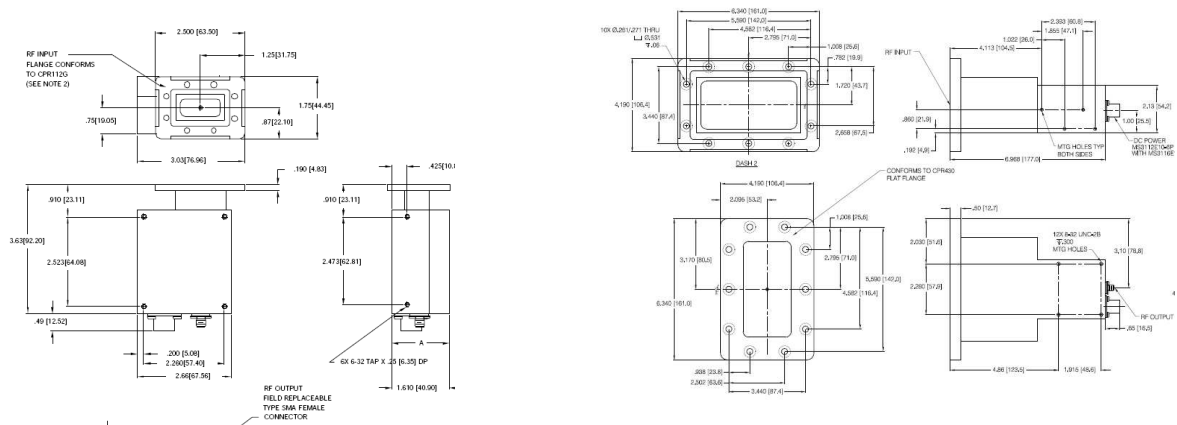

Cross section of reflector and feed cone system showing typical space available for customers own feed systems

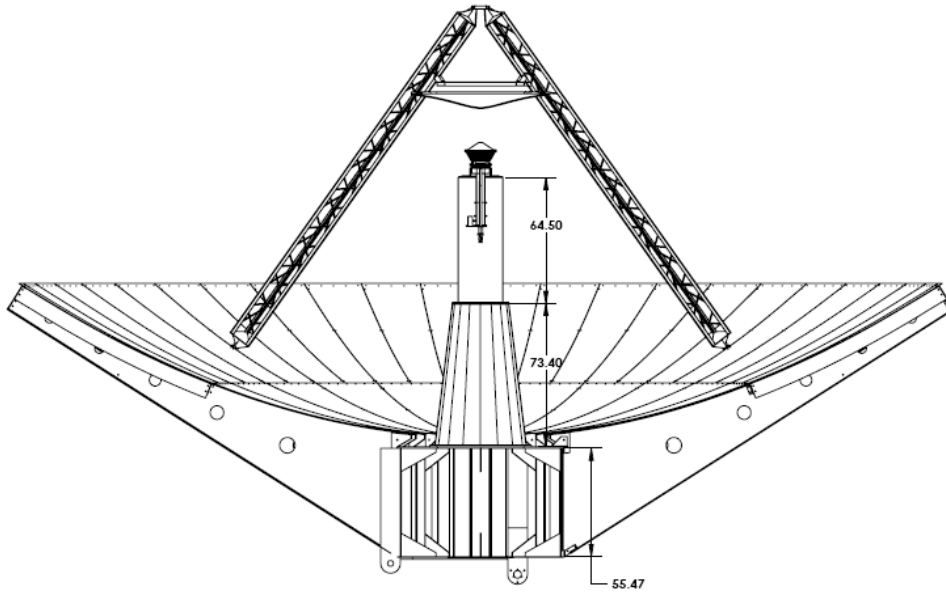

**Feed support cone detail showing Patriot S/X band feed fitted**

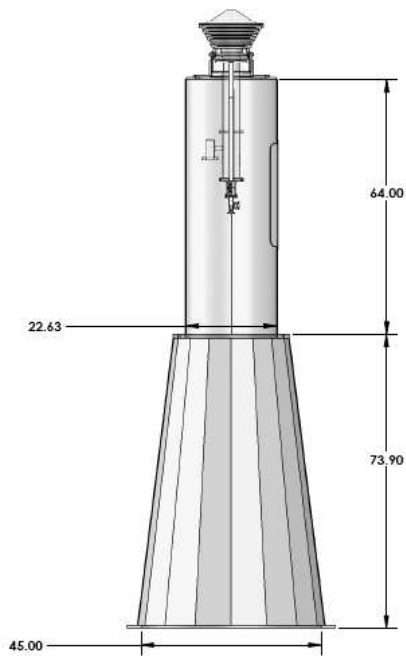

### **Subreflector Support**

The quadripod structure utilizes four rectangular members for support legs which are joined at the apex by the subreflector support structure. The individual members and resulting assembly are designed for a high stiffness to weight ratio and minimal blockage.

### **Subreflector**

This is a carbon fiber, shaped composite sub reflector, and its typical surface accuracy is 0.004 inches RMS. It is accurately positioned for best efficiency. It is supported by the sub reflector quadripod structure.

### **Turning Head**

The Turning Head is a welded box and beam construction with an integrated machined boss to interface with the azimuth bearing/gear assembly. The elevation pillow block mounting surfaces of the Turning Head arms are machined level and parallel to the machined azimuth bearing interface flange of the Turning Head base. In order to speed up field alignment, the Turning Head arm connection to the Turning Head base is designed to be a flange type connection machined parallel to the azimuth bearing mounting flange. The alignment of Turning Head components is verified during shop proof assembly.

The Turning Head base provides machined mounting flanges for the elevation gearboxes, shock absorbers, and stow pin assembly. Special adjusting screws that facilitate jacking the gearboxes to position as well as providing the necessary hold down feature achieve the alignment of the pinions to the elevation gear.

This structure also provides machined mounting pads for azimuth gearboxes. Location of azimuth gearboxes, coupled with external gearing of the azimuth bearing assembly, provides easy access for maintainability of the gearboxes and azimuth gear. Stiffeners are provided at maximum stress points to minimize local distortions. A special feature of this structure is that, because of the machining tolerances achieved in the factory, adjustments of the gearboxes are minimized during field installation. Outboard bearing supports are provided for azimuth and elevation drive pinions in order to increase life and stiffness for the respective drive systems.

### **Elevation Gear**

The elevation drive consists of one precision, anti-backlash ball screw actuator, gearboxes and motor. The ball screw actuator is oversized to provide long life and require minimum maintenance. The gearbox provides the proper ratio to meet the drive speed requirements. At any elevation angle the drive is permanently in compression hence eliminating backlash and this system has been proven to work very well. Life testing has been conducted on this elevation system that demonstrated (for a NASA application) over 20 years expected life for the ball screw jack. The ball screw jack is also extremely easy to replace should maintenance or replacement ever be needed. The extendable boot over the large jack screw is a regular maintenance item and is also easy and low cost to replace.

### **Elevation Bearings and Pillow Blocks**

The elevation stub shafts are supported by self-aligning spherical roller bearings (SKF) with minimal internal clearance. These bearings are housed in fabricated steel pillow blocks designed for strength as well as stiffness, instead of standard cast pillow blocks. The bearings are pre-loaded in the shop by forcing the bearing up the taper of the shaft, thus removing any internal clearance. A lock nut is installed at the end of the shaft resting on the inner flange of the bearing to secure and maintain the pre-load.

### **Azimuth Drive**

The azimuth drive includes an integral pinion, hand wheel with interlocks, fail-safe brake, and AC drive motors and gearboxes. The gearboxes, uses helical gearing for efficiency, smooth operation and long life. The gearboxes uses submerged oil bath lubrication systems with a single all season oil.

The brakes are mounted at the end of the drive assembly for ease of maintenance. Alternatively, they can be through shaft mounted between the motor and gearbox. Mounting of the brakes directly on the gearbox has the advantage that they are available for holding the antenna even if the motors are removed.

### **Brakes**

Each drive is equipped with a spring set electrical release fail-safe brake by Sterns. The brakes are sized to hold the antenna at wind loads up to 100 mph at the stow position.

### **Electromechanical Limit Switches**

Pre-limit and final limit switches are provided on each axis to prevent over travel. For redundancy, pre-limits and final limits are also provided in the software.

The first, or pre-limit, operation prevents application of drive power in the direction of the encountered limit. Final limit switch operation removes power from the drive motors and sets the brakes. The antenna must be manually driven out of the final limit, the pre and final limit functions are obtained from cam operated switches on each axis.

### **Azimuth and Elevation Cable Wraps**

Electrical cabling that crosses the azimuth axis goes through an azimuth cable wrap that accommodates the antenna azimuth travel.

The azimuth cable wrap is capable of carrying all the Patriot supplied cables and customers additional requirements and is conservatively designed to operate well beyond  $\pm 270$  degree antenna azimuth travel.

The elevation cable wrap, mounted inboard of one elevation bearing, carries power, customer's cabling, and signal cables across the elevation axis. One end of the cable bundle is secured to the platform and the other end is clamped to the rotating Reflector Support Structure so that the mid-point of the flex section passes through the elevation



axis. The cables are installed so they are straight (unbent) when the antenna is at a 45-degree elevation to keep cable flexure to an absolute minimum. Cross axis waveguide runs can also be incorporated if required.

### Azimuth cable wrap pictures

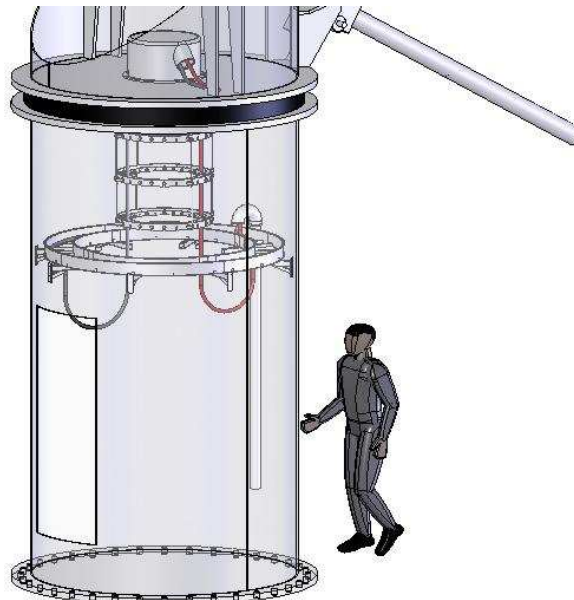
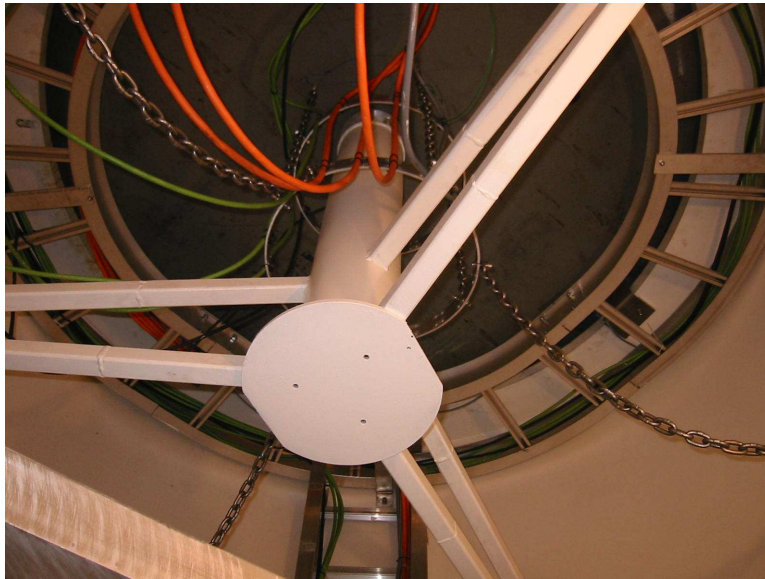

### **Emergency Switches**

A group of emergency switches and a group of safety switches are provided on the antenna for emergency situations and for routine maintenance modes. Emergency interlock drive disable switches are located in the following areas:

- a. Elevation drive area
- b. Azimuth drive area
- c. Access areas

Drive disable safety switches are provided to disable the drives when the drive system hand wheels are engaged. Operation of any of the safety devices results in removal of drive power from the motors and application of the brakes. The drive systems remain inoperative until the emergency switches are reset or the unsafe condition is corrected.

### **Fasteners**

All standard fasteners are ASTM A325 high strength. For special connections such as bearings and drive components, Grade 5 or Grade 8 hardware may be used with special corrosion treatment to avoid hydrogen embrittlement. Fasteners are either shop or field installed utilizing “turn-of-the nut” method to insure proper tension instead of torque wrench that is not reliable and difficult to inspect.

### **Surface Finish for Structural Steel**

The recommended surface finish system for this antenna’s steel structure is hot dip galvanized for all structures where this is practical. For steel structures that are too large or complicated for hot dip galvanizing it is recommended the structures are sand blasted to near white in accordance with prior to painting with a customer approved paint system. All aluminum structures including reflector panels will be painted white in accordance with the customer’s specifications. The antenna components are touched up in the field during installation. A procedure will be issued for the control and inspection of the surface finish, both for shop and field application.

## Main System Interfaces

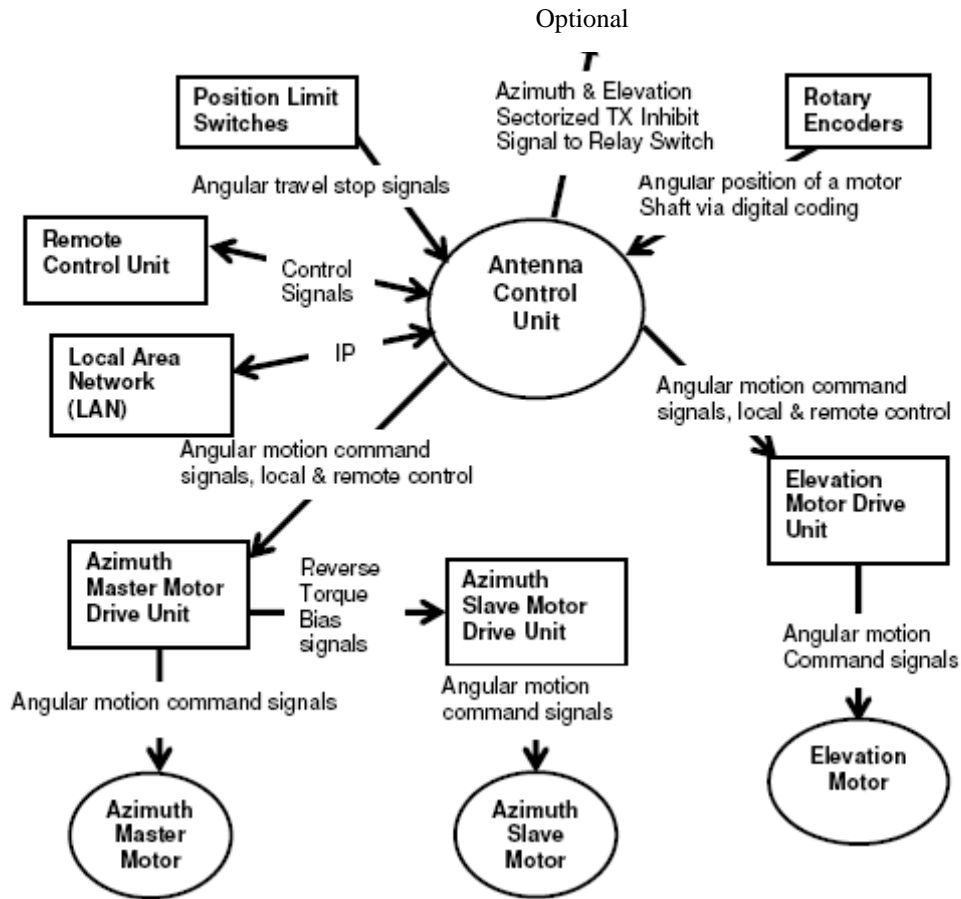

## Control and electrical system main diagram

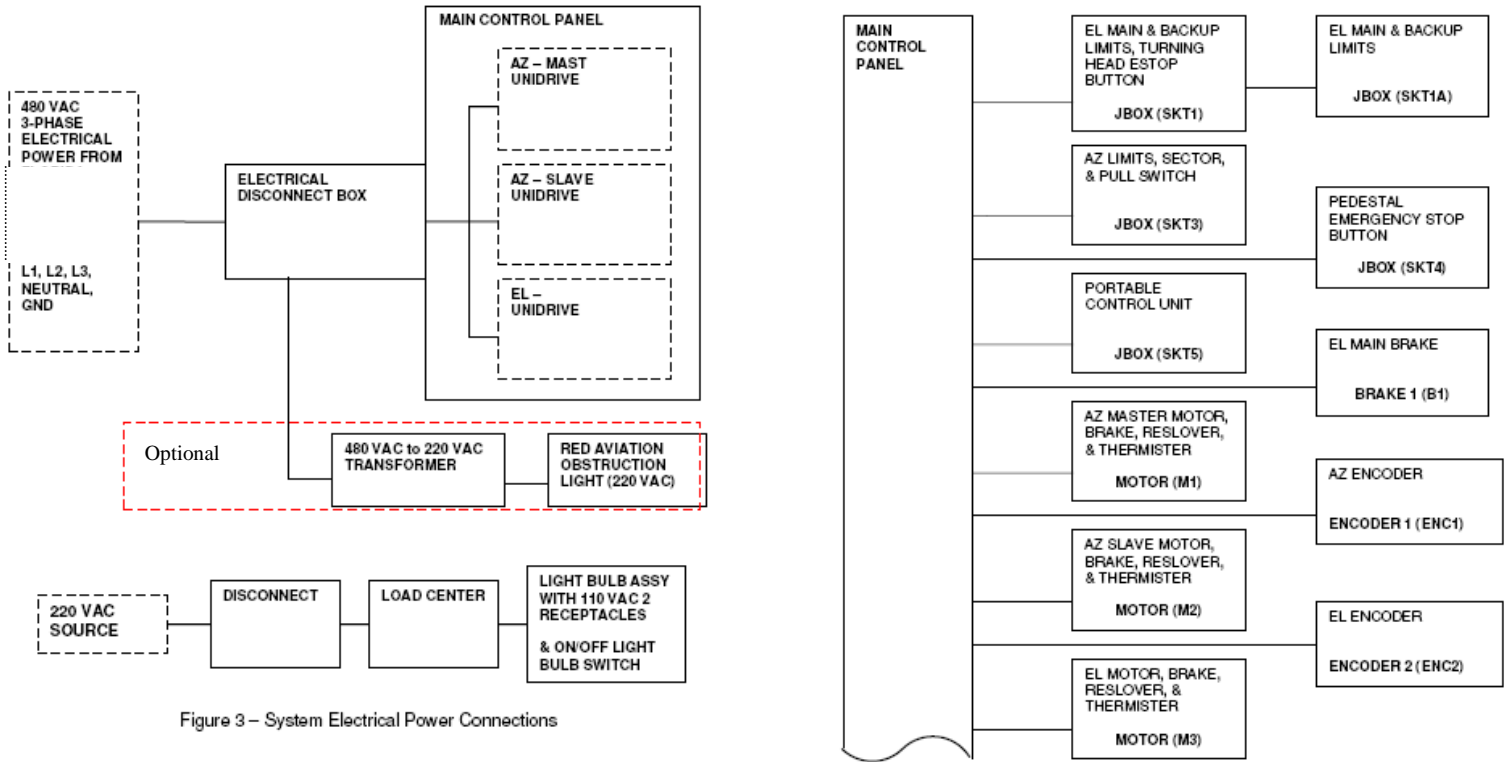
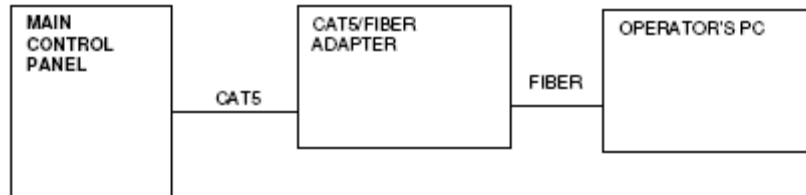

Figure 3 – System Electrical Power Connections

### Optional optical system communications connections:



### System main electric power required is:

408 volts 3 phase with a peak load of 16 KVA

## Axes position control electronics

The current design for speed and position control uses low cost COTS based, SP Unidrives, micro-processor controlled inverter drives supplied by Emerson Control Techniques. Three drives are used for our typical 12m applications, one for elevation and two for the azimuth motors which are driven in a torque bias mode to eliminate drive train backlash. These drives provide closed loop speed control using feedback from speed encoders fitted to the motor drive shafts.

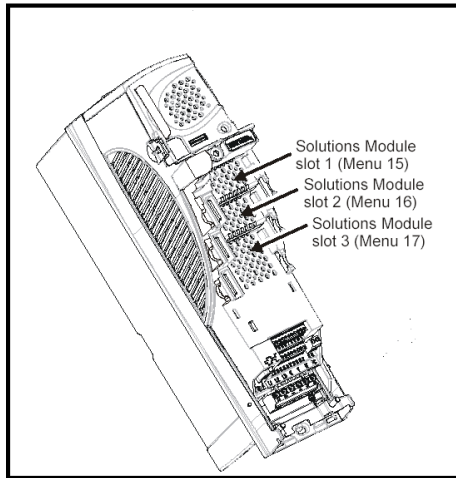

Closed loop position control is also implemented; this being one of the principal applications of the Unidrive SP inverter drives. Each Unidrive SP has three expansion slots into which various option modules can be fitted. Modules operate on the same clock as the inverter drive and have full access to all drive parameters. The elevation and one of the azimuth drives are fitted with an SM Universal Encoder module that enables it to read the angles output by the Heidenhain elevation and azimuth axis encoders. The data format produced by the encoders is EnDat which is a four wire serial interface.

The basic inverter drive contains firmware for simple position control applications. However for the present purpose it is necessary to fit each drive with Application Modules. These are additional processors hosted by the drives, which are user programmable in Drive Programming Language (DPL). Programmed tasks can be prioritized, the most time critical (such as position loop operations) are run at the highest level (POS0) whereas the least critical are run as BACKGROUND.

The position loops are implemented in Application Module firmware to generate velocity commands that are written to the speed loop resident in the basic drive firmware. The position loop is a PI controller with velocity feed forward. The speed loop with the drive is a PID controller and its torque command output is applied to a PI motor current controller.

Elevation and azimuth position command data is read into the Application Module firmware in a variety of formats including analogue voltage or current and all standard machine control serial data protocols such as ModBus, ProfiBus, etc.

The position control loops update every 4 ms.

Implementing the position loops as proposed has the advantage of using only standard off the shelf components. Also the entire position controller function is run from a single clock eliminating the timing problems often encountered when position and speed loop functions are executed on separate, unsynchronized processors.

### **Overview**

The controls industry has evolved networked solutions and equipment for the control and monitoring of hundreds or even thousands of machines performing synchronous, precision tasks, for example in large process plants. Controlling the an array of antennas to observe the sky poses much the same technical challenges and so the control solution proposed here draws heavily on proved available technology from the process control industry.

The Controller is a single enclosure and uses only widely available, COTS hardware. No custom antenna control unit (ACU) hardware, or separate computer, is required. All Controller software tasks are synchronized and are executed at intervals appropriate to their functions, one of the fastest being the position loop which typically runs every 4 ms, i.e. 250 times per second.

As common in process control, a Master/Slave control interface protocol is used, in which the antenna is the Slave. This protocol is implemented via a TCP/IP Ethernet interface, so that antennas can be networked directly. Antennas can be readily controlled and monitored by client application programs, and can support simultaneous multiple connections. Security and priority facilities are provided.

The Control System is designed to be synchronous. That is, each antenna has its own accurate clock which it uses to execute time-stamped track data downloaded to it ahead of time. Subsequently therefore, the instantaneous pointing of an antenna can be relied upon without having to read the antenna's position encoders, which in any case would introduce inaccuracies due to latency.

A number of features incorporated in the Controller are particularly relevant to array operation. Firstly, the Controller implements, in real time, pointing corrections calculated from a nine term pointing error model. These corrections are specific to each antenna and are required to accommodate the small but inevitable misalignments of the antenna axes. The advantage provided is that the network control system can broadcast identical pointing coordinates to all antennas, and does not have to pre-correct data individually for each antenna. Secondly, the Controller can be enabled to make automatic correction to elevation angles for atmospheric refraction.

Time-stamped coordinates can be downloaded to define a track for an antenna to follow, and offsets can be superimposed onto a running track. Data can be loaded for any time in the future and can be streamed to the Controller 'on the fly'.

Note that the Controller can accept position data as Azimuth and Elevation (Az/El) coordinates or as Right Ascension and Declination (RA/Dec) (J2000) coordinates.

When provided with a single RA/Dec coordinate pair, the antenna tracks that point on the sky. RA or Dec offsets can be introduced, for example to investigate the sky around a point being tracked. Alternatively, time-stamped RA/Dec data can be sent to the Controller. In this data mode, very much fewer data points are required to track objects such as planets.

A summary of the Controller's principal features is given below.

- Whole system is in a well proven RFI tight enclosure. This enclosure is housed inside the pedestal for an additional layer of screening
- State of the Art Motion Controller Technology for accurate positioning and tracking
- Acquisition and autotrack on any band (using tracking inputs from Customer supplied RF systems and feeds)
- Program points, manual and 2 line ELSET modes
- All Antenna Specific calculations and corrections are implemented in within the Controller
- Comprehensive Monitoring, Diagnostics, and Fault Reporting
- Ethernet TCP/IP multi-client Interface
- Built-in Pointing Correction for axes misalignments using a 9-term pointing error model
- Built-in Correction for Atmospheric Refraction if required
- Tracking from time tagged Azimuth and Elevation data files
- Tracking from time tagged Right Ascension and Declination data files
- Pointing offsets (Equatorial and Horizon Coordinates) superimposed on track profiles
- Built in real time clock synchronized to a network time server using the SNTP
- Capacity to handle control and monitoring (analogue and digital) of external equipment such as feeds and receivers.
- API for remote installation of software updates and modifications



## CONTROLLER PHYSICAL DESCRIPTION (4 drive 12m version)



The Controller is housed in a single RFI tight enclosure mounted in the antenna pedestal. See the photographs below for example of a typical unit.

The Controller power isolator is mounted in a small sub-enclosure to the bottom right of the main enclosure. This isolator can be padlocked in the OFF position.

Front panel controls and indicators are kept to a minimum as it is expected that the antenna will be controlled remotely, except for occasional service and maintenance. This also helps to reduce RFI emissions.

Front panel controls are as follows.

- Emergency Stop Button
- Function Switch with the following positions
  - REMOTE
  - OFF
  - STANDBY
  - OPERATE
- Power Indicator Light/Reset Button

The enclosure door is not interlocked as there are no exposed AC power terminals inside. This allows a suitably qualified engineer to access the motor drive keypads for maintenance purposes. Note that the drive keypads are programmed so that they display the elevation and azimuth angles by default on power up.

All connections to the Controller are via the bottom panel. Also mounted on the bottom panel is socket for connection of the pendant local unit which is used to drive the antenna when in LOCAL mode.

### **PENDANT LOCAL UNIT**

A pendant local unit is provided for simple local control of the antenna for maintenance purposes.

The pendant local unit connects to the Controller via 15m of flexible cable, which is sufficient to reach the turning head. With the Controller in Local Mode, toggle switches on the pendant local unit allow each axis to be driven at pre-set fast or slow speed. Note that the operator must hold the switches to maintain movement, i.e. the antenna stops when the switches are released.

An emergency stop button is mounted to the pendant local unit.

LEDs on the pendant local unit indicate the limit status. A soft limit is indicated by a flashing light. A continuous light indicates that a limit switch has been reached, although this is not possible in normal operation and with the limits set correctly.

### **MOTOR INVERTER DRIVES**

The servomotors are driven by fully digital, variable frequency, PWM drives.

A schematic of the digital current and speed loop for each motor is given below.

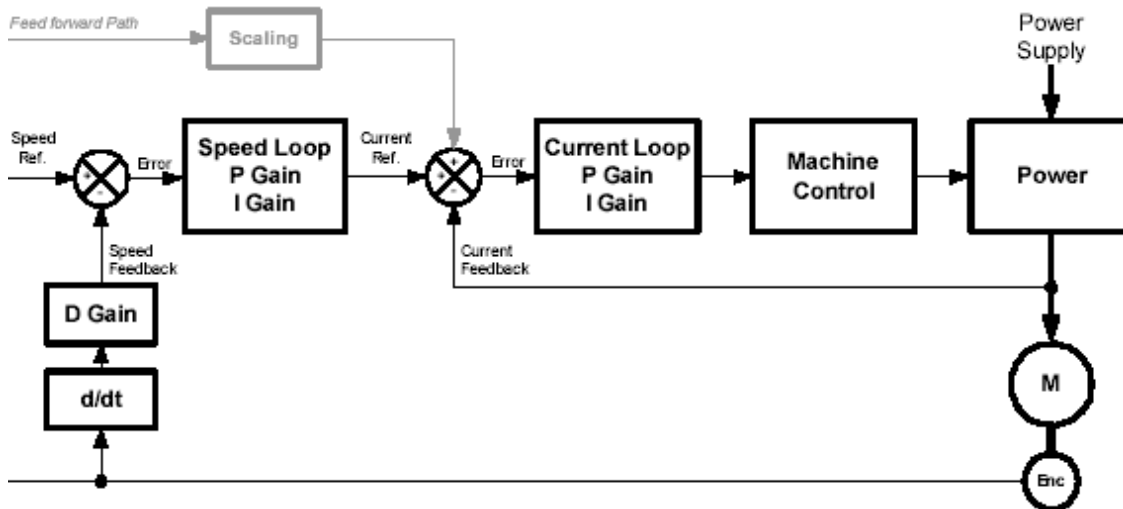

The motor current control loop is a PI loop within a PID speed loop. The latter takes its speed feedback from the motor shaft encoder. The input to the speed loop is a digital speed demand (0.001 rpm resolution). Torque feed forward can also be injected directly into the motor current control algorithm to improve acceleration of high inertia loads.

### MOTION CONTROLLER ALGORITHMS

The Controller makes extensive use of motion controller technology. Profile Generators algorithms take the user position demands and generate a sequence of position and velocity/time values which move the antenna from its present position to the desired position by following a profile which works within the velocity and acceleration limits of the mechanical system. The velocity/time profile provides the reference for the speed loop and the position/time profile provides the position reference for an outer position loop.

For example, to make a step position change, a trapezoidal position profile is calculated. The profile first causes the antenna to accelerate at maximum preset rate to its maximum speed (assuming that sufficient distance is available to do so). The maximum speed is maintained until it is necessary to commence the maximum rate deceleration required to bring the antenna to a halt at the target position. The target is therefore reached in the minimum possible time. Note also that the antenna arrives at the target position with theoretically zero velocity, and so overshoot is minimal.

The role of the position loop in this arrangement is to correct minor pointing departures from the generated profiles and to provide disturbance rejection, primarily that due to wind gusts.

## **EMERGENCY STOP SYSTEM**

The Controller contains a two channel, safety relay. The relay is operated by emergency stop stations in several locations.

- Controller front panel
- Pendant Controller
- Exterior (adjacent to the door)
- On the wheel and track base

The relay's two safety channels are also connected through the elevation backup limit switches and the azimuth key switch (See **BACKUP LIMIT SWITCHES**).

The safety relay needs to be set during system power up, i.e. loss of power causes the relay to trip.

When an emergency stop button is depressed the relay's instantaneous safety contracts open, tripping the drives and causing all axes to perform the quickest possible emergency stop. After a pre-set delay, typically of two seconds, the relay's delayed contacts open causing the drive three-phase contactor to open and remove AC power from the motors.

The external trip method is generally preferred to the enable/disable method as it requires a drive reset to restart the system following an emergency stop.

## **CONTROLLER CLOCK**

The Controller runs a real time clock which it sets and regulates using time data obtained via the Ethernet interface using the SNTP (Simple Network Time Protocol).

A customer supplied SNTP server must therefore be available to the Controller on the local network. The SNTP server can in turn get time using the NTP (Network Time Protocol) for example from a chosen national standard or from a local time standard. A single SNTP server can be used to provide time to a large number of antennas and time requests from an array of Controllers can be staggered in time to avoid network congestion.

The Controller provides status information to indicate failure of the SNTP server to respond; in which case the Controller clock continues to run with the time rate correction determined when the SNTP server was last accessible.

Tests over extended periods have shown the max difference between Controller time and SNTP time in such a system to be less than 20 milliseconds. Latency was a problem in this measurement and it is possible that the true error is significantly less.

The Controller requires the time offset between UT1 and UTC. This value can be obtained from time services and is subject to update at the end of each June and December. Updated values can be input to the Controller via the remote interface.

## **MOTORS**

The elevation and azimuth motors are fully-shielded brushless, AC servomotors.

All motors are fitted with shaft speed encoders. These are high resolution encoders, giving around two million positions per revolution, to give smooth speed control at very low speeds.

All motors are fitted with thermistors which are monitored by the Controller as one means of protecting against damage due to overheating. The drives also run thermal models of the motors to provide early indication of developing problems.

## **BRAKING SYSTEMS**

The two azimuth motors incorporate shaft mounted holding brakes.

Two holding brakes are used in the elevation drive system. One brake is incorporated in the motor, exactly as for azimuth. The second and larger brake is between the elevation motor and the elevation gearbox. Each elevation brake is capable of holding the antenna on its own. It is therefore possible to remove the elevation motor, which includes the motor brake, whilst the antenna is held by the second brake. The two elevation brakes are operated by brake sequencer algorithms running in different processors. The second brake is fitted with a micro-switch which the Controller reads to determine the brake status.

All brakes work in a failsafe mode, so that a brake is applied when the supply is removed.

The Controller monitors the current drawn by each brake to check that the current drawn is within a preset current window. Should the current fall outside this window, the Controller returns to Standby mode and indication of a brake current fault is given in the status information provided via the remote interface. This system helps to prevent the antenna from being driven against a brake, for example in the event blown brake fuse.

## **SOFT LIMITS AND LIMIT SWITCHES**

The first stage of travel range protection is a soft limit system. If an attempt is made to drive either axis beyond a soft limit value, the axis will move only to the soft limit value and not beyond. The antenna can of course be driven out of a soft limit. Note that if a soft limit is reached in one axis while tracking, the other axis continues tracking. Thus for example, if a track is started on a source before it has risen above the antenna's low elevation soft limit angle, the antenna initially tracks in azimuth only and starts to follow the source when the source rises above the soft limit.

The soft limit values are set slightly within the angles at which the limit switches operate, with a deceleration margin to ensure that the antenna can stop between the soft limits and their corresponding limit switches. In normal use it is not possible for the antenna to travel sufficiently far to operate a limit switch. If a limit switch is operated it is possible to reverse out of the limit.

## **BACKUP LIMIT SWITCHES**

A third level of travel range protection is provided for elevation and azimuth.

High and low backup elevation limit switches are mounted so they operate just outside the main limit switches. Thus they can only operate if both the soft limit system and the main limit system fail. These switches are wired as emergency stop buttons so will stop the antenna in all axes.

If the azimuth axes should overrun its soft limits and limit switches, a cord in the azimuth cable wrap tightens and pulls the key out of a key switch. This key switch is wired as an emergency stop button so the antenna stops in all axes.

If either of these backup protection systems operate the antenna requires attention from a suitably qualified engineer to investigate the problem and to drive the antenna back into its normal working range.

## **POSITION READOUT ACCURACY**

The elevation and azimuth angles read from the encoders are available via the remote interface to a precision of 0.0001 degrees. (The Controller also reads position inputs from clients to 4 places of decimals.)

Note the angle displays on drives' keypad displays are only in millidegrees. This is simply because of the limited number of character positions available.

## **CONTROL INTERFACE PHYSICAL DESCRIPTION**

Interface to the Controller is made via multi-mode optical fiber. The fiber is fed through a cut-off waveguide pipe penetration on the bottom face of the Controller and routed to a fiber media converter mounted within the enclosure. The media converter is manufactured by Phoenix Contact, part number FL MC 10/100BASE-T/FO G1300.

## **RFI PRECAUTIONS**

The motor inverter drives and installation are designed to comply with EN61800-3 in the Second Environment.

The above standard is mostly concerned with low frequency EMC. However the Controller incorporates many additional features designed to minimize RFI emissions up to the microwave part of the spectrum, including the following

- Each motor inverter drive is provided with three phase input filter to prevent conducted mains emissions
- Ferrite rings are used on motor power cables
- Fully screened motor power and motor encoder/thermistor cables
- Fully screened axis encoder cables

- RFI Tight Controller enclosure
- Low RFI enclosure ventilation fan
- All penetrations of the Controller enclosure treated appropriately to prevent high frequency radiation from apertures. Techniques include EMC cable glands, cut-off waveguides, and filter connectors, and bulkhead filters
- All mountings to the enclosure walls and door are sealed with electrically conducting paste



# OPERATION

## CONTROLLER STATES

The Controller has several possible states. A ladder approach is used so that a move can only be made to a higher state if certain conditions are met. If the necessary conditions for transition between states on the ladder are no longer met, the Controller reverts to the state immediately below. The Controller state does not automatically resume a higher state when the transition conditions are met again.

The states are as follows.

### SYSTEM POWER OFF

With the system power isolator to the bottom right of the Controller enclosure in the OFF position, the drive system is completely powered-down; the drive software is not running, the motor inverter drives are not powered, and the antenna is held in position by the holding brakes.

Note that a padlock can be placed on the system power isolator to prevent power from being applied, for example when the antenna is withdrawn from service maintenance or repair.

### STANDBY

Closing the system power isolator applies power to the Controller's processors which then start execution of their programs. The Ethernet interface is functional in this state, but only those commands which are valid in STANDBY are executed. The axis encoders are powered and can be read via the remote interface.

Three phase power is not applied to any of the motor inverter drives in this state.

STANDBY is the state that the Controller assumes after an emergency stop has been executed following activation of any of the emergency stop buttons around the antenna.

When STANDBY is entered from the SYSTEM POWER OFF state, the safety relay is open and must be reset by operating the RESET button on the front panel of the Controller or by sending a RESET command to the Controller via the remote interface in order to advance to the next state.

Internally the Controller operates a Run Permit system designed to protect the antenna from damage in certain fault conditions. For example, if an axis runaway has occurred, the Controller is restricted to STANDBY mode.

## OPERATE

Given that the necessary conditions, the Controller can be put into OPERATE state either in LOCAL control by means of the front panel switch, or in REMOTE mode via the remote interface.

In the OPERATE state, three-phase power is applied to the motor inverter drives.

In the absence of a drive trip (both master and slave drives in the case of azimuth) the drives energize and the brakes are released, putting the antenna under closed loop position control.

When the OPERATE state is entered, the RUN Mode is automatically set to STOP which means that the demanded position is set equal to the actual position to prevent any initial antenna movement.

Within the OPERATE state there are five possible RUN Modes.

- STOP – The motion controller generates a profile to take the antenna from its present speed and position to a halt, using a preset deceleration rate.
- POSITION – The motion controller generates a profile to move the antenna from its present speed and position to a given position setpoint, using preset acceleration/decelerations and maximum velocity.
- VELOCITY – The motion controller generates a profile to move the antenna from its present speed and position to a given velocity setpoint, using preset acceleration/decelerations and maximum velocity.
- TRACK – A digital synchronizer causes the antenna to synchronize to a track profile, obtained for example by interpolation of client supplied, time tagged coordinates, or as per the track modes required.
- A newly asked for (by Haystacks) position and velocity mode is also included, under separate document this new feature is described.

The RUN mode can safely be changed at any time, as the Motion Controller generates a profile to make transition between modes whilst remaining within the mechanical limits of the antenna.

Local control from the front panel of the Controller uses only STOP and VELOCITY modes.

## **PROTOCOLS SUPPORTED**

- Web Page http – For simple applications it is possible to control an antenna through its web page. This has the advantage of requiring no client application software, apart from a web browser such as Internet Explorer, Mozilla Firefox, etc. It is not proposed to use the web service as a means of control for the present application, but it is a simple method for viewing and editing parameters and is therefore a useful diagnostic tool.
- Modbus TCP/IP (or Industrial Ethernet) – This is the principle means for controlling and monitoring an antenna in this application, as described later.
- SNTP (Simple Network Time Protocol) - The Controller uses this protocol to obtain time from a server in order to set and regulate its internal clock.
- SMTP (E-mail) – The Controller can be set up to send e-mails to a specified address when defined events occur. E-mails can contain parameter files. This facility is particularly useful for fault reporting and logging.
- FTP – The principle use of this facility here is to update system files.

## **MULTIPLE CLIENT AND SECURITY FEATURES**

Different user categories (e.g. Read Only, General User, and Administrator) have different levels of access to the Controller's interface. Greatest security is provided using the connection filter which allows access only to users with listed IP addresses.

The Controller supports simultaneous, multi-client connections. Up to six clients can be defined as priority clients by including their IP addresses on a priority list. The total number of allowed connections can also be set (up to 26). If the number of clients attempting to connect exceeds the total number of allowed connections, the non-priority client that has communicated least recently is disconnected. Priority clients are never disconnected to make way for others. (In practice it is normally best to have just two or three priority clients, and to limit the total number of connections to somewhat less than the maximum theoretical number.)

## **INTERFACING TO THE CONTROLLER**

Modbus is a widely used master/slave process control protocol. Here Modbus is contained within a TCP/IP wrapper giving Modbus TCP/IP, otherwise known as Industrial Ethernet.

Basically the antenna is controlled by writing values to registers within the Controller. Data and status are obtained by reading registers. All registers used to interface to this Controller function are 32 bit.

Several schemes are available to read and write the Controller's registers from client interface software. One option is to use COTS Modbus TCP/IP controls. These are readily available for Windows™ and Linux operating systems. Another approach is to use an OPC (OLE for Process Control) Automation server such as that supplied with the

Controller. Either way, writing client interface software does not require familiarity with the Modbus TCP/IP protocol.

### **CONTROL VIA THE REMOTE INTERFACE**

The Controller can be set to operate in Equatorial (J2000) or Horizon coordinate mode. Within each mode the following data can be input.

- Position Setpoints
- Velocity Setpoints
- Position Offsets
- Velocity Offsets
- Track Data, each line of data comprising
  - Azimuth/Right Ascension
  - Elevation/Declination
  - Modified Julian Day Number
  - Time of Day

The Controller can store 2000 lines of time tagged track data. Data can be loaded ‘on the fly’, i.e. while in track mode. A form of quadratic interpolation is used between data points.

Principal commands are as follows.

- Power On/Off
- Standby/Operate
- Run Mode = Stop, Position, Velocity, or Track
- Offset Mode = Stop, Position, Velocity
- Enable Pointing Model corrections
- Enable Refractions Correction
- Stow
- Drives Reset
- Controller Reset
- Track Array Flush

Examples of values that can be polled to monitor the activity of an antenna are as follows.

- Encoder Readouts
- Position Errors
- Virtual axis angles (i.e. the demanded angles in track mode)
- Motor Currents
- Controller MJD
- Controller Time

## **STATUS MONITORING**

The Controller makes available several status words which, when decoded bitwise, give status information.

Examples of status bits include the following.

- Local/Remote
- Contactor Off/On
- External Trip
- Drive Healthy
- Drive Energized
- Brake Energized
- Motor temperature warning
- Braking resistor temperature warning
- Brake current level alarm
- Stow in Progress
- Not at Position
- Not at Speed
- Not on Track
- Soft Limits
- Hard Limits
- Position Demand Limited
- Run Permit Error
- Watchdog status
- SNTP server not responding

## **DIAGNOSTICS**

A set of registers are used to contain diagnostic information for use in case of problems. A wide range of information is covered such as trip codes; trip history, motor temperatures, and inverter output stage temperatures are included in the list. A general method is also provided to read the value from any specified register address.

A number of utility programs (for Windows™) are supplied and are useful diagnostic tools. For example a Scope program allows any chosen values (e.g. motor currents, position errors, etc.) to be plotted and stored. An antenna can of course be monitored in this way whilst still in normal service.

## **API FOR REMOTE ROGRAMMING**

An application program interface (API) allows the Controller software to be updated remotely via the Ethernet interface, for example to install updates or add new functions.

### **Antenna Pointing model corrections**

Pointing corrections can be applied to the angles output from the axes encoders to compensate for the pointing errors introduced by misalignments of the azimuth, elevation, and beam axes, and for gravitational deformation of the antenna structure. The coefficients of the pointing model are stored in the inverter drive Application Modules so that corrections can be applied to the received position commands before being passed to the axes position controllers. A nine term pointing model is used to correct for azimuth axis non-verticality, non-orthogonality between axes, and gravitational effects on pointing. The user supplies a demanded angle "on sky" and the Controller automatically applies a correction calculated from its model coefficients. Normally we would expect users would prefer to do their own calibration to determine the model coefficients, although we can help with this if required. There is also a facility for refraction correction. Using pointing model corrections, we expect to achieve a pointing error (for spatial coordinates) of better than 0.005 deg rms, over full sky.

### **Local readout of azimuth and Elevation angles**

Local readout of azimuth and elevation angles is provided on the LCD displays of the inverter drives. Note that these values are corrected for axes misalignments according to the pointing model coefficients stored in the drives.

Local position readout is not a high priority task and is therefore carried out as a background task.

### **Angle Resolvers**

Antenna azimuth and elevation angles are measured using Heidenhain 26 bit encoders. Heidenhain rotary encoders are used extensively in the control industry and there is extensive worldwide support.

### **Lightning protection:**

Finials at the subreflector support apex and reflector rim, plus conductors to the base of the pedestal are used for connection to the customers lightning earthing system.

### **Aircraft warning lights**

Standard high reliability warning lights are fitted to the top edge of the reflector and accordingly are included in this proposal

## **Examples of thorough design employed by Patriot Antenna Systems**

### **Finite Element Analysis Capability**

Patriot Antenna Systems utilizes the latest computer and software tools to ensure an efficient and accurate design process is used. Mechanical design and drawings are produced on AutoCad and SolidWorks using 3D modelling techniques. Designs are analysed and verified on ANSYS analysis software along with a number of in house programs for mechanical and wind load analysis. Our RF expertise is aided by use of the latest in software including HFSS and OSU design software. Patriot's extensive mechanical and RF capability combined with the latest computer tools provide it's customers with both innovative and cost effective solutions.

**Theodolite and photogrammetry** techniques are employed to measure the antenna surfaces.

**Locked Rotor Frequency** is expected to be excess of 2Hz

**Full life, stress analysis and pointing error analysis** can be conducted for a particular application

**Our 12m Antenna design has recently passed the NASA PDR and CDR stages and a CSIRO CDR, and another US customers CDR.**



Examples:  
Wind Pressure Distribution - ANSYS

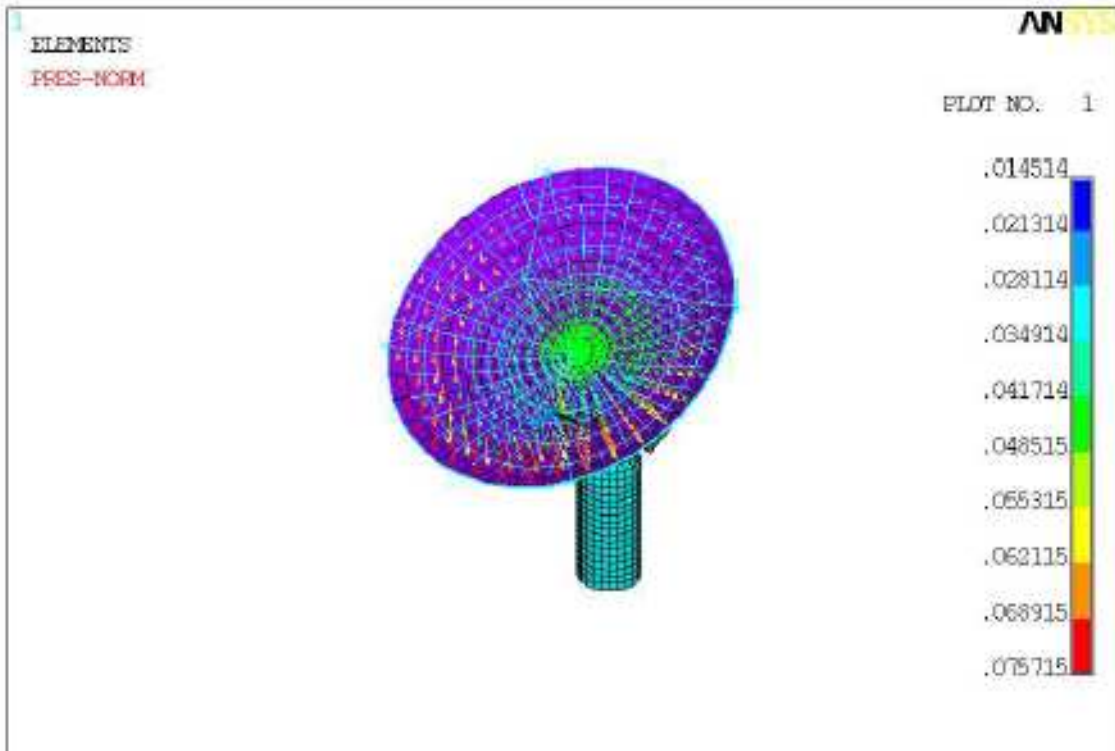

Members Stresses - ANSYS

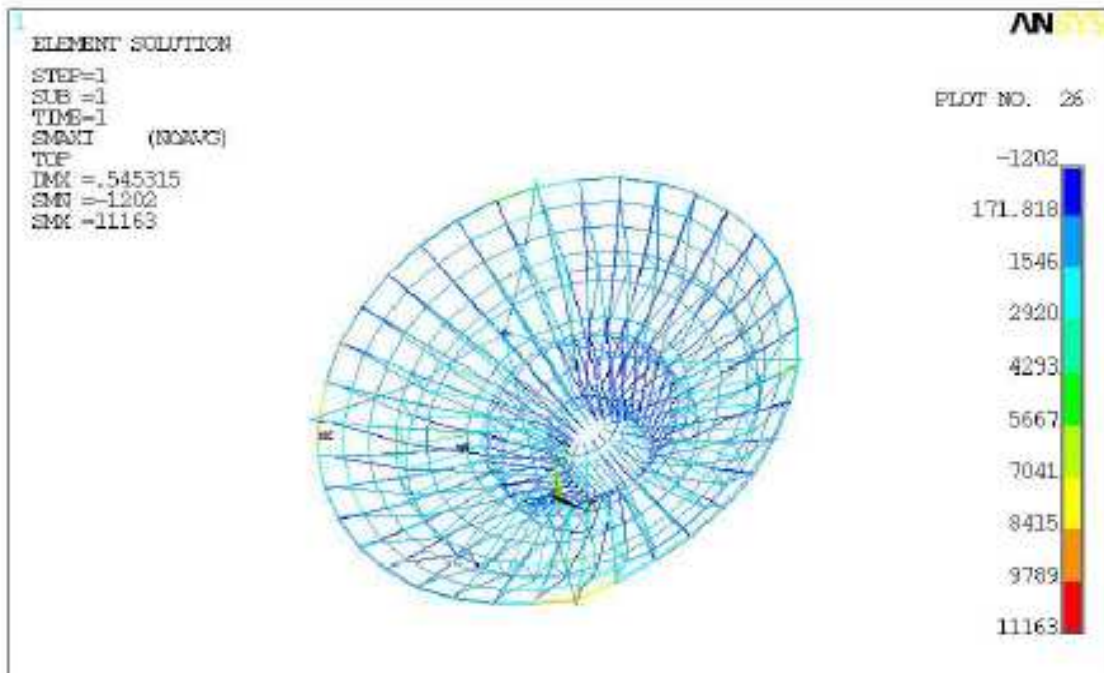

## Typical Laser Tracker and Photogrammetry Surface Measurements

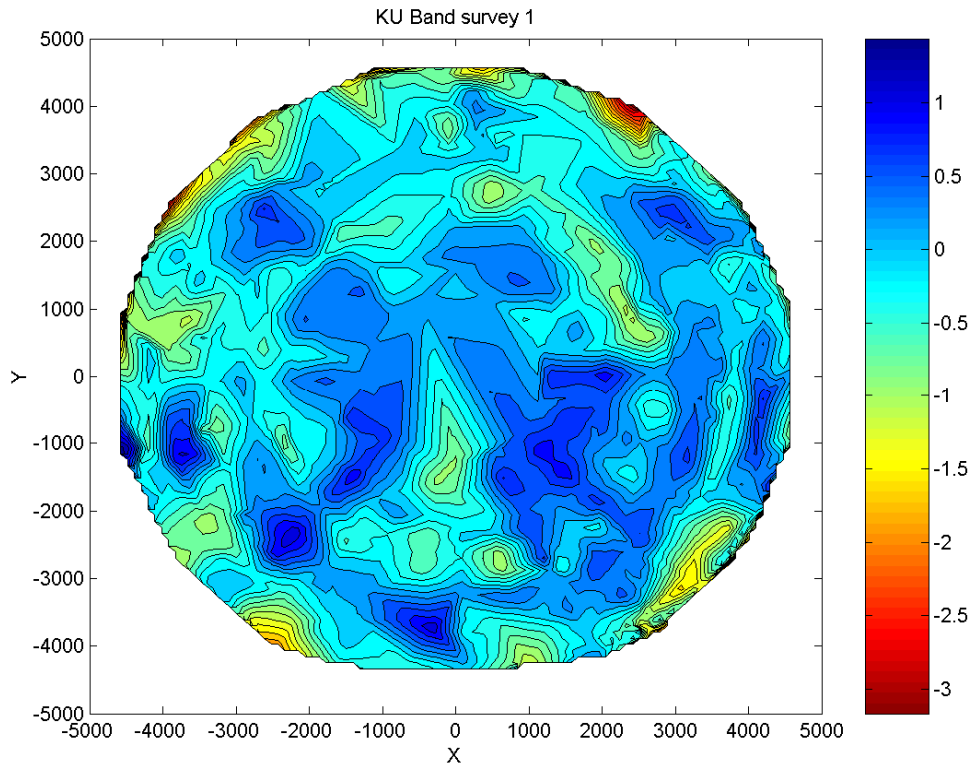

### Documentation

Patriot uses the latest in computer-aided design. A library of previous documentation allows the project engineer to efficiently produce new high quality documentation for each project. In addition Patriot has a complete drafting and design department staffed by expert designers equipped with Solid-works and AutoCAD workstations. All documentation will be prepared in accordance with good commercial practice. Both text and illustrations will be of good quality. Drawings will be fully legible and can be cleanly reproduced. The final handbooks and documentation will be delivered in rugged binders that are suitable for heavy use at the earth station. Patriot Antenna Systems Inc. will supply all Operation and Maintenance documentation required to operate and maintain the antenna system and associated equipment. Documentation will be supplied both electronically and via hard copy (or as required).

### Quality Program

Patriot is committed to the highest quality standards. At Patriot, “prevention” is an underlying concept. The concepts of working to prevent problems, and training people to build the quality into their work, whether it be wiring or engineering, are cornerstones of our philosophy. An Internal Design Review Process is one of the “prevention” processes built into the Project Management Process.

### **Program Management Services**

The primary mission of Patriot is the provision of high quality antenna products. In many cases this includes services and activities well beyond building and delivering an antenna. Most projects involve design, coordination, installation, training and testing that require working closely with the customer for proper planning and implementation. In these cases a Project Manager is assigned and a Project Management Plan developed to guide the activities. The Project Management Plan assures Patriot management and the customer that the program has clearly defined requirements, acceptance criteria, buyer/seller responsibilities, project schedule, budget, cash flow plan and manpower staffing plan. Patriot utilizes computer aided project management tools to assure consistency between all projects and assure all project requirements are properly accounted for. These tools allow management to aggregate all manpower requirements across all of Patriot's current projects and aids in planning future resource needs. All the documents that result from implementing the Program Management Plan (PMP) are computer generated and based on inputs from the Project Manager and the Project Team. The Project Manager is fully responsible for meeting the requirements of the contract, and meeting the customer's expectations. Team members are assigned to the Project Manager and are expected to meet his (or her) expectations as long as they are part of that project team. The Project Manager is assigned resources as required to provide the skills needed to complete the contractual requirements.

### **Spare parts**

A complete set of spare parts for future maintenance and repair of the antenna system are available from Patriot Antennas Systems, Inc. Procedures for installation of replacement parts are detailed in the antenna Operations and Maintenance Manual.

### **Testing**

Patriot Antenna Systems, Inc. will carry out a series of on site acceptance tests to verify that the delivered system meets the performance requirements for this project. Patriot expects to work with their customers to jointly determine an antenna acceptance test plan.

### **Warranty and maintenance**

All equipment supplied shall be warranted for a period of one year following installation and successful testing of the antenna system. A full recommended maintenance schedule is in the operations and maintenance manual supplied with the antenna. Maintenance services can be provided if requested.

## **Maintainability**

All Patriots larger antennas are designed to allow very quick and easy access to the maintenance locations on the antenna as can be seen from the drawing on page 47. The electronic drives are readily accessible for routine maintenance and inspection. Location of the motors and brakes also provides for easy access and maintenance. The drives routinely monitor the motor temperatures to so as to look out for and report a potential problem.

The azimuth bearing grease fittings are located on the inside of the bearing race and are accessed from the upper platform located inside the pedestal tube.

Even the main elevation jack drive or motor can be changed out easily if ever required after an extremely extended period (although life testing predicts a 20+ year life).

Assuming correctly performed routine maintenance we see no reason why the service life of these antennas should not easily exceed 30 years. The main potential wear out parts motors and the elevation jack are extremely easy and low cost to replace compared to the older style of antenna designs. A detailed set of routine mechanical maintenance requirements extracted from our full Operation and maintenance manual are shown below.

## **VISUAL INSPECTION**

Visually inspect all structural and mechanical components for signs of damage and/or wear. Check hardware for tightness and general condition. Visually inspect paint for sign of weather damage or peeling and repair as required.

## **PEDESTAL DOOR HINGES**

Inspect pedestal door hinge and latch for proper operation. Apply spray lubricant to each hinge on the pedestal door. Remove any excess.

## **AZIMUTH BEARING**

Visually inspect bearing seal for signs of damage or excessive leaking. Lubricate the azimuth bearing via the two grease nipples located at the inner raceway. Access to the lubrication points is from the platform inside the pedestal at the azimuth cable wrap area. Lubricate with 10 shots of grease at each fitting per the maintenance table frequency page 17. When the antenna is returned to service rotate the antenna +/- 180° in order to spread new lubrication throughout the bearing.

## **AZIMUTH GEAR AND PINION**

Check azimuth gear teeth and pinions for obvious signs of damage or wear. Lubricate gear and pinion teeth liberally with a heavy duty gear tooth lubricant grease. Make sure all exposed surfaces of the gear and pinion are lubricated as this also acts as the corrosion prevention for these components.

## **AZIMUTH GEARBOX**

Visually inspect for signs of leaks or damaged seals. Remove oil fill plug and check oil level in gearbox. If low add oil to appropriate level and replace fill plug. Inspect oil drawn when level is checked for any signs of metal or overheating. If necessary drain gearbox and refill with new oil.

## **ELEVATION SCREW JACK**

Inspect the elevation actuator bellows for damage and wear. If bellows integrity is compromised replace with new one. Loosen clamp at bottom of bellows and pull bellows back to expose the actuator screw. Inspect screw for damage and/or wear. Apply a liberal amount of grease to the screw. Replace bellows and clamp after inspection and lubrication of the screw. Grease the actuator with 10 shots from hand held grease gun at each lubrication fitting.

## **ELEVATION GEARBOX**

Visually inspect for signs of leaks or damaged seals. Remove oil fill plug and check oil level in gearbox. If low add oil to appropriate level and replace fill plug. Inspect oil drawn when level is checked for any signs of metal or overheating. If necessary drain gearbox and refill with new oil.

## **ELEVATION JACK TRUNNION AND JACK PIN**

Lubricate the 2 elevation trunion pins found at the jack mounting inside of the turning head with 4 shots of grease at each fitting. Lubricate the jack pin via the lubrication fitting found on the jack rod end at the hub connection with 4 shots of grease.

## **ELEVATION AXIS BEARINGS**

Inspect elevation bearing seals for signs of damage or excessive leaking. Lubricate each elevation axis bearing at the lubrication fitting found on the elevation axis lug found on the turning head. Apply 4 shots of grease at each fitting.

## **ELECTRICAL SYSTEMS CHECK**

Check all wiring, conduit and connections for proper installation and integrity. Check cable wraps and axis cross over for proper operation and strain relief. Repair any damage and defects prior to returning antenna to service.

## **CORROSION PROTECTION AND CONTROL**

Visually inspect the painted structure for damage or signs of corrosion. Where required, wire brush the affected area to remove dirt, corrosion and loose paint. Apply 1 coat of a good quality primer followed by 2 coats of white paint.

## REFLECTOR SURFACE

Visually inspect the reflective surface for signs of excessive dirt, damage and/or weathered paint. Clean surfaces using warm soapy water as required. For damaged surfaces light sand the selected area, taking care not to damage reflective surface, and repaint with 1 coat of primer and 1 coat of white paint.

## Typical mechanical maintenance schedule:

### MAINTENANCE RECORD TABLE

Lube Point #	Description	Frequency Months			Type of Service	Type of Lube	No. of Lube Points	Quantity
		3	6	12				
1	Pedestal Door Hinges			X	Spray Lube	grease	2	
2	Azimuth Bearing		X		Pressure Fitting	grease***	2	10 shots
3	Azimuth Gear and Pinions		X			grease**	outer surfaces	
4	Azimuth and Elevation Geardrives	I****	C****		Pipe Plugs	SHC624		
5	Elevation Jack Housing		X		Pressure Fitting	grease*	2	10 shots
6	Elevation Jack Screw		X			grease*	outer surface	
7	Elevation Jack Trunnion Pins		X		Pressure Fitting	grease*	2	4 shots
8	Elevation Jack Clevis Pin		X		Pressure Fitting	grease*	1	4 shots
9	Elevation Axis Bearings		X		Pressure Fitting	grease*	2	4 shots

X = Lubricate I = Inspect C = Change

\* Grease- Use Mobil 1 synthetic

\*\* Grease- Grafloscon

\*\*\* Grease- Molycote #33

\*\*\*\* Inspection requires checking for visible signs of oil leakage, draining replacing and adding oil to ensure appropriate oil level requirements. Excessively dirty oil will require fresh oil replacement. If oil leakage is found to be excessive perform applicable corrective action. Periodic inspection procedures can be less frequent after first or second scheduled inspections.



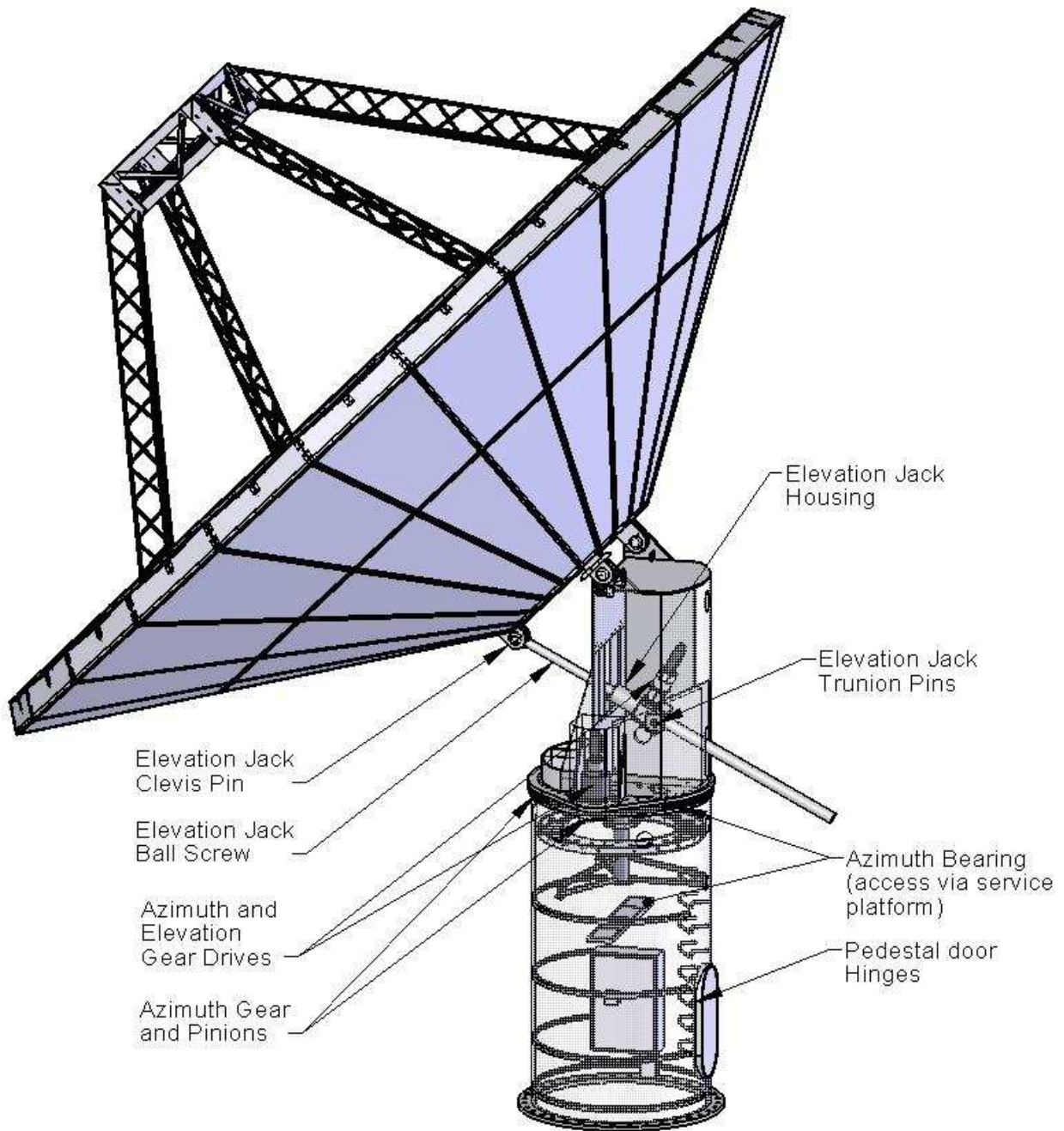

A full set of instructions for detailed maintenance involving the full but simple procedures needed to change all the major components are available.



**Recommended 12m antenna system spare parts list**

Ref. Sales Order(s):					
Customers: (Standard 12m)					
Job Order(s):					
<b>12m SPARE PARTS KIT</b>					
<b>Patriot Part No.</b>	<b>Description</b>	<b>Manufacture/ Part No.</b>	<b>Lead time (wks)</b>	<b>Qty. per Kit</b>	<b>Vendor / Supplier</b>
4EM0061	ENCODER, 12m AZ & EL	Heidenhain Model ROC 226 (see spec's)	10	1	Heidenhain Corp.
4EM0064	CLUTCH BRAKE	Lenze #BFK458-12N, 24VDC, 25mm bore	3	1	BRAKECLUTCH, LLC
4EM0065	LIMIT SWITCH, TOP ROLLER (1NC/1NO)	Honeywell #GLAA01C (inch)	3	1	Honeywell
4EM0066	LIMIT SWITCH, TOP ROLLER (2NC/2NO)	Honeywell #GLAA20C (inch)	3	1	Honeywell
4EM0099	MTR, 12m AZIM SERVO-CONT TECHNIQUES	Control Techniques #142U2D301VASAB165240	6	1	Control Techniques UK
4EM0100	MTR, 12m ELEV SERVO-CONT TECHNIQUES	Control Techniques #142U2D401VASAB165240	6	1	Control Techniques UK
4EM0102	DRIVE, 12m SERVO MTR ELECTRONIC	Control Techniques #SP1406	2	1	Control Techniques UK
4M00162	BOOT, 12m ELEVATION JACK	Joyce-Dayton #09050056	2	1	Joyce-Dayton, Inc.

Some of Patriots Antenna systems facilities



**Patriot advanced manufacturing facilities for large antenna components**

Stretch forming



Laser cutting



Water jet cutter





**Patriot's 9.4m Antenna with hot air de-ice system on customers pedestal.**

**Patriot's 12m Antenna and pedestal showing some of the unique maintenance features**



Easily accessible motors and gearboxes

In pedestal electronics

Easily replaceable jack system, no crane required

**Completed 12m antenna at Patriot, for the DSN Array**





**12m antenna rear view**



**One complete Patriot 12m antenna being loaded into two shipping containers for sea transport**







## Patriot Antenna Systems

### FFP Price proposal

12.1m antenna system.

Description	Price each in \$ USD
12.1m antenna system suitable for primary use from 1.5 GHz to 17GHz, 5 Deg/ sec in Azimuth and 1.25 Deg/ sec av. in elevation	\$548,000
Optional S/ X band dual polarization CP twin band, 4 output feed	\$65,000
Optional S and X band LNAs (4 total)	\$21,500
Optional loop coupler set plus one X band WG bend	\$7,400
Optional waveguide dehydrator inlet ports, one X band and one S band	\$1,070
Optional external access ladder	\$2,000
Optional set of spare parts as suggested on page 51	\$21,712
<b>Total (with all options)</b>	<b>\$666,682</b>

All the above prices are FOB Albion Mi.

Patriot price for installation (Excluding civil works and machinery rental): An additional **\$57, 211 plus approved Travel and living expenses to Puerto Rica for our installation team**. Assumes some local staff (technicians and labour) are available to help and the concrete foundation is provided in accordance with Patriot supplied information.

Price for sea transportation, insurance etc to site is estimated at **\$22,000** per antenna. Antenna ships in 2 standard HC 40ft shipping containers.

**Proposed payment Milestones (Based on all quoted options included)**

<b>PATRIOT ANTENNAS SYSTEMS MILESTONE SCHEDULE</b>			
<b>Event</b>	<b>Milestone Date</b>	<b>Milestone %</b>	<b>Milestone \$</b>
Start Up Review/KO	½ MARO	25	\$166,670.50
Ship Antenna to Site	TBC	65	\$433,343.30
Installation/Test/Full Commissioning and sign off including commissioning and delivery	4-5 MARO TBC	Last 10% of antenna plus commissioning and delivery	\$145,879.20
		100	\$745,893

Installation could commence in Feb/Mar 2010, if ordered in Nov 09, i.e. 4-5 months ARO.

Payment terms net 30 days, payment milestones as above.

The above proposed prices are valid for 60 days from the date on page 1

**Summary:**

We hope that the above is sufficient to demonstrate Patriot Antenna Systems competitive capabilities and we look forward supplying one of these antenna systems.

Yours sincerely

*Peter Shield*

For Patriot Antenna Systems

**Proprietary notice**  
 The data and prices contained within this document are the proprietary data of Cobham SATCOM, Land Systems, Patriot Products Inc. Neither the document nor the information contained within shall be used, reproduced, or disclosed to others without the written authorization of Cobham SATCOM, Land Systems, Patriot Products Inc.